

CURRICULUM-2023
(C-23)

**DIPLOMA IN ELECTRONICS &
COMMUNICATION
ENGINEERING**

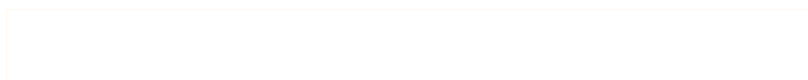

1. PREAMBLE

The world is constantly evolving, and so must our approach to education. Our curriculum has been designed with this in mind, with a focus on practical skills, critical thinking, and problem-solving. We believe that these skills are essential for success in both academic and professional spheres.

At the heart of our curriculum is the belief that education should be student-centered, empowering learners to take ownership of their learning and pursue their passions. We aim to create a learning environment that is safe, supportive, and nurturing, where every student has the opportunity to reach his/her full potential. We acknowledge that learning is a lifelong journey, and our curriculum is designed to provide a solid foundation for continued growth and development. We hope that our students will not only leave with a diploma but with employability and passion for learning

The State Board of Technical Education and Training, (SBTET) AP, has been offering Diploma programmes to meet the above said aspirations of the stake holders: students, parents, industries, academia, and the society at large. As such, it has been the practice of SBTET, A.P., to keep the curriculum abreast with the advances in technology through systematic and scientific analysis of current curriculum and bring out an updated revised version at regular intervals. Accordingly the SBTET, AP under the aegis of the Department of Technical Education, Andhra Pradesh in its **57th** Board Meeting held on **05-02-2019** (vide item no: **18**) resolved to update the Polytechnic Curriculum C-20, to be implemented with effect from the academic year 2023-24.

Analysis of Curriculum C-20 was started in the month of January-2023. Feedback was collected from all stakeholders: Students, Lecturers, Senior Lecturers, Heads of Sections and Principals for all programmes for this purpose.

A Meeting was convened on 15th February 2023, from 10:00 A.M. onwards, by Smt. C. Naga Rani, I.A.S, Director of Technical Education & Chairperson, SBTET to discuss on revamping of C-20 curriculum to meet the needs of industries and for improvement of placements.

The meeting was attended by Sri Saurab Gaur, I.A.S, Principal Secretary, Skill Development & Training, Smt. Lavanya Veni, I.A.S, Director, Employment & Training. Thirteen Representatives from Industries and 14 Academicians from Higher level institutions and Officials of ITI, Skill Development, CTE and BTET attended the workshop.

Smt. C Naga Rani, I.A.S., Commissioner of Technical Education while addressing in the workshop, the necessity of industrial training and on hand experience, emphasised that the students need to undergo to support the industries. The gaps in the Curriculum need to be fixed to make the students passionate to work in the industry in order to support economy of the country.

The committees of each branch constituted with experts from industry, higher level Institutions and faculty of Polytechnics are informed to study the possibility of incorporating the following while preparing the curriculum so as to improve employability.

- IOT for all branches
- Theoretical & Practical subjects 50 : 50 Ratio
- Industry 4.0 concepts



- 5G Technology
- Critical Thinking (Quantitative Aptitude, Data Interpretation, Quantitative reasoning etc) to face the written tests conducted by the industries during placements.
- Internships after 1st Year, 3rd Sem (2 to 3 weeks)

A series of workshops with subject experts followed in the subsequent weeks for thorough perusal and critique of draft curricula; and the suggestions thus received from Industrialists and academia have been recorded, validated by another set of experienced subject teachers from the Department of Technical education for incorporation into the Curriculum C-23.

Finally, the draft curriculum was sent to academicians of higher-level institutions, industrial experts and NITTTR (ECV) for wetting.

The design of new Curricula for the different diploma programmes has thus been finalised with the active participation of the members of the faculty teaching in the Polytechnics of Andhra Pradesh, and duly reviewed by Expert Committee constituted of academicians and representatives from industries. Thus, the primary objective of the curriculum change is to produce employable diploma holders in the country by correlating the growing needs of the industries with relevant academic input.

The outcome-based approach as given by NBA guidelines has been followed throughout the designing of this curriculum to meet the requirements of NBA Accreditation, too.

The revised New Curriculum i.e., Curriculum–2023 (C-23) is approved by Board of Governors of SBTET for its implementation with effect from the academic year 2023-24.

2. HIGHLIGHTS OF CURRICULUM C-23

1. Duration of course for regular Diploma is 3 years.
2. The Curriculum is prepared in Semester Pattern. However, First Year is maintained as Year-wise pattern.
3. 6 Months Industrial training has been introduced for 3 years Diploma Courses in VI semester.
4. Updated subjects/topics relevant to the industry are introduced in all courses at appropriate places.
5. The policy decisions taken at the State and Central level with regard to environmental science are implemented by including relevant topics in Chemistry. This is also in accordance with the Supreme Court guidelines issued in Sri Mehta's case.
6. Keeping in view the increased need of communication skills which is playing a major role in the success of Diploma Level students in the industries, emphasis is given for learning and acquiring listening, speaking, reading and writing skills in English. Further as emphasized in the meetings, Communication Skills lab and Life Skills lab are continuing for all the branches.
7. Upon reviewing the existing C-20 curriculum, it is found that the theory content is found to have more weightage than the Practical content. In C-23 curriculum, more emphasis is given to the practical content in Laboratories and Workshops, thus strengthening the practical skills. The ratio of Theory & Practicals is 50:50.

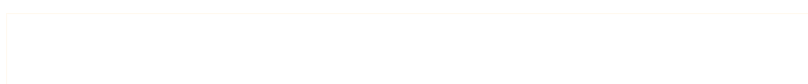

8. With increased emphasis for the student to acquire Practical skills, the course content in all the subjects is thoroughly reviewed and structured as outcome based than the conventional procedure based.
9. Curriculum of Laboratory and Workshops have been thoroughly revised based on the suggestions received from the industry and faculty, for better utilization of the equipment available in the Polytechnics. The experiments /exercises that are chosen for the practical sessions are identified to confirm to the field requirements of industry.
10. The theory and practical subjects are restructured to find room for new theory and practical subjects to meet the present the industrial needs.
11. To make the students effective and efficient in all aspects, three periods per week are allotted in every year/semester for STUDENT CENTRIC ACTIVITY in which student will be trained for placements or make use of library or participate in sports & games/clean & green etc.

The following specific changes are discussed and incorporated in C-23 Curriculum:

- i) The course on 8086 Microprocessor (C-20) is found obsolete and hence removed
- ii) A new practical course on Electrical Engineering Lab (EC-112) is introduced
- iii) A new theory course on IoT and Sensors (EC-404) is introduced
- iv) A new theory course on Digital Logic Design using Verilog HDL (EC-405) is introduced
- v) A new practical course on IoT and Sensors Lab (EC-409) is introduced
- vi) A new practical course on Digital Logic Design Lab using Verilog HDL (EC-410) is introduced
- vii) A new theory course on Embedded Systems (EC-502) is introduced
- viii) A new practical course on Embedded Systems Lab (EC-506) is introduced
- ix) The course on Electronic Measurements and Consumer Gadgets is removed. Some topics from this course are added in other appropriate courses.
- x) In the course, Optical and Mobile Communications (EC-503), some obsolete topics on telephony are removed and new topics on 5G technologies are added.
- xi) In the course, Elements of Electrical Engineering (EC-106), some topics on Batteries were added.
- xii) The course on Industrial Electronics (C-20) is renamed as Industrial Electronics and Automation (EC-504) and some topics on PLC & SCADA are added.
- xiii) The course on Computer Hardware & Networking (C-20) is renamed as Data Communication & Computer Networking (EC-505). Some topics on Computer Hardware topics were removed and topics on Wireless technologies and Network Security are added in the course.
- xiv) The course on Industrial Management & Smart Technologies (C-20) is renamed as Industrial Management & Entrepreneurship (EC-501). Topics on Smart Technologies is removed and new topics on Industrial Safety are added in this course.

3. ACKNOWLEDGEMENTS

The Members of the working group are grateful to Smt C. Naga Rani I.A.S., Commissioner of Technical Education & Chairman of SBTET, and Sri. Saurab Gaur,I.A.S, Principal Secretary, Skill

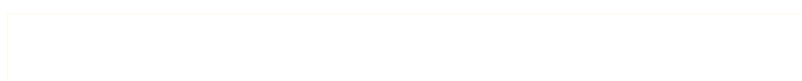

Development & Training for their guidance and valuable inputs during process of revising, modifying and updating the Curriculum C-20 to Curriculum C-23.

It is pertinent to acknowledge the support of the following in the making of Curriculum C-23. A series of workshops in different phases were conducted by SBTET, AP, Mangalagiri involving faculty from Polytechnics, Premier Engineering Colleges (List of Colleges) & Industries (List of Industries) to analyse the Previous C-20 Curriculum and to design C-23 Curriculum is highly appreciated and gratefully acknowledged.

The invaluable contribution of Sri K. Vijaya Bhaskar, Secretary, SBTET, Andhra Pradesh, Sri V. Padma Rao, Joint Director of Technical Education, officials of Directorate of Technical Education and the State Board of Technical Education, Andhra Pradesh and all teaching fraternity from the Polytechnics who are directly or indirectly involved in preparation of the curriculum C-23 are much appreciable and indebted.

4. RULES AND REGULATIONS OF C-23 CURRICULUM

4.1 Duration and pattern of the courses

All the Diploma programs run at various institutions are of AICTE approved 3 years or 3½ years duration of academic instruction. All the Diploma courses are run on year wise pattern in the first year, and the remaining two or two & half years are run in the semester pattern. In respect of few courses like Diploma in Bio-Medical course, the training will be in the seventh semester. Run-through system is adopted for all the Diploma Courses, subject to eligibility conditions.

4.2 Procedure for Admission into the Diploma Courses:

Selection of candidates is governed by the Rules and Regulations laid down in this regard from time to time.

- a. Candidates who wish to seek admission in any of the Diploma courses will have to appear for the Common Entrance Test for admissions into Polytechnics (POLYCET) conducted by the State Board of Technical Education and Training, Andhra Pradesh, Mangalagiri. Only the candidates satisfying the following requirements will be eligible to appear for the Common Entrance Test for admissions into Polytechnics (POLYCET).
- b. The candidates seeking admission should have appeared for S.S.C examination, conducted by the Board of Secondary Education, Andhra Pradesh or equivalent examination thereto, at the time of applying for the Common Entrance Test for admissions into Polytechnics (POLYCET). In case of candidates whose results of their Qualifying Examinations is pending, their selection shall be subject to production of proof of their passing the qualifying examination in one attempt or compartmentally at the time of admission.
- c. Admissions are made based on the merit obtained in the Common Entrance Test (POLYCET) and the reservation rules stipulated by the Government of Andhra Pradesh from time to time.

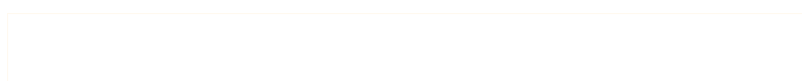

- d. For admission into the following Diploma Courses for which entry qualification is 10+2, candidates need not appear for POLYCET. A separate notification will be issued for admission into these courses.

i) D.HMCT ii) D. Pharmacy

4.3 Medium of Instruction

The medium of instruction and examination shall be in English.

4.4 Permanent Identification Number (PIN)

A cumulative / academic record is to be maintained of the Marks secured in sessional work and end examination of each year for determining the eligibility for promotion etc., A Permanent Identification Number (PIN) will be allotted to each admitted candidate to maintain academic records.

4.5 Number of Working Days per Semester / Year:

- a) The Academic year for all the Courses shall be in accordance with the Academic Calendar.
- b) The Working days in a week shall be from Monday to Saturday
- c) There shall be 7 periods of 50 minutes duration each on all working days.
- d) The minimum number of working days for each semester / year shall be 90 / 180 days excluding examination days. If this prescribed minimum is not achieved due to any reason, special arrangements shall be made to conduct classes to complete the syllabus.

6 Eligibility (Attendance to Appear for the End Examination)

- a) A candidate shall be permitted to appear for the end examination in all subjects, if he or she has attended a minimum of 75% of working days during the year/Semester.
- b) Condonation of shortage of attendance in aggregate up to 10% (65% and above and below 75%) in each semester or 1st year may be granted on medical grounds.
- c) A stipulated fee shall be payable towards condonation for shortage of attendance.
- d) Candidates having less than 65% attendance shall be detained.
- e) Students whose shortage of attendance is not condoned in any semester / year and not paid the condonation fee in time are not eligible to take their end examination of that class and their admissions shall stand cancelled. They may seek re-admission for that semester / year when offered in the next subsequent academic semester/year.
- f) For INDUSTRIAL TRAINING:
 - i) During Industrial Training the candidate shall put in a minimum of 90% attendance.
 - ii) If the student fails to secure 90% attendance during industrial training, the student shall reappear for 6 months industrial training at his own expenses.



4.7 Readmission

Readmission shall be granted to eligible candidates by the respective Principal/ Regional Joint Director.

- a) (i) Within 15 days after commencement of class work in any semester (Except Industrial Training).
- (ii) For Industrial Training: before commencement of the Industrial training.
- b) Within 30 days after commencement of class work in any year (including D. Pharmacy course or first year course in Engineering and Non-Engineering Diploma streams). Otherwise, such cases shall not be considered for readmission for that semester / year and are advised to seek readmission in the next subsequent eligible academic year.
- c) The percentage of attendance of the readmitted candidates shall be calculated from the first day of beginning of the regular class work for that year / Semester, as officially announced by CTE/SBTET but not from the day on which he/she has actually reported to the class work.

4.8 Scheme of Evaluation

a) First Year

Theory Courses: Each Course carries Maximum marks of 80 with examination of 3 hours duration, along with internal assessment for Maximum of 20 marks. (Sessional marks). However, there are no minimum marks prescribed for sessionals.

Laboratory Courses: There shall be 40 Marks for internal assessment i.e. sessional marks for each practical Course with an end examination of 3 hours duration carrying 60 marks. However, there are no minimum marks prescribed for sessionals.

b) III, IV, V, VI and VII Semesters:

Theory Courses: End semester evaluation shall be of 3 hours duration and for a maximum of 80 marks.

Laboratory Courses: Each Course carry 60/30 marks of 3 hours duration 40/20 sessional marks.

4.9 Internal Assessment Scheme

- a) **Theory Courses:** Internal assessment shall be conducted for awarding Sessional marks on the dates specified. **Three-unit tests shall be conducted for I year students and two Unit Tests for semesters.**

Internal Assessment shall be of 90 minutes duration and for a maximum of 40 marks for each test.

S. No.	Type of Assessment	Weightage Assigned

--

(i)	Testing of knowledge through mid-examination for year/sem as (Mid-1+Mid-2+Mid3) or (Mid-1 + Mid-2)	40
(ii)	Assignments	05
(iii)	Dynamic Learning activities : Project Work/ Seminar/Tech-fest/Group Discussion, Quizzes etc./Extra-curricular activities/NSS/NCC/ IPSGM/Cleaning & Greening of Campus etc.	05
TOTAL		50

At least one assignment should be completed for each unit which carries 10 marks. The total assignment marks should be reduced to 5.

At least one dynamic learning activity is to be conducted which carries 10 marks. The total marks should be reduced to 5.

The total 50 marks assigned to internal assignment is to be scaled down to 20 marks.

b) Practical Courses:

(i) Drawing Courses:

The award of Sessional marks for internal Assessment shall be as given in the following table:

Distribution of Marks for the Internal Assessment Marks			
First Year (Total:40 Marks)		Semesters (Total:40 Marks)	
Max:20 Marks	Max:20 Marks	Max:20 Marks	Max:20 Marks
From the Average of THREE Unit Tests.	From the Average of Assessment of Regular Class work Exercises.	From the Average of TWO Unit Tests.	From the Average of Assessment of Regular Class work Exercises.

- For first year engineering drawing each unit test will be conducted for a duration of 2 hours with maximum marks of 40.
- (Part - A : 4 questions x 5 marks = 20 Marks ; Part –B: 2 questions x 10 marks = 20 marks).
- For the semester drawing examinations, Two Unit tests shall be conducted as per the Board End Examination Question Paper Pattern.
- All Drawing exercises are to be filed in serial order and secured for further scrutiny by a competent authority

(ii) Laboratory Courses:

- (a) Student's performance in Laboratories / Workshop shall be assessed during the year/ semester of study for 40 marks in each practical Course.

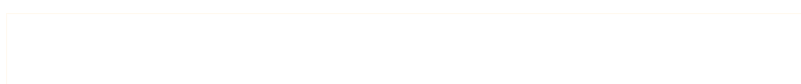

(b) Evaluation for Laboratory Courses, other than Drawing courses:

- i. Instruction (teaching) in laboratory courses (except for the course on Drawing) here after shall be task/competency based as delineated in the Laboratory sheets, prepared by SBTET, AP & NITTTR- ECV and posted in SBTET website.
 - ii. Internal assessment for Laboratory shall be done on the basis of task/s performed by the student as delineated in the laboratory sheets, prepared by SBTET, AP & NITTTR- ECV and posted in AP, SBTET website.
 - iii. Question paper for End semester Evaluation shall also be task/s based and shall be prepared and distributed by SBTET as done in case of theory courses be prepared as per SBTET rules in vogue.
- c) Internal assessment in Labs / workshops / Survey field work etc., during the course of study shall be done and sessional marks shall be awarded by the concerned Teacher.
- d) For practical examinations, except in drawing, there shall be two examiners. External examiner shall be appointed by the Principal in consultation with respective Head of Section, preferably choosing a qualified person from in the order of preference.
- i) Nearby Industry
 - ii) Govt / Semi Govt organization like R & B, PWD, PR, Railways, BSNL, APSRTC, APSEB etc.
 - iii) Govt / University Engg College.
 - iv) HoDs /Senior Lecturer/ Lecturer from Govt. Polytechnic
- Internal examiner shall be the person concerned with internal assessment as in (c) above. The end examination shall be held along with all theory papers in respect of drawing.
- e) Question Paper for Practicals: Question paper should cover (the experiments / exercise prescribed to test various) skills like handling, manipulating, testing, trouble shooting, repair, assembling and dismantling etc., from more than one experiment / exercise
- f) Records pertaining to internal assessment marks of both theory and practical Courses are to be maintained for official inspection.
- g) In case of Diploma programs having Industrial Training, Internal Assessment and Summative Evaluation, shall be done as illustrated in the following table:

Assessment No	Upon completion of	By	Based on	Max Marks
1	12 weeks	1.The faculty concerned (Guide) and 2. Training in charge (Mentor) of the industry	Learning outcomes as given in the scheme of assessment ,for Industrial Training	120
2	22 weeks			120
3.Final summative	24 week	1.The faculty member concerned,	1.Demonstration of any one of the skills listed in learning	30



Evaluation		2.HoD concerned and 3.An external examiner	outcomes	
			2.Training Report	20
			3.Viva Voce	10
TOTAL				300

h) Each staff member including Head of Section shall be assigned a batch of students 10 to 15 for making assessment during industrial training.

Add Industrial Training Policy Guidelines

GUIDELINES FOR INDUSTRIAL TRAINING OF DIPLOMA IN ELECTRICAL AND ELECTRONICS ENGINEERING PROGRAMME:

1. Duration of the training: 6 months (24 weeks).
2. Eligibility: As per SBTET norms
3. Training Area: Students can be trained in the relevant industries or companies etc., related to Electronics & Communication Engineering fields.
4. The Industrial Training shall carry 300 marks and pass marks is 50% in assessment at industry (first and second assessment put together) and also 50% in final summative assessment at institution level.
5. Formative assessment at industry level shall be carried out by the representative of the industry, where the student is undergoing training and the faculty from the concerned section in the institution.
6. If the student fails to secure 50% marks in industrial assessments put together, the student should reappear for 6 months industrial training at his/her own expenses.
7. If the student fails to secure 50% marks in final summative assessment at institution level, the student should reappear for final summative assessment in the subsequent board examination.
8. Final Summative assessment at institution level is done by a committee including **1. Head of the section (of concerned discipline ONLY), 2. External examiner from an industry and 3. Faculty member who assessed he student during industrial training as member.**
9. During Industrial Training the candidate shall put a minimum of 90% attendance.
10. If the student fails to secure 90% attendance during industrial training, the student should reappear for 6 months industrial training at his/her own expenses.

4.10 Minimum Pass Marks

a) Theory Examination:

For passing a theory Course, a candidate has to secure a minimum of 35% in end examination and a combined minimum of 35% of both Sessional and end examination marks put together.

b) Practical Examination:

For passing a practical Course, a candidate has to secure a minimum of 50% in end examination and a combined minimum of 50% of both sessional and practical end examination marks put together. In case of D.C.C.P., the pass mark for Typewriting and Shorthand is 45% in the end examination. There are no sessional marks for typewriting and Shorthand Courses of D.C.C.P course.

C) Industrial Training:

- I. Monitoring: Similar to project work each teacher may be assigned a batch of 10-15 students irrespective of the placement of the students to facilitate effective monitoring of students learning during industrial training.
- II. Assessment: The Industrial training shall carry 300 marks and pass marks is 50% in assessments at industry (first and second assessment) and final summative assessment at institution level put together i.e. 150 marks out of 300 marks. And also student has to secure 50% marks in final summative assessment at institution level.

4.11. Provision for Improvement

Improvement is allowed only after he / she has completed all the courses from First Year to Final semester of the Diploma.

- a) Improvement is allowed in any 4 (Four) Courses of the Diploma.
- b) The student can avail of this improvement chance **ONLY ONCE**, that too within the succeeding two examinations after the completion of Diploma. However, the duration including Improvement examination shall not exceed **FIVE** years from the year of first admission.
- c) No improvement is allowed in Practical / Lab Courses or Project work or Industrial Training assessment. However, improvement in drawing Course(s) is allowed.
- d) If improvement is not achieved, the marks obtained in the previous Examinations hold good.
- e) Improvement is not allowed in respect of the candidates who are punished under Mal-practice in any Examination.
- f) Examination fee for improvement shall be paid as per the notification issued by State Board of Technical Education and Training from time to time.
- g) All the candidates who wish to appear for improvement of performance shall deposit the original Marks Memos of all the years / Semesters and also original Diploma Certificate to the Board. If there is improvement in performance of the current examination, the revised Memorandum of marks and Original Diploma Certificate will be issued, else the submitted originals will be returned.

4.12. Rules of Promotion From 1ST YEAR TO 3rd, 4th, 5th, 6th and 7th Semesters:

A) For Diploma Courses of 3 Years duration



- i. A candidate shall be permitted to appear for first year examination provided he / she puts in 75% attendance (which can be condoned on Medical grounds up to 10%) i.e. attendance after condonation on Medical grounds should not be less than 65% and pay the examination fee.
- ii. A candidate shall be promoted to 3rd semester if he/she puts the required percentage of attendance in the first year and pays the examination fee. A candidate who could not pay the first year examination fee has to pay the promotion fee as prescribed by State Board of Technical Education and Training, AP from time to time before commencement of 3rd semester.
- iii. A candidate shall be promoted to 4th semester provided he/she puts the required percentage of attendance in the 3rd semester and pay the examination fee. A candidate, who could not pay the 3rd semester exam fee, has to pay the promotion fee as prescribed by State Board of Technical Education and Training AP from time to time before commencement of 4th semester.

A candidate is eligible to appear for the 4th semester examination if he/she

- a) Puts the required percentage of attendance in the 4th semester
- b) Should not have failed in more than four Courses in 1st year

For IVC & ITI Lateral Entry Students:

- a) A candidate is eligible to appear for the 4th semester examination if he/she puts the required percentage of attendance in the 4th semester
- b) A candidate is eligible to appear for the 4th semester examination if he/she clears at least two subjects in third semester.
- iv) A candidate shall be promoted to 5th semester provided he / she puts the required percentage of attendance in the 4th semester and pays the examination fee. A candidate, who could not pay the 4th semester examination fee, has to pay the promotion fee as prescribed by State Board of Technical Education and Training from time to time before commencement of 5th semester.

A candidate is eligible to appear for the 5th semester examination if he/she

- a) Puts the required percentage of attendance in the 5th semester
- b) Should get eligibility to appear for 4th Semester examination.
The first backlog exam in 5th semester will be conducted only in instant/supplementary diploma examination.

For IVC& ITI Lateral Entry students:

- a) Puts the required percentage of attendance in the 5th semester
- v) A candidate shall be sent to Industrial training provided he/she puts in the required percentage of attendance in the 4th semester and pay the examination fee/ promotion fee as prescribed by SBTET.

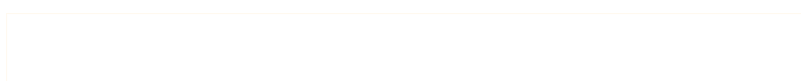

A candidate is eligible to appear for Industrial Training assessment (Seminar/Viva-voce)

- a) Puts the required percentage of attendance, i.e., 90% in 6th semester Industrial Training

For IVC & ITI Lateral Entry students:

- a) Puts the required percentage of attendance, i.e., 90% in 6th semester Industrial Training.
- b) should get eligibility to appear for 5th Semester Examination.

B) For Diploma Courses of 3 ½ Years duration (MET/ CH/ CHPP/ CHPC/ CHOT/ TT):

- i. A candidate shall be permitted to appear for 1st year examination provided he / she puts in 75% attendance (which can be condoned on Medical grounds upto 10%) i.e. attendance after condonation on Medical grounds should not be less than 65% and pay the examination fee.
- ii. A candidate shall be promoted to 3rd semester if he/she puts the required percentage of attendance in the 1st year and pays the examination fee. A candidate who could not pay the 1st year examination fee has to pay the promotion fee as prescribed by State Board of Technical Education and Training from time to time before commencement of 3rd semester.
- iii. A candidate shall be promoted to 4th semester provided he/she puts the required percentage of attendance in the 3rd semester and pay the examination fee. A candidate, who could not pay the 3rd semester exam fee, has to pay the promotion fee as prescribed by State Board of Technical Education and Training from time to time before commencement of 4th semester.

A candidate is eligible to appear for the 4th semester exam if he/she

- a). Puts the required percentage of attendance in the 4th semester
- b). Should not have failed in more than Four backlog Courses of 1st year.

For IVC & ITI Lateral Entry students:

- a) Puts the required percentage of attendance in the 4th semester
- iv. A candidate shall be promoted to 5th semester industrial training provided he / she puts the required percentage of attendance in the 4th semester and pays the examination fee. A candidate, who could not pay the 4th semester examination fee, has to pay the promotion fee as prescribed by State Board of Technical Education and Training from time to time before commencement of 5th semester.
- v. Promotion from 5th to 6th semester is automatic (i.e., from 1st spell of Industrial Training to 2nd spell) provided he/she puts the required percentage of attendance, which in this case i.e., 90 % of attendance and attends for the VIVA-VOCE examination at the end of training.
- vi. A candidate shall be promoted to 7th semester provided he / she puts the required percentage of attendance in the 6th semester and pays the examination fee. A candidate, who could not pay the 6th semester examination fee, has to pay the promotion fee as prescribed by State Board of Technical Education and Training from time to time before commencement of 7th semester.



- vii. A candidate shall be promoted to 7th semester of the course provided he/she has successfully completed both the spells of Industrial Training.
A candidate is eligible to appear for 7th semester examination if he/she
- a) Puts in the required percentage of attendance in the 7th semester
 - b) Should get eligibility to appear for 4th semester Examination.

For IVC & ITI Lateral Entry students:

- a) Puts in the required percentage of attendance in the 7th semester
- b) Should not have failed more than four backlog Courses of 3rd Semester

C) For Diploma Courses of 3 ½ Years duration (BM):

The same rules which are applicable for conventional courses also apply for this course. The industrial training in respect of this course is restricted to one semester (6 months) after the 6th semester (3 years) of the course.

- i. A candidate shall be permitted to appear for first year examination provided he / she puts in 75% attendance (which can be condoned on Medical grounds upto 10%) i.e. attendance after condonation on Medical grounds should not be less than 65% and pay the examination fee.
 - ii. A candidate shall be promoted to 3rd semester if he/she puts the required percentage of attendance in the first year and pays the examination fee. A candidate who could not pay the first year examination fee has to pay the promotion fee as prescribed by State Board of Technical Education and Training from time to time before commencement of 3rd semester.
 - iii. A candidate shall be promoted to 4th semester provided he/she puts the required percentage of attendance in the 3rd semester and pay the examination fee. A candidate who could not pay the 3rd semester examination fee, has to pay the promotion fee as prescribed by State Board of Technical Education and Training from time to time before commencement of 4th semester.
A candidate is eligible to appear for the 4th semester examination if he/she
- a) Puts in the required percentage of attendance in the 4th semester
 - b) Should not have failed in more than Four backlog Courses of 1st year

For IVC & ITI Lateral Entry Students:

A candidate is eligible to appear for the 4th semester examination if he/she puts the required percentage of attendance in the 4th semester

- iv. A candidate shall be promoted to 5th semester provided he / she puts the required percentage of attendance in the 4th semester and pays the examination fee. A candidate, who could not pay the 4th semester examination fee, has to pay the promotion fee as prescribed by State Board of Technical Education and Training from time to time before commencement of 5th semester.
A candidate is eligible to appear for the 5th semester exam if he/she
- a) Puts in the required percentage of attendance in the 5th semester.

- b) Should get eligibility to appear for 4th Semester examination.

For IVC & ITI Lateral Entry students:

- a) Puts in the required percentage of attendance in the 5th semester.
- b) Should not have failed in more than Four backlog Courses of 3rd Semester.
- v. A candidate shall be promoted to 6th semester provided he/she puts in the required percentage of attendance in the 5th semester and pays the examination fee.
A candidate who could not pay the 5th semester examination fee, has to pay the promotion fee as prescribed by State Board of Technical Education and Training from time to time before commencement of 6th semester.

A candidate is eligible to appear for 6th semester examination

- a) Puts in the required percentage of attendance in 6th semester and
- b) should get eligibility to appear for 4th Semester Examination.

For IVC & ITI Lateral Entry students:

- a) Puts in the required percentage of attendance in 6th semester.
- b) Should get eligibility to appear for 5th Semester Examination.
- vi. A candidate shall be promoted to 7th semester provided he/she puts in the required percentage of attendance in 6th semester and pay the examination fee. A candidate, who could not pay the 6th semester examination fee, has to pay the promotion fee prescribed by SBTET from time to time before commencement of the 7th semester (Industrial Training).

A candidate is eligible to appear for 7th semester Industrial Training assessment (Seminar/Viva-voce) if he/she --

- a) Puts in the required percentage of attendance, ie., 90% in 7th semester Industrial Training
- b) Should get eligibility to appear for 4th Semester Examination.

For IVC & ITI Lateral Entry students:

- a) Puts in the required percentage of attendance, ie., 90% in 7th semester Industrial Training.
- b) Should get eligibility to appear for 5th Semester Examination.

Important Note:

Seminar/Viva-voce should not be conducted for Not-Eligible Candidates, till the candidate gets eligibility. However, the record of internal Assessment for Industrial Training for 260 marks shall be maintained at Institution Level for all candidates and the data is to be uploaded only for eligible candidates. For not eligible candidates the data is to be uploaded as and when the candidate gets eligibility.

Other Details

- a) In case a candidate does not successfully complete the Industrial training, he / she will have to repeat the training at his / her own cost.

- b) The First spell of Industrial training shall commence 10 days after the completion of the last theory examination of 4th Semester.
- c) The Second spell of Industrial training shall commence within 10 days after the completion of first spell of Industrial training.

4.13. Students Performance Evaluation

Successful candidates shall be awarded the Diploma under the following divisions of pass.

- a) First Class with Distinction shall be awarded to the candidates who secure an overall aggregate of 75% marks and above.
- b) First Class shall be awarded to candidates who secure overall aggregate of 60% marks and above and below 75% marks.
- c) Second Class shall be awarded to candidates who secure a pass with an overall aggregate of below 60% and above 50% of marks.
 - i. The Weightage of marks for various year/Semesters which are taken for computing overall aggregate shall be 25% of I year marks + 100% of 3rd and subsequent Semesters.
 - ii. In respect IVC & ITI Lateral Entry candidates who are admitted directly into diploma course at the 3rd semester (i.e., second year) level the aggregate of (100%) marks secured at the 3rd and subsequent semesters of study shall be taken into consideration for determining the overall percentage of marks secured by the candidates for award of class/division.
- d) Second Class shall be awarded to all students, who fail to complete the Diploma in the regular 3 years/ 3 ½ years and four subsequent examinations, from the year of first admission.

14. EXAMINATION FEE SCHEDULE:

The examination fee should be as per the notification issued by State Board of Technical Education and Training, AP from time to time.

15. Structure of Examination Question Paper:

I. Formative assessment (Internal examination)

a) For theory Courses:

Three unit tests for first year and two unit tests for semesters shall be conducted with a duration of 90 minutes for each test for maximum marks of 40. It consists of part A and Part B.

Part A contains five questions and carries 16 marks. Among these five questions first question consists of four objective items like one word or phrase answer/filling-in the blanks/true or false etc with one mark for each question. The other four questions are short answer questions and carry three marks each.

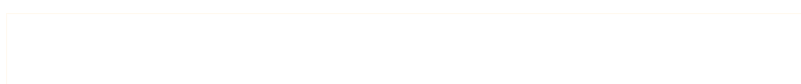

Part B carries 24 marks and consists of three questions with internal choice i.e., Either/Or type, and each question carries 8 marks.

The sum of marks of 3 tests for 1 year and 2 tests for semesters shall be reduced to 20 marks in each Course for arriving at final sessional marks.

b) For drawing Courses:

For 1 year:

Three-unit tests with duration of 90 minutes and for maximum marks of 40 marks shall be conducted for first year. It consists of part A and Part B.

Part A consists four questions for maximum marks of 16 and each question carries four marks (4×4 marks=16 marks).

Part B carries maximum marks of 24 and consists of five questions while the student shall answer any three questions out of these five questions. Each question in this part carries a maximum mark of 8, (3×8 marks=24 marks).

The sum of marks obtained in 3-unit test marks shall be reduced to 20 marks for arriving at final sessional marks. Remaining 20 marks are awarded by the Course teacher based on the student's performance during regular class exercise.

For semester: Two-unit tests with duration of 90 minutes and for maximum marks of 40 marks shall be conducted. The sum of marks obtained in 2-unit test marks shall be reduced to 20 marks for arriving at final sessional marks. Remaining 20 marks are awarded by the Course teacher based on the student's performance during regular class exercise.

c) For Laboratory /workshop: 50% of total marks for the Course shall be awarded based on continuous assessment of the student in laboratory/workshop classes and the remaining 50% shall be based on the sum of the marks obtained by the students in two tests.

II. Summative assessment (End examination)

The question paper for theory examination is patterned in such a manner that the Weightage of periods/marks allotted for each of the topics for a particular Course be considered. End Examination paper is of 3 hours duration.

a) **Each theory paper consists of Section 'A' and 'B' .**

Section 'A' with Max marks of 30, contains 10 short answer questions. All questions are to be answered and each carries 3 marks, i.e., 10 x 3 = 30.

Section 'B' with Max marks of 50 contains 8 essay type questions. Only 5 questions are to be answered and each carries 8 marks. Max. Marks: 5 x 8 = 40.

Thus the total marks for theory examination shall be: 80.

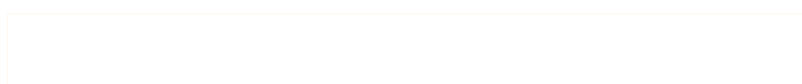

b) **For Engineering Drawing Course (107) consist of section 'A' and section 'B'.**

Section 'A' with max marks of 20, contains four (4) questions. All questions in section 'A' are to be answered to the scale and each carries 5 marks, i.e. $4 \times 5 = 20$.

Section 'B' with max marks of 40, contains six (6) questions. The student shall answer any four (4) questions out of the above six questions and each question carries 10 Marks, i.e., $4 \times 10 = 40$.

c) **Practical Examinations**

For Workshop practice and Laboratory Examinations, Each student has to pick up a question paper distributed by Lottery System.

Max. Marks for an experiment / exercise	:	50
Max. Marks for VIVA-VOCE	:	10
Total Max. Marks	:	60

In case of practical examinations with 50 marks, the marks shall be distributed as

Max. Marks for an experiment / exercise	:	25
Max. Marks for VIVA-VOCE	:	05
Total Max. Marks	:	30

In case of any change in the pattern of question paper, the same shall be informed sufficiently in advance to the candidates.

d) **Note: Evaluation for Laboratory Courses, other than Drawing courses:**

- I. Instruction (teaching) in laboratory courses (except for the course on Drawing) hereafter shall be task/competency based as delineated in the Laboratory sheets, prepared by SBTET, AP and posted in its website.
- II. Internal assessment for Laboratory shall be done on basis of task/s performed by the student as delineated in the laboratory sheets, prepared by SBTET, AP and posted in its website.
- III. Question paper for End semester Evaluation shall be prepared as per SBTET rules in vogue.

16. ISSUE OF MEMORANDUM OF MARKS

All candidates who appear for the end examination will be issued memorandum of marks without any payment of fee. However candidates who lose the original memorandum of marks have to pay the prescribed fee to the Secretary, State Board of Technical Education and Training, A.P. for each duplicate memo from time to time.

17. MAXIMUM PERIOD FOR COMPLETION OF DIPLOMA Programmes:

Maximum period for completion of the diploma courses is twice the duration of the course from the date of First admission (includes the period of detention and discontinuation of studies by student etc) failing which they will have to forfeit the claim for qualifying for the award of Diploma (They will not be permitted to appear for examinations after that date). This rule applies for all Diploma courses of 3 years and $3 \frac{1}{2}$ years of engineering and non-engineering courses.



18. ELIGIBILITY FOR AWARD OF DIPLOMA

A candidate is eligible for award of Diploma Certificate if he / she fulfil the following academic regulations.

- i. He / She pursued a course of study for not less than 3 / 3 ½ academic years & not more than 6 / 7 academic years.
- ii. He / she has completed all the Courses.
Students who fail to fulfil all the academic requirements for the award of the Diploma within 6 / 7 academic years from the year of admission shall forfeit their seat in the course & their seat shall stand cancelled.

For IVC & ITI Lateral Entry students:

- i. He / She pursued a course of study for not less than 2 / 2 ½ academic years & not more than 4 / 5 academic years.
- ii. He / she has completed all the Courses.

Students who fail to fulfil all the academic requirements for the award of the Diploma within 4 / 5 academic years from the year of admission shall forfeit their seat in the course & their seat shall stand cancelled.

19. ISSUE OF PHOTO COPY OF VALUED ANSWER SCRIPT, RECOUNTING& REVERIFICATION:

A) FOR ISSUE OF PHOTO COPIES OF VALUED ANSWER SCRIPTS

- I. A candidate desirous of applying for Photo copy of valued answer script/s should apply within prescribed date from the date of the declaration of the result.
- II. Photo copies of valued answer scripts will be issued to all theory Courses and Drawing Course(s).
- III. The Photo copy of valued answer script will be dispatched to the concerned candidate's address as mentioned in the application form by post.
- IV. No application can be entertained from third parties.

B) FOR RE-COUNTING(RC) and RE-VERIFICATION(RV) OF THE VALUED ANSWER SCRIPT

- i. A candidate desirous of applying for Re-verification of valued answer script should apply within prescribed date from the date of the declaration of the result.
- ii. Re-verification of valued answer script shall be done for all theory Courses and Drawing Course(s).
- iii. The Re-verification committee constituted by the Secretary, SBTETAP with Course experts shall re-verify the answer scripts.

I. RE-COUNTING

The Officer of SBTET will verify the marks posted and recount them in the already valued answer script. The variations if any will be recorded separately, without making any changes on the already valued answer script. The marks awarded in the original answer script are maintained (hidden).

II. RE-VERIFICATION

- (i) The Committee has to verify the intactness and genuineness of the answer script(s) placed for Re-verification.
 - (ii) Initially single member shall carry out the re-verification.
 - (iii) On re-verification by single member, if the variation is less than 12% of maximum marks, and if there is no change in the STATUS in the result of the candidate, such cases will not be referred to the next level ie., for 2-Tier evaluation.
 - (iv) On re-verification by a single member, if the variation is more than 12% of maximum marks, it will be referred to 2-Tier evaluation.
 - (v) If the 2-Tier evaluation confirms variation in marks as more than 12% of maximum marks, the variation is considered as follows:
 - a) If the candidate has already passed and obtains more than 12% of the maximum marks on Re-verification, then the variation is considered.
 - b) If the candidate is failed and obtains more than 12% of the maximum marks on Re-verification and secured pass marks on re-verification, then the status of the candidate changes to PASS.
 - c) If a candidate is failed and obtains more than 12% of the maximum marks on Re-verification and if the marks secured on re-verification are still less than the minimum pass marks, the status of the candidate remain FAIL only.
 - (vii) After Re-verification of valued answer script the same or change if any therein on Re-verification, will be communicated to the candidate.
 - (viii) On Re-verification of Valued Answer Script if the candidate's marks are revised, the fee paid by the candidate will be refunded or else the candidate has to forfeit the fee amount.
- Note:** No request for Photo copies/ Recounting /Re-verification of valued answer script would be entertained from a candidate who is reported to have resorted to Malpractice in that examination.

4.20. Mal Practice Cases:

If any candidate resorts to Mal Practice during examinations, he / she shall be booked and the Punishment shall be awarded as per SBTETAP rules and regulations in vogue.

4.21. Discrepancies/ Pleas:

Any Discrepancy /Plea regarding results etc., shall be represented to the SBTETAP within one month from the date of issue of results. Thereafter, no such cases shall be entertained in any manner.

4.22. Issue of Duplicate Diploma

If a candidate loses his/her original Diploma Certificate and desires a duplicate to be issued he/she should produce written evidence to this effect. He / she may obtain a duplicate from the Secretary, State Board of Technical Education and Training, A.P., on payment of prescribed fee and on production of an affidavit signed before a First Class Magistrate (Judicial) and non-traceable certificate from the Department of Police. In case of damage of



original Diploma Certificate, he / she may obtain a duplicate certificate by surrendering the original damaged certificate on payment of prescribed fee to the State Board of Technical Education and Training, A.P.

In case the candidate cannot collect the original Diploma within 1 year from the date of issue of the certificate, the candidate has to pay the penalty prescribed by the SBTET AP from time to time.

4.23. Issue of Migration Certificate and Transcripts:

The Board on payment of prescribed fee will issue these certificates for the candidates who intend to prosecute Higher Studies in India or Abroad.

4.25. General

- i. The Board may change or amend the academic rules and regulations or syllabi at any time and the changes or amendments made shall be applicable to all the students, for whom it is intended, with effect from the dates notified by the competent authority.
- ii. All legal matters pertaining to the State Board of Technical Education and Training, AP are within the jurisdiction of Mangalagiri.
- iii. In case of any ambiguity in the interpretation of the above rules, the decision of the Secretary, SBTET, A.P., Mangalagiri is final.

--:oOo:--

C-23 Curriculum for DECE

VISION

Develop Electronics and Communication Engineering professionals competent to face the global challenges in a progressive environment conducive to learn technical knowledge, skills blended with ethics and values, to serve the society and to better it for a happy and comfortable living.

MISSION

M1	To provide a competitive learning environment, through a need based curriculum designed in collaboration with industry, conducive for high quality education emphasising on transfer of knowledge and skill development essential for the profession and the society as well.
M2	To nurture higher order leadership qualities and ethics and values in students to enable them to be leaders in their chosen professions while maintaining the highest level of ethics.
M3	To encourage the spirit of inquisition to promote innovation and entrepreneurship strengthened with life skills to sustain the stress.
M4	To foster effective interactions and networking with all the stake holders so as to work towards the growth and sustainability of the society and environment.

Programme Educational Objectives (PEOs)

Diploma in Electronics and Communication Engineering programme is steadfast to transform students in to competent professionals with qualities of good human values and responsible citizens.

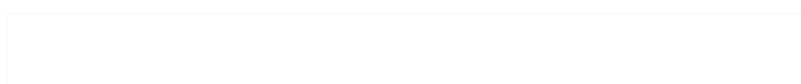

On completion of the Diploma programme, the students should have acquired the following characteristics

PEO1	To apply technical knowledge and management principles in analyzing and planning problems in the field of electronics and Communication Engineering while ensuring maximization of economic benefits to society and minimization of damage to ecology and environment
PEO2	To be life-long learners with sprit of enquiry and zeal to acquire new knowledge and skills so as to remain contemporary and posses required professional skills.
PEO3	To enhance entrepreneurial, communication and other soft skills, which will enable them to work globally as leaders, team members and contribute to nation building for the betterment of the society.
PEO4	To make them strongly committed to the highest levels of professional ethics and focus on ensuring quality, adherence to public policy and law, safety, reliability and environmental sustainability in all their professional activities

PROGRAMME OUTCOMES(POs)

1. **Basic and discipline specific knowledge:** Apply knowledge of basic mathematics, science and engineering fundamentals and engineering specialization to solve the engineering problems.
2. **Problem analysis:** Identify and analyse well-defined engineering problems using codified standard methods
3. **Design/Development of solutions:** Design solutions for well-defined technical problems and assist with the design of systems components or processes to meet specified needs
4. **Engineering tools, Experimentation and Testing:** Apply modern engineering tools and appropriate technique to conduct standard tests and measurements.
5. **Engineering practices for society, sustainability and environment:** Apply appropriate technology in context of society, sustainability, environment and ethical practices.
6. **Project Management:** Use engineering management principles individually, as a team member or a leader to manage projects and effectively communicate about well defined engineering activities.
7. **Life-long learning:** Ability to analyse individual needs and engaging updating in the context of technological changes.

PROGRAMME SPECIFIC OUTCOMES(PSOs)

1. An ability to understand the concepts of basic Electronics & Communication Engineering and to apply them to various areas like Signal processing, VLSI, Embedded systems, Communication Systems, Digital & Analog Devices, etc.
2. An ability to solve complex Electronics and Communication Engineering problems, using latest hardware and software tools, along with analytical skills to arrive cost effective and appropriate solutions.

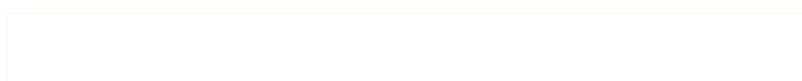

3. Wisdom of social and environmental awareness along with ethical responsibility to have a successful career in the field of Electronics and Communication Engineering and to sustain passion and zeal for real-world applications in the field of Electronics using optimal resources as an Entrepreneur.



DIPLOMA IN ELECTRONICS & COMMUNICATION ENGINEERING
SCHEME OF INSTRUCTIONS AND EXAMINATIONS
FIRST YEAR

Subject Code	Name of the Subject	Instruction period / week		Total Period /year	Scheme of Examination			
		Theory	Practical/ Tutorial		Duration (hours)	Sessional Marks	End Exam Marks	Total Marks
THEORY								
EC-101	English	3	-	90	3	20	80	100
EC-102	Engineering Mathematics - I	5	-	150	3	20	80	100
EC-103	Engineering Physics	3	-	90	3	20	80	100
EC-104	Engineering Chemistry & Environmental Studies	3	-	90	3	20	80	100
EC-105	Electronic Components and Devices	5	-	150	3	20	80	100
EC-106	Elements of Electrical Engineering	5	-	150	3	20	80	100
PRACTICAL								
EC-107	Engineering Drawing	-	3	90	3	40	60	100
EC-108	Electronic components and Devices Lab	-	3	90	3	40	60	100
EC-109	Physics Lab	-	1.5	45	3 (1.5+1.5)	20	30	100 (50+50)
EC-110	Chemistry Lab		1.5	45		20	30	
EC-111	Computer Fundamentals Lab	-	3	90	3	40	60	100
EC-112	Electrical Engineering Lab		3	90	3	40	60	100
	Activities		3	90	-	-	-	-
	TOTAL	24	18	1260		320	780	1100

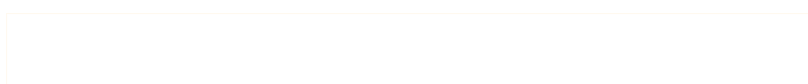

DIPLOMA IN ELECTRONICS & COMMUNICATION ENGINEERING
SCHEME OF INSTRUCTIONS AND EXAMINATIONS
III SEMESTER

Subject Code	Name of the Subject	Instruction period / week		Total Period / Sem	Scheme of Examination			
		Theory	Practical		Duration (hours)	Sessional Marks	End Exam Marks	Total Marks
THEORY								
EC- 301	Engineering Mathematics - II	4	-	60	3	20	80	100
EC -302	Electronic Circuits -I	4	-	60	3	20	80	100
EC -303	Digital Electronics	4	-	60	3	20	80	100
EC-304	Analog and Digital Communication Systems	5	-	75	3	20	80	100
EC-305	Network Analysis	5	-	75	3	20	80	100
EC - 306	Programmng in C and MATLAB	4	-	60	3	20	80	100
PRACTICAL								
EC-307	Electronic Circuits-I & Network Analysis Lab	-	4	60	3	40	60	100
EC-308	Digital Electronics lab	-	3	45	3	40	60	100
EC-309	Analog and Digital Communication systems Lab	-	3	45	3	40	60	100
EC-310	Programmng in C and MATLAB Practice	-	3	45	3	40	60	100
	Activities		3	45	-	-	-	-
TOTAL		26	16	630	-	280	720	1000



DIPLOMA IN ELECTRONICS & COMMUNICATION ENGINEERING
SCHEME OF INSTRUCTIONS AND EXAMINATIONS
IV SEMESTER

Subject Code	Name of the Subject	Instruction period / week		Total Period / Sem	Scheme of Examination			
		Theory	Practical		Duration (hours)	Sessional Marks	End Exam Marks	Total Marks
THEORY								
EC-401	Electronic Circuits-II	5	-	75	3	20	80	100
EC-402	Microcontrollers and Interfacing	5	-	75	3	20	80	100
EC-403	Microwave & Satellite Communication systems	5	-	75	3	20	80	100
EC-404	IoT and Sensors	4	-	60	3	20	80	100
EC-405	Digital Logic Design through Verilog HDL	5		75	3	20	80	100
PRACTICAL								
EC-406	Electronic Circuits-II Lab	-	3	45	3	40	60	100
EC-407	Microcontrollers and Interfacing Lab	-	3	45	3	40	60	100
EC-408	Communication skills	-	3	45	3	40	60	100
EC-409	IoT and Sensors Lab	-	3	45	3	40	60	100
EC-410	Verilog HDL Lab	-	3	45	3	40	60	100
	Activities		3	45	-	-	-	-
TOTAL		24	18	630	-	300	700	1000

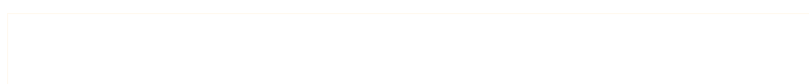

DIPLOMA IN ELECTRONICS & COMMUNICATION ENGINEERING
SCHEME OF INSTRUCTIONS AND EXAMINATIONS
V SEMESTER

Subject Code	Name of the Subject	Instruction period / week		Total Periods / Sem	Scheme of Examination			
		Theory	Practical		Duration (hours)	Sessional Marks	End Exam Marks	Total Marks
EC -501	Industrial Management & Business Analytics	4		60	3	20	80	100
EC-502	Embedded Systems	5	-	75	3	20	80	100
EC-503	Optical & Mobile Communications	5	-	75	3	20	80	100
EC-504	Industrial Electronics & Automation	5	-	75	3	20	80	100
EC-505	Data Communication & Computer Networks	5	-	75	3	20	80	100
EC-506	Embedded Systems lab	-	3	45	3	40	60	100
EC-507	Industrial Electronics & Automation Lab	-	3	45	3	40	60	100
EC-508	Life Skills	-	3	45	3	40	60	100
EC-509	Data Communication & Computer Networks	-	3	45	3	40	60	100
EC-510	Project Work	-	3	45	3	40	60	100
	Activities		3	45	-	-	-	-
	TOTAL	24	18	630	-	300	700	1000

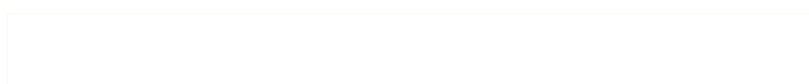

**DIPLOMA IN ELECTRONICS & COMMUNICATION ENGINEERING
SCHEME OF INSTRUCTIONS AND EXAMINATIONS
C-23-VI Semester**

EC-601 INDUSTRIAL TRAINING

Sl.No.	Subject	Duration	Scheme of evaluation		
			Item	Nature	Max. Marks
1	Industrial Training	6 months	1.First Assessment at Industry (After 12 Weeks)	Assessment of learning outcomes by both the faculty and training mentor of the industry	120
			2.Second Assessment at the Industry (After 20 weeks))	Assessment of learning outcomes by both the faculty and training mentor of the industry	120
			Final Summative assessment at institution level	Training Report	20
				Demonstration of any one of the skills listed in learning outcomes	30
				Viva Voce	10
TOTAL MARKS					300

The Industrial Training shall carry maximum 300 marks. Pass mark is 50% in first and second assessment put together and also 50% in final summative assessment at the institution level.

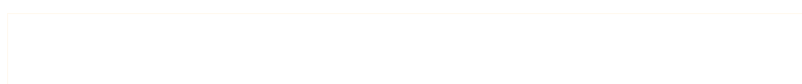

FIRST YEAR



FIRST YEAR

Subject Code	Name of the Subject	Instruction period / week		Total Period /year	Scheme of Examination			
		Theory	Practical		Duration (hours)	Sessional Marks	End Exam Marks	Total Marks
THEORY								
EC-101	English	3	-	90	3	20	80	100
EC-102	Engineering Mathematics - I	5	-	150	3	20	80	100
EC-103	Engineering Physics	3	-	90	3	20	80	100
EC-104	Engineering Chemistry & Environmental Studies	3	-	90	3	20	80	100
EC-105	Electronic components and Devices	5	-	150	3	20	80	100
EC-106	Elements of Electrical Engineering	5	-	150	3	20	80	100
PRACTICAL								
EC-107	Engineering Drawing	-	3	90	3	40	60	100
EC-108	Electronic components and Devices Lab	-	3	90	3	40	60	100
EC-109	Physics Lab	-	1.5	45	3 (1.5+1.5)	20	30	100 (50+50)
EC-110	Chemistry Lab		1.5	45		20	30	
EC-111	Computer Fundamentals Lab	-	3	90	3	40	60	100
EC-112	Electrical Engineering Lab		3	90	3	40	60	100
	Activities		3	90	-	-	-	-
	TOTAL	24	18	1260		320	780	1100

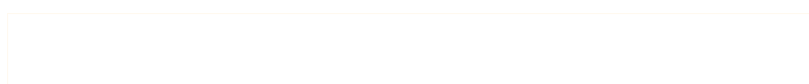

English

Course Code	Course Title	No.of Periods/Week	Total No.of Periods	Marks for FA	Marks for SA
EC-101	English	3	90	20	80

S. No.	Unit Title	No of	COs Mapped
1	English for Employability	8	CO1, CO2, CO3, CO4,CO5
2	Living in Harmony	8	CO1, CO2, CO3, CO4,CO5
3	Connect with Care	8	CO1, CO2, CO3, CO4, CO5
4	Humour for Happiness	8	CO1, CO2, CO3, CO4, CO5
5	Never Ever Give Up!	8	CO1, CO2, CO3, CO4, CO5
6	Preserve or Perish	9	CO1, CO2, CO3, CO4, CO5
7	The Rainbow of Diversity	8	CO1, CO2, CO3, CO4, CO5
8	New Challenges- Newer Ideas	8	CO1, CO2, CO3, CO4, CO5
9	The End Point First!	8	CO1, CO2, CO3, CO4, CO5
10	The Equal Halves	8	CO1, CO2, CO3, CO4, CO5
11	Dealing with Disaster	9	CO1, CO2, CO3, CO4, CO5
Total Periods		90	

Course Objectives	- To improve grammatical knowledge and enrich vocabulary.
	- To develop effective reading, writing and speaking skills.
	- To comprehend themes related to Personality, Society, Environment to exhibit Universal Human Values.

CO No.	Course Outcomes
CO1	Apply and use various grammatical rules and concepts to communicate in academic, professional and everyday situations
CO2	Use appropriate vocabulary in various contexts.
CO3	Read and comprehend different forms of academic, professional and everyday texts.
CO4	Communicate effectively in speaking and writing in academic, professional and everyday situations.
CO5	Display human values by applying the knowledge of themes related to Self, Society, Science and Environment for holistic and harmonious living through communication.

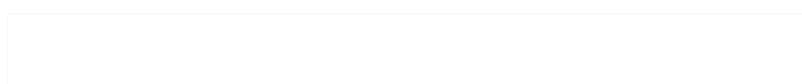

CO-PO Matrix

Course Code Common-101	Course Title: English Number of Course Outcomes: 4			No. of Periods: 90	
POs	Mapped with CO No.	CO Periods Addressing PO in Column 1		Level of Mapping (1,2,3)	Remarks
		Number	Percentage		
PO1		Not directly Applicable for English course, however activities that use content from science and technology relevant to the Programme taken up by the student shall be exploited for communication in the Course.			
PO2					
PO3					
PO4					
PO5	CO5	16	18%		>50%: Level 3
PO6	CO1, CO2, CO3, CO4,	52	58%		21-50%: Level 2
PO7	CO1, CO2, CO3, CO4,CO5	22	24%		Up to 20%: Level 1

Level 3 – Strongly Mapped, Level 2- Moderately Mapped; Level 1- Slightly Mapped

Learning Outcomes

1. English for Employability

- 1.1. Perceive the need for improving communication in English for employability
- 1.2. Use adjectives and articles effectively while speaking and in writing
- 1.3. Write simple sentences

2. Living in Harmony

- 2.1. Develop positive self-esteem for harmonious relationships
- 2.2. Use affixation to form new words
- 2.3. Use prepositions and use a few phrasal verbs contextually

3. Connect with Care

- 3.1. Use social media with discretion
- 3.2. Speak about abilities and possibilities
- 3.3. Make requests and express obligations
- 3.4. Use modal verbs and main verbs in appropriate form
- 3.5. Write short dialogues for everyday situations

4. Humour for Happiness

- 4.1. Realize the importance of humour for a healthy living
- 4.2. Improve vocabulary related to the theme
- 4.3. Acquire reading and speaking skills
- 4.4. Frame sentences with proper Subject – Verb agreement
- 4.5. Understand the features of a good paragraph and learn how to gather ideas as a preliminary step for writing a good paragraph.

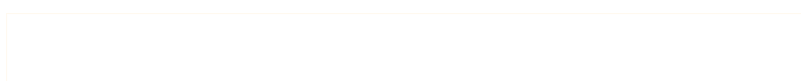

5. Never Ever Give Up!

- 5.1. Learn to deal with failures in life
- 5.2. Use the present tense form for various every day communicative functions such as speaking and writing about routines, professions, scientific descriptions and sports commentary
- 5.3. Write paragraphs with coherence and other necessary skills

6. Preserve or Perish

- 6.1. Understand the ecological challenges that we face today and act to save the environment.
- 6.2. Narrate / Report past events
- 6.3. Develop vocabulary related to environment
- 6.4. Write e-mails

7. The Rainbow of Diversity

- 7.1. Appraise and value other cultures for a happy living in multi-cultural workspace
- 7.2. Understand the usage of different types of sentences
- 7.3. Ask for or give directions, information, instructions
- 7.4. Use language to express emotions in various situations
- 7.5. Write letters in various real life situations

8. New Challenges – Newer Ideas

- 8.1. Understand the functional difference between Active Voice and Passive Voice
- 8.2. Use Passive Voice to speak and write in various contexts
- 8.3. Understand the major parts and salient features of an essay
- 8.4. Learn about latest innovations and get motivated

9. The End Point First!

- 9.1. Understand the importance of setting a goal in life
- 9.2. Report about what others have said both in speaking and writing
- 9.3. Write an essay following the structure in a cohesive and comprehensive manner
- 9.4. Apply the words related to Goal Setting in conversations and in life

10. The Equal Halves

- 10.1. Value the other genders and develop a gender-balanced view towards life
- 10.2. Identify the use of different conjunctions in synthesising sentences
- 10.3. Write various types of sentences to compare and contrast the ideas
- 10.4. Apply the knowledge of sentence synthesis in revising and rewriting short essays
- 10.5. Develop discourses in speech and writing

11. Dealing with Disasters

- 11.1. Speak and write about different kinds of disasters and the concept of disaster management
- 11.2. Generate vocabulary relevant to disaster management and use it in sentences
- 11.3. Analyze an error in a sentence and correct it
- 11.4. Learn and write different kinds of reports



Textbook:

'INTERACT' (A Text book of English for I Year Engineering Diploma Courses) - by SBTET, AP

Reference Books:

Martin Hewings : *Advanced Grammar in Use*, Cambridge University Press

Murphy, Raymond : *English Grammar in Use*, Cambridge University Press

Sidney Greenbaum : *Oxford English Grammar*, Oxford University Press

Wren and Martin (Revised by N.D.V. Prasad Rao) : *English Grammar and Composition*, Blackie ELT Books, S. Chand and Co.

Sarah Freeman : *Strengthen Your Writing*, Macmillan

End Exam = 80 Marks

PART-A: 10 Questions 3 marks each =30 Marks

PART-B: 5 out of 8 are to be answered : 10 marks each =50 Marks

Unit Tests 1,2,3 @ 40 Marks each

Part A: 16 marks: One question for 4 marks + 4 questions for 3 marks each (4+12 Marks=16 Marks)

Part B: 24 marks: 3 questions for 8 marks each with internal choice. (3X8 Marks= 24 Marks)

Weightage Table : C23-COMMON-101: English

S. No	Name of the Unit	Periods Allocated (Total 90 periods)	Weightage of Marks Allocated (Short + Long Answer question)	Weightage (Long answer questions) @10 Marks	Marks Wise Distribution of Weightage (Short answer questions) @3 Marks				CO's Mapped
					R	U	A p	A n	
1	English for Employability	8	20+9	2	3+3		3		CO1,CO2, CO3,CO4, CO5
2	Living in Harmony	8							CO1,CO2, CO3,CO4, CO5
3	Connect with Care	8							CO1,CO2, CO3,CO4, CO5
4	Humour for Happiness	8	20+9	2		3		3	CO1,CO2, CO3,CO4, CO5
5	Never Ever Give Up!	8							CO1,CO2, CO3,CO4, CO5
6	Preserve or Perish	9							CO1,CO2, CO3,CO4, CO5
7	The Rainbow of Diversity	8							CO1,CO2, CO3,CO4, CO5
8	New Challenges -	8		1				3	

	Newer Ideas		10+3						CO3,CO4, CO5
9	The End Point First!	8	10+3	1		3			CO1,CO2, CO3,CO4, CO5
10	The Equal Halves	8	10+3	1		3			CO1,CO2, CO3,CO4, CO5
11	Dealing with Disasters	9	10+3	1			3		CO1,CO2, CO3,CO4, CO5
Short Answer Questions			30		6	6	15	3	
Long Answer Questions			80	8 *					
Total			110						

*(Integration of the cognitive skills of Understanding, Applying & Analysing)

C23- COMMON-101: ENGLISH: END EXAM (80 Marks)			
Question Paper Pattern (Division of Topics: Question wise)			
S.No. of the Question	Weightage of Marks	Language Skill / grammatical Concept of the question	Sub aspects & Description
PART-A ; 10 questions X3 marks = 30 Marks			
1	3 (6 Questions X ½ Mark)	Articles & Prepositions	a) Definite, indefinite articles b) prepositions of place, time, directions
2	3 (6 Questions X ½ Mark)	Vocabulary	Synonyms, Antonyms, affixes, words & phrases, Phrasal Verbs, words matching with meanings, one word substitutions,
3	3 (6 Questions X ½ Mark)	Helping Verbs	a) Primary helping verbs (be/do/have) b) Modal verbs
4	3 (3 questions 1 mark each)	Tenses	Using appropriate Verb forms
5	3 (3 questions 1 mark each)	Voice	Conversion : Active & Passive voice
6	3 (3 questions 1 mark each)	Adjectives	Using appropriate adjective form/ conversion : Degrees of comparison
7	3 (3 questions 1 mark each)	Types of sentences & positive, negative sentences	Conversion from one type of sentence to the other , making negative sentence
8	3 (3 questions 1 mark each)	Syntheses of Sentences / Conjunctions / linkers	Transformation of sentences : Simple, complex & compound sentences / use of linkers/ conjunctions

9	3 (3 questions 1 mark each)	Direct& Indirect Speech	Conversion from Direct to Indirect & Vice versa
10	3 (3 questions 1 mark each)	Correction of Sentences	Remaining grammar aspects (concord & usage based...etc)
PART –B ; 5 QX10 M = 50 Marks			
11	10 Marks	Paragraph Writing	From Units 1,2,3 (theme based- focus on importance English learning and using)
12	10	Giving instructions or directions	From Units 4,5,6,7 Theme based / Situation based /role play/ general topic
13	10	Dialogue writing	
14	10	Essay writing	From Units 8,9,10,11 (theme based)
15	10	Letter writing	Formal / informal letters
16	10	Report Writing	Report on Mini projects/ industrial visits / camps/ events / celebrations
17	10 (2 questions X 5 Marks)	a) E-Mail writing b) Framing questions	a) E mail etiquette b) Wh & Yes-No questions
18	10 (Ten questions 1 mark each)	Reading Comprehension	An unseen piece of prose with 10 questions for reading comprehension check



Model Question Paper: End Exam, C23- Common- 101
SBTET – I Year End Examinations
C23-Common-101: ENGLISH

Time: 3 Hrs.

Max.Marks: 80

PART-A

10X3=30 Marks

Instructions: Answer all the questions and each question carries 3 marks. Marks will be awarded only for the desired and accurate language / grammatical expressions.

1. A) Fill in the blanks with appropriate articles:

My father sent me _____ envelope through _____ messenger and _____ cover contained a bank cheque in my favour.

B) Fill in the blanks with suitable prepositions:

My mother arranged a beautiful flower vase _____ my study table, just beside my computer, _____ which she keeps fresh flowers every day. The vase is made _____ ceramic.

2. A) Give synonyms for the words: i) depressed ii) caricature

B) Give antonyms for the words: i) natural ii) visible

C) Add affixes to the words: i) prefer ii) proper

3. A) Fill in the blanks with suitable Primary Helping Verbs (Be/ do/ have forms):

i) All the books _____ already been sold out.

ii) She paid condonation fees as she _____ not attend the classes regularly last semester.

iii) Why _____ you not giving me reply?

B) Fill in the blanks with suitable Modal verbs based on the clue given in brackets.

i) Pratap is an ambidextrous; he _____ write with his two hands. (ability)

ii) Jyothsna _____ pay the tuition fees by tomorrow. (obligation)

iii) My grandfather _____ to ride a horse in his youth. (Past habit)

4. Fill in the blanks with suitable verb form using the base form given in the brackets.

i) Suma _____ (bring) a pup to the class yesterday.

ii) Johnny _____(play) the piano in a music band every weekend.

iii) Girija _____ (watch) a movie on TV when I visited her last Sunday.

5. Change the voice of the following:

i) My elder brother paid my exam fees yesterday.

ii) These two chapters will be taught in next month.

iii) They are constructing a new house.

6. i) Pacific is _____(big) ocean of all. (Fill in with appropriate degree of the adjective given in the bracket)

ii) No other food item is as nutritious as honey. (Change into Comparative degree)

- iii) Bangalore is one of the beautiful cities of India. (Change into Positive degree)
7. i) You need two thousand rupees to buy a new pair of shoes. Write a polite expression asking your father for money.
- ii) Radhika has been invited for the wedding. (Convert into a negative sentence)
- iii) Our pet pigeons flew away last night. (Convert into a negative sentence)
8. i) Ramesh can't reach on time _____ he travels by a superfast train. (Fill in with suitable conjunction)
- ii) Though the long bell was given, the children stayed in the classroom. (Change into a simple sentence)
- iii) Get a ticket on a sleeper coach, and then you can sleep during journey. (Change into a complex sentence)
9. i) Tarun said, " Prathima, I shall return your notes tomorrow". (change into a reported speech)
- ii) Arjun requested his sister Priya not to disturb him while he was studying. (change into a direct speech)
- iii) Teacher said, "Students, why are you talking in the class?" (change into a reported speech)
10. Correct the following sentences:
- i) These flowers are smelling sweet.
- ii) Either the father or his children has arrived home early.
- iii) Every bike rider should abide to the traffic rules.

PART-B

10X5=50Marks

Instructions: a) Answer any FIVE questions and each question carries TEN marks.

b) The criterion for the award of marks is the appropriate content, quality and clarity of expression but not the length of your answer.

11. Write a paragraph in 120 words about the problems you are experiencing in speaking English and your own solutions to overcome them.
12. Write a set of instructions to create a word file and insert a Table using MS office on a computer.
13. Write a dialogue in at least eight turns between a sales person at a readymade garment showroom and you as you want to buy a readymade dress.
14. Write an essay in about 175 words on valuing opposite gender and show mutual respect.
15. Write a letter to the Municipal Commissioner about the menace of street dogs in your area.
16. Imagine that your class had visited an industry / organisation relevant to your branch of Engineering; write a report about the visit to submit to your HOD.
17. a) Write an E-mail to your cousin requesting him/her to send you the diploma study material by a courier or post.

b) Frame THREE 'wh' questions & TWO 'Yes-No' questions from the following passage.

Dolphins are intelligent animals. A dolphin's nose is on top of its head. So, it can easily breathe on the surface of the water. The skin of a dolphin has no scales. It is soft and smooth. They swim in 'pods'; a very large pod is called a 'herd'. They are very social and help each other fight off predators. Dolphins brain has two sides. One side sleeps while the other side stays awake.

18. Read the following passage and answer the questions that follow. Your answer should be accurate, precise and limited to a word or phrase or a simple sentence.

The Indian Army is the land-based branch and the largest component of the Indian Armed Forces. The President of India is the Supreme Commander of the Indian Army, and it is commanded by the Chief of Army Staff (COAS), who is a four-star general. The primary mission of the Indian Army is to ensure national security and national unity, defending the nation from external aggression and internal threats, and maintaining peace and security within its borders. It conducts humanitarian rescue operations during natural calamities and other disturbances, like Operation Surya Hope, and can also be requisitioned by the government to cope with internal threats. It is a major component of national power alongside the Indian Navy and the Indian Air Force. The army has been involved in four wars with neighbouring Pakistan and one with China. Other major operations undertaken by the army include: Operation Vijay, Operation Meghdoot and Operation Cactus.

- a) What is the largest component of Indian Armed Forces?
- b) Who is the four-star general?
- c) "Maintaining internal peace and security is not one of the responsibilities of Indian Army". Is the statement True or False ?
- d) What is the primary mission of the Indian Army?
- e) Name the operation held by the Indian Army during natural disaster.
- f) What are the other two forces mentioned in the passage?
- g) If you were to join Armed forces, which wing do you prefer? State your reason in a sentence.
- h) Pick the word from the passage that would mean: 'forcefulness or violent behavior'
- i) Give the antonym for the word: 'internal'
- j) Suggest a suitable title for the passage in a word or phrase.

-o0o-

C23-EC-101 :English : Bifurcation of Syllabus for UNIT TESTS 1,2,3			
Unit Test	Lessons / Chapters	Grammar / Language aspects (Topics or Short Answer questions)	Writing Skills (Topics for Long answer/ Essay Questions)
U.T 1	Chapters 1,2,3	a) articles & prepositions, b)Vocabulary: Affixes, synonyms, Antonyms, matching meanings, words & phrases, one word substitutes) c)Adjectives (degrees of comparison) d) Main& Auxiliary Verbs e) phrasal verbs/ word order	a) Theme based Paragraph (focus on LSRW skills, importance of English, Self-esteem, SWOC analysis, Social media) b) Dialogue on themes of lessons 2&3 / Dialogue on General topic / a situation c) Reading comprehension
U.T 2	Chapters 4,5,6,7	a) concord b) Tenses c) Types of sentences d) Framing questions e) words &phrases, linkers	a) Theme based paragraph (Humour for happy living, learning from failures, Environmental protection, multi- culture /global culture) b) Letter writing (formal& informal), c) instructions/ directions, E-mail writing
U.T 3	Chapters 8,9,10,11	a) Voice (active &passive) b) Speech(direct& indirect) c) Synthesis of sentences (simple, complex, compound sentences) d) Error analysis e) words &phrases, linkers	a) Theme based paragraph/ Essay writing (Technical innovations, Goal setting, gender sensitivity, dealing with disaster) b) Essay writing, Report writing c) Reading Comprehension
Unit Test Question Paper pattern (40 Marks)	Total 40 Marks (Part A=16 Part B =24)	Short Answer questions (Part-A) Q. 1 = 4 marks Q. 2 to 5 = 3 Marks each Total=16 Marks	Long Answer Questions: (Part-B) Q. 6,7,8 @ 8 marks each ; Each question with Internal choice Total: 8X3 = 24 Marks

S.No. of the Question	Weightage of Marks	Language Skill / grammatical Concept of the question	Sub aspects & Description
S.No.	Marks allotted	Grammatical concept/ aspect/ skill	Sub topics / concepts
1	4 Marks (8 Questions X ½ Mark)	Vocabulary	a) Affixes, b) Synonyms c) antonyms d) one word substitutes
2	3 (6 Questions X ½ Mark)	Articles & Prepositions	a) Definite, indefinite articles b) Prepositions of place, time direction
3	3 (3 questions 1	Adjectives	a) Using appropriate forms of adjectives

	mark each)		b) Conversion of Degrees of comparison
4	3 (6 questions ½ mark each)	Helping Verbs	a) Primary helping verbs (be/do/have) b) Modal verbs
5	3 Marks (3 questions 1 mark each)	Phrasal verbs	Using phrasal verbs in sentences of one's own
6	8 Marks	Paragraph question A or B (internal choice)	Theme based questions : Lesson 1 : Focus on LSRW skills, problems and solutions in using English, Importance of English, English for employability, SWOC analysis
7	8	Dialogue making A or B (internal choice)	Conversation / Role play between two people : a) Dialogue on themes of lessons 2&3 b) Dialogue on General topic / a situation
8	8	Reading Comprehension A or B (internal choice)	Unseen prose passages with 8 different questions (F I V E model questions+ Others)
1	4Marks	Tenses	Present, Past, Future tenses : Filling in with proper verb forms using the given base form
2	3	Concord	Concord: agreement between subject and verb
3	3	Framing questions	Framing Wh & Yes-No questions
4	3	Types of sentences	Conversion of sentences (except questions) , Using of proper linkers / discourse markers
5	3 Marks	Words& Phrases , linkers	Using words& phrases, linkers in sentences of one's own
6	8 Marks	Paragraph writing A or B (internal choice)	a) Themes on lessons 4/5 b) Themes based on lessons 6/7
7	8	Letter Writing (internal choice : A or B)	a) Letter writing : formal b) Letter writing: Informal
8	8	a) Paragraph: Tenses Reinforcement b) Email & Instructions/ directions	a) Paragraph on Routines/ past narration / Future plans b) i) E- Mail writing (formal or informal) ii) Giving instructions/ directions
Part – A ; 16 Marks			
1	4 Marks	Error Analysis	Find errors and make corrections
2	3	Voice	Conversion: Active & Passive voice
3	3	Synthesis of sentence	Conversion: Simple, complex & compound sentences
4	3	Reported speech	Conversion: Direct & Indirect speech
5	3	Words & phrases, linkers	Matching words with their meanings/ Using words& phrases, linkers in sentences of one's own

Part- B : 8X3 = 24 Marks			
6	8 Marks	Essay writing A or B (internal choice)	a) Theme based (lessons 8 / 9) b) Theme based (Lessons 10/11)
7	8	Report writing A or B (internal choice)	a) Report on Mini projects/ industrial visits / camps/ events /exhibitions / celebrations b) themes from lessons 8 to 11 ...like disaster management / technical inventions / gender equality/ goal setting
8	8	Reading Comprehension A or B (internal choice)	Reading passages with 8 different questions (FIVE model+ others)

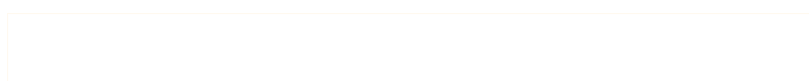

Model Question Papers : Unit Tests

Unit Test-1: C23- EC-101: English

Time: 90 Mnts.

Max. Marks: 40

Part-A

16 Marks

Instructions: Answer all the questions and the first question carries 3 marks. Question numbers from 2 to 5 carries three marks each. The marks will be awarded only for the desired and accurate language / grammatical expressions.

1. A) Give synonyms for the words: i) abruptly ii) advantage
B) Give antonyms for the words: i) pure ii) dry
C) Add affixes for the words: i) connect ii) worth
D) Give one word substitute for the following:
i) The interactive web page that can be updated frequently by an individual or group.
ii) An ability that can be acquired by anyone through practice.
2. A) Fill in the blanks with proper Articles:
i) My cousin joined M.Tech in _____ University in Tamil Nadu.
ii) Mrs. Rekha Chatterjee is _____ MLA from the West Bengal.
iii) My father came to _____ college yesterday to pay my exam fees.
B) Fill in with appropriate prepositions:
i) What can I do _____ you , Sarat?
ii) Mr. Agarwal distributed his property _____ his two daughters.
iii) The coach was pleased _____ the performance of the players.
3. a) Fill in with proper form of the adjective given in the brackets :
Burj Khalifa is one of _____ (tall) buildings in the world.
b) The tiger is more ferocious than the leopard. (Change into Positive degree)
c) Very few cities in India are as populous as Mumbai. (Change into comparative degree)
4. A) Fill in with proper Primary Helping Verbs (be/do/have forms)
i) Prasad _____ (be) at the canteen when I saw him a few minutes ago.
ii) He _____ (do) this work always.
iii) The teacher _____ just left the classroom.
B) Fill in with appropriate Modal verbs based on the clue given in the brackets:
i) We all _____ respect our elders. (moral obligation)
ii) Sir, _____ I come in please? (seeking permission)
iii) Tarun _____ easily win the match. (ability)
5. Use the following phrasal verbs in sentences of your own.
i) bring up ii) give away iii) put off

Part-B

8X3=24 Marks

Instructions: Answer all the questions. Each question carries 8 marks. The marks will be awarded for the appropriate content, quality and clarity of expressions, but not the length of your answer.

6. A) Write a paragraph in around 120 words about the significance of learning and using English in your present and future life.

OR

B) Write a paragraph in around 120 words about challenges you are facing in speaking and writing English and the solutions to overcome them.

7. A) Write a dialogue between two friends in at least six turns discussing the advantages and disadvantages of social media.

OR

B) Write a dialogue between two friends, who have joined different courses in different colleges after their tenth class and now exchanging information about their newly joined courses and colleges.

8. A) Read the following passage and answer the questions that follow. Your answer should be accurate, precise and limited to a word or phrase or a simple sentence:

Treating life as an adventure is the best quality of successful people. A person's security lies not in his comfort zone, but in his initiative, creativity and courage. Effective people do not label others from their past success or failure, but rediscover each time they meet them. These people are not overawed by top celebrities, cine personalities and sadhus. Winning people are excellent team players to take part in the process of creative problem solving. They are skillful at balancing their strengths and weaknesses with others. The final character of victorious people is exercising the four dimensions of life i.e., physical, mental, emotional, and enthusiastic.

Questions:

- a) What is the best quality of successful people?
- b) List out the three qualities which make a person secure?
- c) Why are the effective people not wondered at the lives of celebrities?
- d) What do the team players do?
- e) What is the special skill of the winning people?
- f) What is the final character of victorious people?
- g) What qualities of effective or winning people do you want to inculcate?
- h) Pick the word from the passage that would mean: "the feeling of respect, wonder and fear all together at something or someone"

OR

B) Read the following passage and answer the questions that follow. Your answer should be accurate, precise and limited to a word or phrase or a simple sentence:

Benjamin Franklin was born in 1706 in Boston, Massachusetts. He came from a big family. He had 16 brothers and sisters. When Benjamin was 15, his brother started the first Boston newspaper. It was called 'The New England Courant'. He worked for the newspaper for a short time, but he was not happy. So, he went to Philadelphia and worked as a printer. In 1729, he bought a newspaper business. The newspaper was the 'Pennsylvania Gazette'. He was very busy. In 1733, he started publishing 'Poor Richard's Almanac'. His pen name (the name he used as an author) was Richard Saunders. This book came out every year. Almanacs have information about weather and crops. They also have wise sayings. The wise saying "A penny saved is a penny earned" comes from Poor Richard's Almanac. Benjamin Franklin was also an inventor. In 1743 he invented a very good stove called the Franklin stove. He invented swim fins. He invented bifocal glasses. He also invented the first odometer. He retired from his newspaper business in 1749. He stopped working on it. Then he became busy with science. Benjamin Franklin was also very interested in American politics. He helped Thomas Jefferson write the Declaration of Independence. In 1776, he and other people signed the Declaration of Independence. Franklin died on April 17, 1790. He was 84 years old.

Questions:

- a) How many siblings did Benjamin Franklin have?

- b) What was the newspaper started by his brother?
- c) What did he buy after working as a printer?
- d) What information was available in his Almanacs?
- e) Mention any two inventions made by Benjamin Franklin?
- f) Rewrite the meaning of the saying in your own words: "A penny saved is a penny earned"
- g) Which American president was Benjamin Franklin associated with?
- h) Pick the word from the passage that would mean: "external limbs of fish that help them swim and steer".

-0o0-



Unit Test-2: C23- EC-101: English

Time: 90 Mnts.

Max. Marks: 40

Part-A

16 Marks

Instructions: Answer all the questions and the first question carries 4 marks. Question numbers from 2 to 5 carry Three marks each. The marks will be awarded only for the desired and accurate language / grammatical expressions.

1. Fill in with proper verb form using the base form given in the brackets.

- a) The match _____ (start) already before we entered the stadium.
- b) Rani _____ (clean) dishes when the phone rang.
- c) They _____ (hold) the thief tightly until the police arrived.
- d) Mr. Rajesh and his team _____(work) on this project since last month.

2. Fill in with the appropriate word from the pair given in the brackets.

- a) Bread and butter _____ a wholesome breakfast. (is / are)
- b) The minister accompanied by his staff _____ already arrived. (have/ has)
- c) Not only the film director but also all the actors _____ facilitated by the committee. (was/ were)

3. Frame two different 'Wh' questions and one 'Yes-No' question from the following:

India is the second most populous country just behind China. It is expected that in a few months, India stands top on the list due to our unprecedented birth rate. On the contrary, Japan is losing its population. The rate of death in Japan is double when compared to its birth rate of the country.

4. Convert the following sentences as directed.

- a) I want your bike for one hour. (convert into an imperative sentence)
- b) It is a very beautiful garden. (convert into an exclamatory sentence)
- c) Alas! what a great tragedy. (convert into a declarative sentence)

5. Use the following words/ phrases/ linkers in sentences of your own:

- a) struggle
- ii) ground breaking
- iii) however

Part-B

8X3=24 Marks

Instructions: Answer all the questions. Each question carries 8 marks. The marks will be awarded for the appropriate content, quality and clarity of expressions, but not the length of your answer.

6. A) Write a paragraph in around 120 words about dealing with obstacles and failures in one's life.

OR

B) Write a paragraph in around 120 words about protecting our environment.

7. A) Write a letter to your Principal requesting him / her to issue your Original Tenth marks list as you need to update your ADHAR card with date of birth and other details and return the certificate after the updating work.

OR

B) Write a letter to your father requesting him to send you two thousand rupees as you have to pay your hostel fees.

8. A) Write a paragraph in around 120 words about your future plans after Diploma.

OR

B) i) Draft an E-mail to your friend inviting him/her to your village to spend the weekend with you.

ii) Write a set of instructions at least in five sentences about drawing money from an ATM.

-0o0-



Unit Test-3: C23- Common-101: English

Time: 90 Mnts.

Max. Marks: 40

Part-A

16 Marks

Instructions: Answer all the questions and the first question carries 4 marks. Question numbers 2 to 5 carry Three marks each. The marks will be awarded only for the desired and accurate language / grammatical expressions.

1. Correct the following sentences:
 - a) All the books have been sold out last week.
 - b) I, Ramesh and you will together book a cab.
 - c) I am feeling terribly cold.
 - d) The police has arrested the gang of robbers.
2. Change the voice of the following:
 - a) A cat is chasing two rats.
 - b) The news has been published recently.
 - c) They will certainly win the match.
3. Rewrite the sentences as directed:
 - a) Though Rakesh studied well, he could not get the first class. (Convert into a simple sentence)
 - b) It was raining heavily, and so the match was cancelled. (Convert into a complex sentence)
 - c) The horse was too old to gallop. (Convert into a compound sentence)
4. Change the speech of the following as directed:
 - a) Satwik said to his mother, "I forgot my water bottle in my classroom."
 - b) The teacher ordered the students not to make noise.
 - c) Swapna said, "Rajesh, what are you searching for?"
5. Use the following words /phrases/ linkers in sentences of your own:
 - i) apologize to
 - ii) occasionally
 - iii) for a while

Part-B

8X3=24 Marks

Instructions: Answer all the questions. Each question carries 8 marks. The marks will be awarded for the appropriate content, quality and clarity of expressions, but not the length of your answer.

6. A) Write an essay in around 180 words on how the technical inventions changed our lives.

OR

- B) Write an essay in around 180 words about the significance of the gender equality.

- 7 A) Write a report about any disaster that you have read in newspaper or witnessed including your suggestions for better preventive measures to mitigate the loss.

OR

- B) Write a report about the Inter Polytechnics Sports and Games Meet (IPSGM) held in your District headquarters.

- 8 A) Read the following passage and answer the questions that follow. Your answer should be accurate, precise and limited to a word or phrase or a simple sentence.

Animals living in modern zoos enjoy several advantages over animals in the wild; however, they must also suffer some disadvantages. One advantage of living in the zoo is that the animals are separated from their natural predators; they are protected and can, therefore, live without

risk of being attacked. Another advantage is that they are regularly fed a special, well-balanced diet; thus, they do not have to hunt for food or suffer times when food is hard to find. On the other hand, zoo animals face several disadvantages. The most important disadvantage is that since they do not have to hunt for food or face their enemies, some animals became bored, discontented or even nervous. Another disadvantage is that zoo visitors can endanger their lives. Some animals can pick up airborne diseases from humans.

Questions:

- a) What are the two animal habitations mentioned in the passage?
- b) Give the main advantage of animals living in zoo.
- c) What kind of food is the zoo animals fed with?
- d) What is the most disadvantage aspect faced by the zoo animals?
- e) How do you think that the visitors can harm the zoo animals?
- f) Do you support keeping the animals in a zoo for our entertainment? Justify your answer in a sentence.
- g) Pick the word from the passage that would mean: A violent or bigger animal that kills and eats the other tiny animal.
- h) Suggest a suitable title for the passage.

OR

- B) Read the following passage and answer the questions that follow. Your answer should be accurate, precise and limited to a word or phrase or a simple sentence.

“I say to you today, my friends, even though we face the difficulties’ of today and tomorrow, I still have a dream. I have a dream that one day this nation will rise up, live out the true meaning of its creed. I have a dream that one day on the red hills of Georgia sons of former slaves and sons of former slave-owners will be able to sit down together at the table of brotherhood. I have a dream that my four little children will one day live in a nation where they will not be judged by the colour of their skin but by the content of their character. I have a dream.... I have a dream that one day in Alabama, with its vicious racists, with its governor having his lips dripping with the words of interposition and nullification, one day right there in Alabama little black boys and black girls will be able to join hands with little white boys and white girls as sisters and brothers:” On 28th August in 1963, Dr. Martin Luther King, Jr. spoke these immortal words to a crowd of over 200000 people who had gathered for the now historic march in Washington to demand an end to racial segregation in the USA, and for equality in jobs and civil rights.

Questions:

- a) Who is the speaker of the above speech and what is his nationality?
- b) What is the occasion of the above speech: ()
 - i) a birthday party
 - ii) an election campaign
 - iii) a movement for a right cause
 - iv) a government function
- c) What sort of discrimination did the speaker fight against?
- d) What good does he expect regarding the children of slaves and masters?
- e) What is the contextual meaning of the frequently used word “dream” ?
- f) How should a nation be judged?
- g) What are the two places mentioned by the speaker in his speech?
- h) Pick the word from the passage that would mean: “that lives for ever without death”

-0o0-



C-23 - ENGINEERING MATHEMATICS-I

Course Code	Course Title	No. of Periods/week	Total No. of periods	Marks for FA	Marks for SA
EC-102	Engineering Mathematics-I	5	150	20	80

S.No.	Unit Title	No. of periods	COs mapped
1	Algebra	31	CO1
2	Trigonometry	44	CO2
3	Co-ordinate Geometry	23	CO3
4	Differential Calculus	34	CO4
5	Applications of Derivatives	18	CO5
Total Periods		150	

Course Objectives	<ul style="list-style-type: none"> (i) To apply the principles of Algebra, Trigonometry and Co-Ordinate Geometry to real-time problems in engineering. (ii) To comprehend and apply the concept of Differential Calculus in engineering applications.
--------------------------	---

Course Outcomes	CO1	Identify functions as special relations, resolve partial fractions and solve problems on matrices and determinants.
	CO2	Solve problems using the concept of trigonometric functions, their inverses and complex numbers.
	CO3	Find the equations and properties of straight lines, circles and conic sections in coordinate system.
	CO4	Evaluate the limits and derivatives of various functions
	CO5	Find solutions for engineering problems using differentiation.

Learning Outcomes:

UNIT - I

C.O. 1 Identify functions, resolve partial fractions and solve problems on matrices and determinants.

- L.O.**
- 1.1 Define Set, ordered pair and Cartesian product of two sets - examples.
 - 1.2 Explain Relations and functions – examples
 - 1.3 Find Domain & Range of functions in finite sets – simple examples.
 - 1.4 Define rational, proper and improper fractions of polynomials.
 - 1.5 Explain the procedure of resolving proper fractions of the types mentioned below into partial fractions

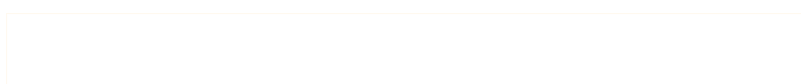

$$i) \frac{f(x)}{(ax+b)(cx+d)} \quad ii) \frac{f(x)}{(ax+b)^2(cx+d)}$$

- 1.6 Define a matrix and order of a matrix.
- 1.7 State various types of matrices with examples (emphasis on 3rd order square matrices).
- 1.8 Compute sum, difference, scalar multiplication and product of matrices. Illustrate the properties of these operations such as associative, distributive, commutative properties with examples and counter examples.
- 1.9 Define the transpose of a matrix and state its properties – examples.
- 1.10 Define symmetric and skew-symmetric matrices with examples. Resolve a square matrix into a sum of symmetric and skew-symmetric matrices and provide examples.
- 1.11 Define determinant of a square matrix; minor, co-factor of an element of a 3x3 square matrix with examples. Expand the determinant of a 3 x 3 matrix using Laplace expansion formula. State and apply the properties of determinants to solve problems.
- 1.12 Distinguish singular and non-singular matrices. Define multiplicative inverse of a matrix and list properties of adjoint and inverse. Compute adjoint and multiplicative inverse of a square matrix.
- 1.13 Solve system of 3 linear equations in 3 unknowns using Cramer's rule and matrix inversion method.

UNIT - II

C.O. 2 Solve problems using the concept of trigonometric functions, their inverses and complex numbers.

- L.O.**
- 2.1 Define trigonometric ratios of any angle - List the values of trigonometric ratios at specified values.
 - 2.2 Draw graphs of trigonometric functions - Explain periodicity of trigonometric functions.
 - 2.3 Define compound angles and state the formulae of $\sin(A\pm B)$, $\cos(A\pm B)$, $\tan(A\pm B)$ and $\cot(A\pm B)$.
 - 2.4 Give simple examples on compound angles to derive the values of $\sin 15^\circ$, $\cos 15^\circ$, $\sin 75^\circ$, $\cos 75^\circ$, $\tan 15^\circ$, $\tan 75^\circ$ etc.
 - 2.5 Derive identities like $\sin(A+B) \sin(A-B) = \sin^2 A - \sin^2 B$ etc.
 - 2.6 Solve simple problems on compound angles.
 - 2.7 Derive the formulae of multiple angles $2A$, $3A$ etc and sub multiple angles $A/2$ in terms of angle A of trigonometric functions.
 - 2.8 Derive useful allied formulae like $\sin^2 A = (1 - \cos 2A)/2$ etc.
 - 2.9 Solve simple problems using the above formulae
- Syllabus for Unit test-I completed
- 2.10 Derive the formulae on transforming sum or difference of two trigonometric ratios into a product and vice versa, examples on these formulae.
 - 2.11 Solve problems by applying these formulae to sum or difference or product of two terms.
 - 2.12 Explain the concept of the inverse of a trigonometric function by selecting an appropriate domain and range.
 - 2.13 Define inverses of six trigonometric functions along with their domains and ranges.



- 2.14 Derive relations between inverse trigonometric functions so that the given inverse trigonometric function can be expressed in terms of other inverse trigonometric functions with examples.
- 2.15 State various properties of inverse trigonometric functions and identities like $\sin^{-1}x + \cos^{-1}x = \frac{\pi}{2}$, etc.
- 2.16 Apply formulae like $\tan^{-1}x + \tan^{-1}y = \tan^{-1}\left(\frac{x+y}{1-xy}\right)$, where $x \geq 0, y \geq 0, xy < 1$ etc., to solve Simple problems.
- 2.17 Explain what is meant by solution of trigonometric equations and find the general solutions of $\sin x = k$, $\cos x = k$ and $\tan x = k$ with appropriate examples.
- 2.18 Solve models of the type $a \sin^2 x + b \sin x + c = 0$ and $a \cos x + b \sin x = c$.
- 2.19 State sine rule, cosine rule, tangent rule and projection rule and solve a triangle using these formulae.
- 2.20 List various formulae for the area of a triangle with examples.
- 2.21 Define complex number, its modulus, conjugate, amplitude and list their properties.
- 2.22 Define the operations on complex numbers with examples.
- 2.23 Represent the complex number in various forms like modulus-amplitude (polar) form, Exponential (Euler) form with examples.

UNIT - III

Coordinate Geometry

C.O. 3 Find the equations and properties of straight lines, circles and conic sections in coordinate system.

- L.O.3.1 Write the different forms of a straight line – general form, point-slope form, slope-intercept form, two-point form, intercept form and normal form (or perpendicular form).
- 3.2 Find distance of a point from a line, acute angle between two lines, intersection of two non-parallel lines and distance between two parallel lines.
- 3.3 Define locus of a point and circle.
- 3.4 Write the general equation of a circle and find the centre and radius.
- 3.5 Find the equation of a circle given (i) centre and radius, (ii) two ends of the diameter (iii) three non collinear points of type (0,0) (a,0), (0,b).
- 3.6 Define a conic section - Explain the terms focus, directrix, eccentricity, axes and latus-rectum of a conic with illustrations.
- 3.7 Find the equation of a conic when focus, directrix and eccentricity are given.
- 3.8 Describe the properties of Parabola, Ellipse and Hyperbola in standard forms whose axes are along the co-ordinate axes and solve simple examples on these conics.

Syllabus for Unit test-II completed

C.O.4 Evaluate the limits and derivatives of various functions.

- L.O. 4.1 Explain the concept of limit and meaning of $\lim_{x \rightarrow a} f(x) = l$ and state the properties of limits.



4.2 Evaluate the limits of the type $\lim_{x \rightarrow l} \frac{f(x)}{g(x)}$ and $\lim_{x \rightarrow \infty} \frac{f(x)}{g(x)}$

4.3 State the Standard limits $\lim_{x \rightarrow a} \frac{x^n - a^n}{x - a}$, $\lim_{x \rightarrow 0} \frac{\sin x}{x}$, $\lim_{x \rightarrow 0} \frac{\tan x}{x}$, $\lim_{x \rightarrow 0} \frac{a^x - 1}{x}$, $\lim_{x \rightarrow 0} \frac{e^x - 1}{x}$, $\lim_{x \rightarrow 0} (1+x)^{\frac{1}{x}}$, $\lim_{x \rightarrow \infty} \left(1 + \frac{1}{x}\right)^x$ (without proof) and solve simple problems using these standard limits.

4.4 Explain the concept of continuity of a function at a point and on an interval

4.5 State the concept of derivative of a function $y = f(x)$ – definition, first principle as $\lim_{h \rightarrow 0} \frac{f(x+h) - f(x)}{h}$ and also provide standard notations to denote the derivative of a function.

4.6 Explain the significance of derivative in scientific and engineering applications.

4.7 Find the derivative of the elementary functions x^n , a^x , e^x , $\log x$, $\sin x$, $\cos x$ using the first principle.

4.8 Find the derivatives of standard algebraic, logarithmic and exponential functions.

4.9 Find the derivatives of trigonometric, inverse trigonometric and hyperbolic functions.

4.10 State the rules of differentiation of sum, difference, scalar multiplication, product and quotient of functions with simple illustrative examples.

4.11 Explain the method of differentiation of a function of a function (Chain rule) with illustrative examples.

4.12 Explain the method of differentiation of parametric functions with examples.

4.13 Explain the procedure for finding the derivatives of implicit functions with examples.

4.14 Explain the need of taking logarithms for differentiating some functions of $[f(x)]^{g(x)}$ type – examples on logarithmic differentiation.

4.15 Explain the concept of finding the second order derivatives with examples.

4.16 Explain the concept of functions of several variables, finding partial derivatives and difference between the ordinary and partial derivatives with simple examples.

4.17 Explain the concept of finding second order partial derivatives with simple problems.

C.O. 5 Evaluate solutions for engineering problems using differentiation

- L.O.**
- 5.1 State the geometrical meaning of the derivative - Explain the concept of derivative to find the slopes of tangent and normal to the curve $y=f(x)$ at any point on it.
 - 5.2 Find the equations of tangent and normal to the curve $y=f(x)$ at any point on it – examples.
 - 5.3 Explain the derivative as a rate of change in distance-time relations to find the velocity and acceleration of a moving particle with examples.
 - 5.4 Explain the derivative as a rate measurer in the problems where the quantities like volumes, areas vary with respect to time- illustrative examples.
 - 5.5 Define the concept of increasing and decreasing functions - Explain the conditions to find points where the given function is increasing or decreasing with illustrative examples.
 - 5.6 Explain the procedure to find the extreme values (maxima or minima) of a function of single variable- simple problems for quadratic and cubic polynomials.
 - 5.7 Apply the concept of derivatives to find the errors and approximations in simple problems.

Syllabus for Unit test-III completed

CO/PO – Mapping

	PO1	PO2	PO3	PO4	PO5	PO6	PO7	PSO1	PSO2	PSO3
CO1	3	2	1	2				3	2	3
CO2	3	3	3	2				3	3	1
CO3	3	2	2	1				3	2	2
CO4	3	3	2	2				3	2	1
CO5	3	3	3	3				3	3	3
Avg.	3	2.6	2.2	2				3	2.4	2

3 = Strongly mapped (High), **2** = moderately mapped (Medium), **1** = slightly mapped (Low)

Note:

PO5: Appropriate quiz programme may be conducted at intervals and duration as decided by concerned teacher.

PO6: Seminars on applications of mathematics in various engineering disciplines are to be planned and conducted.

PO7: Such activities are to be planned that students visit library to refer standard books on Mathematics and latest updates in reputed national and international journals, attending seminars, learning mathematical software tools.

PO- CO – Mapping strength

PO No	Mapped with CO no	CO periods addressing PO in column I		Level (1,2 or 3)	Remarks
		No	%		
1	CO1, CO2, CO3,CO4,CO5	150	100%	3	>40% Level 3 Highly addressed 25% to 40% Level 2 Moderately addressed 5% to 25% Level 1 Low addressed <5% Not addressed
2	CO1, CO2, CO3,CO4,CO5	138	92%	3	
3	CO1, CO2, CO3,CO4,CO5	133	88.6%	3	
4	CO1, CO2, CO3,CO4,CO5	120	80%	3	
PSO 1	CO1, CO2, CO3,CO4,CO5	150	100%	3	
PSO 2	CO1, CO2, CO3,CO4,CO5	135	90%	3	
PSO 3	CO1, CO2, CO3,CO4,CO5	125	83.3%	3	

COURSE CONTENT

Unit-I Algebra

1. Functions:

Definitions of Set, Ordered pair, Cartesian product of two sets, Relations, functions, domain & range of functions in finite sets.

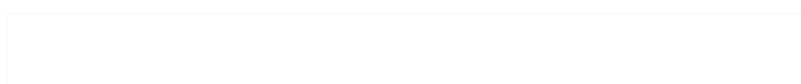

2. Partial Fractions:

Definitions of rational, proper and improper fractions of polynomials. Resolve rational fractions (proper fractions) in to their partial fractions covering the types mentioned below.

$$i) \frac{f(x)}{(ax+b)(cx+d)}$$

$$ii) \frac{f(x)}{(ax+b)^2(cx+d)}$$

3. Matrices:

Definition of a matrix, types of matrices-examples, algebra of matrices-equality of two matrices, sum, difference, scalar multiplication and product of matrices. Transpose of a matrix-Symmetric, skew symmetric matrices-Minor, cofactor of an element-Determinant of a square matrix-Laplace's expansion, properties of determinants. Singular and non-singular matrices-Adjoint and multiplicative inverse of a square matrix- examples-System of linear equations in 3 variables-Solutions by Cramer's rule and Matrix inversion method-examples.

Unit-II Trigonometry

4. Trigonometric ratios:

Definition of trigonometric ratios of any angle, values of trigonometric ratios at specified values, draw graphs of trigonometric functions, periodicity of trigonometric functions.

5. Compound angles:

Formulas of $\sin(A\pm B)$, $\cos(A\pm B)$, $\tan(A\pm B)$, $\cot(A\pm B)$, and related identities with problems.

6. Multiple and sub multiple angles:

Formulae for trigonometric ratios of multiple angles $2A$, $3A$ and sub multiple angles $A/2$ with problems.

7. Transformations: Transformations of products into sums or differences and vice versa - simple problems.

8. Inverse trigonometric functions:

Definition, domains and ranges-basic properties- problems.

9. Trigonometric equations:

Concept of a solution, principal value and general solution of trigonometric equations: $\sin x = k$, $\cos x = k$, $\tan x = k$, where k is a constant. Solutions of simple quadratic equations and equations of type $a \cos x + b \sin x = c$.

10. Properties of triangles:

Relation between sides and angles of a triangle- sine rule, cosine rule, tangent rule and projection rule-area of a triangle- problems.

11. Complex Numbers:

Definition of a complex number, Modulus, conjugate and amplitude of a complex number, Arithmetic operations on complex numbers, Modulus- Amplitude (polar) form, Exponential form (Euler form) of a complex number- Problems.

UNIT-III

Coordinate geometry

12. Straight lines: various forms of straight lines, angle between lines, perpendicular distance from a point, intersection of non-parallel lines and distance between parallel lines-examples.

13. Circle: locus of a point, Circle, definition-Circle equation given (i) centre and radius, (ii) two ends of a diameter (iii) three non collinear points of type $(0,0)$, $(a,0)$, $(0,b)$ - general equation of a circle - finding centre, radius.



14. Definition of a conic section, equation of a conic when focus directrix and eccentricity are given. Properties of parabola, ellipse and hyperbola in standard forms.

UNIT-IV

Differential Calculus

15. **Concept of Limit-** Definition and Properties of Limits and Standard Limits -Simple Problems- Continuity of a function at a point- Simple Examples only.
16. **Concept of derivative-** Definition (first principle)- different notations-derivatives of elementary functions. Derivatives of algebraic, logarithmic, trigonometric, inverse trigonometric and hyperbolic functions. Derivatives of sum, product, quotient, scalar multiplication of functions - problems. Chain rule, derivatives of parametric functions, derivatives of implicit functions, logarithmic differentiation – problems in each case. Second order derivatives – examples. Functions of several variables –First and second order partial differentiation-simple problems.

UNIT-V

Applications of Derivatives

17. Geometrical meaning of the derivative, equations of tangent and normal to a curve at any point - problems.
18. Physical applications of derivatives – velocity, acceleration, derivative as a rate measure –Problems.
19. Applications of the derivative to find the extreme values – Increasing and decreasing functions, finding the maxima and minima for quadratic and cubic polynomials.
20. Using the concept of derivative of a function of single variable, find the absolute error, relative and percentage errors and approximate values due to errors in measuring.

Textbook:

Engineering Mathematics-I, a textbook for first year diploma courses, prepared & prescribed by SBTET, AP.

Reference Books:

1. Shanti Narayan, A Textbook of matrices, S.Chand&Co.
2. Robert E. Moyer & Frank Ayers Jr., Schaum's Outline of Trigonometry, 4th Edition, Schaum's Series.
3. M.Vygodsky, Mathematical Handbook, Mir Publishers, Moscow.
4. Frank Ayers & Elliott Mendelson, Schaum's Outline of Calculus, Schaum's Series.

Blue print

S.No.	Chapter/Unit title	No. of Periods	Weightage Allotted	Short type			Essay type			COs mapped
				R	U	Ap	R	U	Ap	
Unit - I : Algebra										
1	Functions	5	3	1	0	0	0	0	0	CO1
2	Partial Fractions	6	3	1	0	0	0	0	0	CO1
3	Matrices and Determinants	20	16	2	0	0	0	0	1	CO1
Unit - II : Trigonometry										
4	Trigonometric Ratios	2	0	0	0	0	0	0	0	CO2
5	Compound Angles	5	3	1	0	0	0	0	0	CO2
6	Multiple and Submultiple angles	8	3	1	0	0	0	0	0	CO2

7	Transformations	6	5	0	0	0	0	1/2	0	CO2
8	Inverse Trigonometric Functions	6	5	0	0	0	0	1/2	0	CO2
9	Trigonometric Equations	6	5	0	0	0	0	1/2	0	CO2
10	Properties of triangles	5	5	0	0	0	0	0	1/2	CO2
11	Complex Numbers	6	3	1	0	0	0	0	0	CO2
Unit III : Co-ordinate Geometry										
12	Straight Lines	6	5	0	0	0	0	1/2	0	CO3
13	Circles	5	3	1	0	0	0	0	0	CO3
14	Conic Sections	12	5	0	0	0	0	1/2	0	CO3
Unit – IV : Differential Calculus										
15	Limits and Continuity	6	6	1	1	0	0	0	0	CO4
16	Differentiation	28	20	0	0	0	1	1	0	CO4
Unit – V : Applications of Derivatives										
17	Geometrical Applications	4	5	0	0	0	0	0	1/2	CO5
18	Physical Applications	6	5	0	0	0	0	0	1/2	CO5
19	Maxima and Minima	4	5	0	0	0	0	0	1/2	CO5
20	Errors and Approximations	4	5	0	0	0	0	0	1/2	CO5
Total		150	110	9	1	0	1	3 1/2	3 1/2	
Marks				27	3	0	10	35	35	

R: Remembering Type : 37 Marks

U: understanding Type : 38 Marks

Ap: Application Type : 35 Marks

Unit Test Syllabus

Unit Test	Syllabus
Unit Test-I	From L.O. 1.1 to L.O. 2.9
Unit Test-II	From L.O. 2.10 to L.O. 3.8
Unit Test-III	From L.O.4.1 to L.O. 5.7

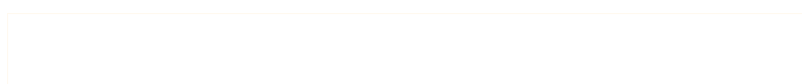

Unit Test I
State Board of Technical Education and Training, A. P.
First Year
Subject name: Engineering Mathematics-I
Sub Code: EC-102

C-23, EC -102

Time : 90 minutes

Max.marks:40

Part-A

16Marks

Instructions: (1) Answer all questions.
(2) First question carries four marks and the remaining questions carry Three marks each.

1. Answer the following:
 - a. If $X = \{1, 2, 3, 4\}$ and $Y = \{1, 4, 9, 16, 25\}$, then $f : X \rightarrow Y$ defined by $f = \{(1,1), (2,4), (3,9), (4,16)\}$ is a function: State TRUE/FALSE. (CO1)
 - b. If $A = \begin{bmatrix} 1 & 2 \\ 3 & 4 \end{bmatrix}$, then $3A =$ _____. (CO1)
 - c. The value of $\sin 45^\circ + \cos 45^\circ$ is _____. (CO2)
 - d. The formula for $\tan 2A$ in terms of $\tan A$ is _____. (CO2)
2. If $A = \begin{bmatrix} 1 & 3 \\ 4 & -9 \end{bmatrix}$, $B = \begin{bmatrix} 2 & 4 \\ -3 & 1 \end{bmatrix}$ then find $A + B$. (CO1)
3. Find the determinant of $\begin{bmatrix} 2 & -1 & 4 \\ 0 & -2 & 5 \\ -3 & 1 & 3 \end{bmatrix}$. (CO1)
4. Find the value of $\sin 75^\circ$. (CO2)
5. Prove that $\frac{\sin 2A}{1 - \cos 2A} = \cot A$ (CO2)

Part-B

3×8=24

Instructions: (1) Answer all questions.
(2) Each question carries eight marks
(3) Answer should be comprehensive and the criterion for valuation is the content but not the length of the answer.

6. A) Resolve $\frac{2x}{(x-1)(x-3)}$ into partial fractions. (CO1)
or
B) Resolve $\frac{x-4}{(x-2)(x-3)}$ into partial fractions. (CO1)
7. A) If $A = \begin{bmatrix} 2 & 3 & 4 \\ 5 & 7 & 9 \\ -2 & 1 & 3 \end{bmatrix}$ and $B = \begin{bmatrix} 3 & 1 & -5 \\ 2 & 1 & 4 \\ 0 & 3 & 1 \end{bmatrix}$, then find AB (CO1)

Or

B) If $P = \begin{bmatrix} 3 & 1 & 4 \\ 1 & -2 & 0 \\ 3 & 1 & 6 \end{bmatrix}$ and $Q = \begin{bmatrix} 1 & 5 & -3 \\ 0 & 6 & 9 \\ -2 & 7 & 8 \end{bmatrix}$, show that $(P+Q)^T = P^T + Q^T$.
(CO1)

8. A) Find the adjoint of the matrix $\begin{bmatrix} 1 & 2 & -2 \\ -1 & 3 & 5 \\ 2 & 7 & -4 \end{bmatrix}$ (CO1)

or

B) Solve the following system of linear equations by Cramer's rule:
 $x - y + z = 2, 2x + 3y - 4z = -4, 3x + y + z = 8$ (CO1)
 -o0o-

Unit Test II
State Board of Technical Education and Training, A. P.
First Year
Subject name: Engineering Mathematics-I
Sub Code: EC- 102

C -23, EC -102

Time : 90 minutes

Max.marks:40

Part-A

16Marks

Instructions: (1) Answer all questions.
 (2) First question carries four marks and the remaining questions carry threemarks each

1. Answer the following.

a. $\sin C + \sin D = 2 \cos\left(\frac{C+D}{2}\right) \sin\left(\frac{C-D}{2}\right)$: State TRUE/FALSE (CO2)

b. If $\sin^{-1}\left(\frac{3}{5}\right) = \tan^{-1}(x)$, then $x =$ _____ (CO2)

c. If $z = 2 + 3i$, then $|z| =$ _____ (CO2)

d. The eccentricity of the rectangular hyperbola is _____ (CO3)

2. Express $(3 - 4i)(7 + 2i)$ in terms of $a + ib$ (CO2)

3. Find the intercepts made by the straight line $x + 5y - 10 = 0$. (CO3)

4. Find the centre and radius of the circle $x^2 + y^2 - 2x + 4y - 4 = 0$ (CO3)

5. Find the vertex and focus of the parabola $y^2 = 8x$. (CO3)

Part-B

3×8=24

Instructions: (1) Answer all questions.
(2) Each question carries eight marks
(3) Answer should be comprehensive and the criterion for valuation is the content but not the length of the answer.

6. A) Prove that $\frac{\sin 5\theta + \sin \theta}{\cos 5\theta + \cos \theta} = \tan 3\theta$. (CO2)
or
B) Prove that $\tan^{-1}\left(\frac{1}{4}\right) + \tan^{-1}\left(\frac{3}{5}\right) = \frac{\pi}{4}$ (CO2)
7. A) Solve $2\sin^2 \theta - \sin \theta - 1 = 0$ (CO2)
or
B) If $a=3, b=4, c=5$, find the area of the ΔABC . (CO2)
8. A) Find the equation of the line passing through (1,1) and perpendicular to the line $2x + 3y - 1 = 0$. Also find the perpendicular distance from the given point to the given line. (CO3)
or
B) Find the equation of the ellipse whose focus is (2, 0), directrix is $x+y-1=0$ and eccentricity is $\frac{1}{2}$. (CO3)

-o0o-



Unit Test III
State Board of Technical Education and Training, A. P
First Year
Subject name: Engineering Mathematics-I
Sub Code: EC-102

C –23, EC -102

Time : 90 minutes

Max.Marks:40

Part-A

16 Marks

Instructions: (1) Answer all questions.

(2) First question carries four marks and the remaining questions carry threemarks each.

1. Answer the following:

a. $\lim_{x \rightarrow 1} \frac{x^2 + 1}{x + 5} = \frac{1}{3}$: State TRUE/FALSE. (CO4)

b. $\frac{d}{dx}(x^n) = \underline{\hspace{2cm}}$ (CO4)

c. $\frac{d}{dx}(3 \tan^{-1} x) = ?$ (CO4)

d. Write the formula for finding the percentage error in x. (CO5)

2. Evaluate $\lim_{\theta \rightarrow 0} \frac{\sin 2\theta}{\theta}$ (CO4)

3. Find the derivative of $3 \tan x + 4 \log x$ w.r.t. x. (CO4)

4. Differentiate $x^2 \sin x$ w.r.t. x. (CO4)

5. Find the slope of the tangent to the curve $y = x^3 - 3x + 2$ at the point (1, 7). (CO5)

Part-B

3×8=24

Instructions: (1) Answer all questions.

(2) Each question carries eight marks

(3) Answer should be comprehensive and the criterion for valuation is the content but not the length of the answer.

6. A) if $x = at^2$ and $y = 2at$ then find $\frac{dy}{dx}$ (CO4)
or

B) Find $\frac{dy}{dx}$, if $y = x^x$ (CO4)

7. A) If $y = ae^x + be^{-x}$, then prove that $\frac{d^2y}{dx^2} - y = 0$. (CO4)

or

B) If $u(x, y) = \log(x + y)$, then find $\frac{\partial u}{\partial x}$ and $\frac{\partial u}{\partial y}$ (CO4)

8. A) The radius of a sphere is decreasing at a rate of 0.2 cm/sec. How fast is its surface area decreasing when the radius is 10 cm. (CO5)

or

B) Find the maximum and minimum values of the function $f(x) = x^3 - 3x$. (CO5)

-o0o-



END-EXAM MODEL PAPERS
STATE BOARD OF TECHNICAL EDUCATION, A.P
C-23 ENGINEERING MATHEMATICS-I, EC- 102

TIME : 3 HOURS

MODEL PAPER- I

MAX.MARKS : 80M

PART-A

Answer All questions. Each question carries THREE marks.

10x3=30M

1. If $A = \left\{0, \frac{\pi}{4}, \frac{\pi}{2}\right\}$ and $f : A \rightarrow B$ is a function defined by $f(x) = \cos x$, then find the range of f . (CO1)
2. Resolve the function $\frac{x}{(x-1)(x-2)}$ into partial fractions. (CO1)
3. If $A = \begin{bmatrix} 3 & 9 & 0 \\ 1 & 8 & -2 \end{bmatrix}$ and $B = \begin{bmatrix} 4 & 0 & 2 \\ 7 & 1 & 4 \end{bmatrix}$, find $A+B$ (CO1)
4. Find the determinant of the matrix $\begin{bmatrix} 2 & -1 & 4 \\ 0 & -2 & 5 \\ -3 & 1 & 3 \end{bmatrix}$ by Laplace's expansion. (CO1)
5. Show that $\frac{\cos 16^\circ + \sin 16^\circ}{\cos 16^\circ - \sin 16^\circ} = \tan 61^\circ$. (CO2)
6. Prove that $\frac{\sin 2\theta}{1 - \cos 2\theta} = \cot \theta$. (CO2)
7. Find the modulus of the complex number $3 + 4i$. (CO2)
8. Find the equation of the circle with centre (0, 0) and radius 5. (CO3)
9. Evaluate $\lim_{x \rightarrow 0} \frac{2x^2 - 3x + 1}{x^2 - 2x + 4}$. (CO4)
10. Find $\lim_{x \rightarrow 0} \frac{\sin 77x}{\sin 11x}$. (CO4)

PART-B

Answer any FIVE questions. Each question carries TEN marks.

5x10=50M

11. Solve the system of linear equations $x + y + z = 6$, $x - y + z = 2$ and $2x + y - z = 1$ using matrix inversion method. (CO1)
12. A) Show that $\frac{\sin 7\theta + \sin 5\theta}{\cos 7\theta + \cos 5\theta} = \tan 6\theta$. (CO2)
B) Prove that $\tan^{-1}\left(\frac{1}{7}\right) + \tan^{-1}\left(\frac{1}{13}\right) = \tan^{-1}\left(\frac{2}{9}\right)$ (CO2)
13. A) Solve $(2 \sin x - 1)(\tan x - \sqrt{3}) = 0$. (CO2)
B) If $a = 10$, $b = 12$, $c = 5$, then find the area of the ΔABC . (CO2)



14. A) Find the distance between the parallel lines $4x - 3y + 9 = 0$ and $4x - 3y + 5 = 0$. Also find their slopes. (CO3)
- B) Find the equation of the conic whose focus is $(1,0)$, directrix is $3x+4y+1=0$ and eccentricity is 2. (CO3)
15. A) Find the derivative of $3\tan x - 4\log x - 7x^2 + \sqrt{x}$ w.r.t x . (CO4)
- B) Find the derivative of x^2e^{3x} w.r.t x . (CO4)
16. A) If $x = a(1 - \cos \theta)$, $y = a(\theta + \sin \theta)$, then find $\frac{dy}{dx}$. (CO4)
- B) If $u(x, y) = x^2y + y^2x$, then find $\frac{\partial u}{\partial x}$ and $\frac{\partial u}{\partial y}$ (CO4)
17. A) Find the equation of tangent to the curve $y = x^2 + 1$ at $(2,1)$. (CO5)
- B) The radius of a circular plate is increasing at 0.7 cm/sec. What is the rate of increase in its area when radius is 10 cm? (CO5)
18. A) Find maximum or minimum value of $f(x) = x^2 - 4x + 3$. (CO5)
- B) If an error of 0.02 cm is made in the side of a square, what is the approximate error in the area and perimeter of the square? (CO5)

-o0o-



STATE BOARD OF TECHNICAL EDUCATION, A.P.
C-23 ENGINEERING MATHEMATICS-I, EC- 102

TIME : 3 HOURS

MODEL PAPER- II

MAX.MARKS : 80M

PART-A

Answer All questions. Each question carries THREE marks.

10x3=30M

1. If $A = \{-1, 0, 1\}$ and $f: A \rightarrow B$ is defined by $f(x) = x^2 - x + 1$, then find the range of f .
(CO1)
2. Resolve the function $\frac{1}{(x+1)(x-2)}$ into partial fractions. (CO1)
3. If $A = \begin{bmatrix} 3 & 9 & 0 \\ 1 & 8 & -2 \end{bmatrix}$ and $B = \begin{bmatrix} 4 & 0 & 2 \\ 7 & 1 & 4 \end{bmatrix}$, then find $(A+B)^T$. (CO1)
4. If $A = \begin{bmatrix} 4 & 2 \\ -1 & 1 \end{bmatrix}$, then find A^2 . (CO1)
5. Find the value of $\frac{\cos 36^\circ + \sin 36^\circ}{\cos 36^\circ - \sin 36^\circ} = \tan 81^\circ$. (CO2)
6. Prove that $\frac{1 + \cos 2\theta}{\sin 2\theta} = \cot \theta$. (CO2)
7. Find the modulus of the complex number $3+2i$. (CO2)
8. Find the equation of the circle with centre $(1,2)$ and radius 4. (CO3)
9. Find $\lim_{x \rightarrow 0} \frac{2x^2 - 3x + 1}{x^2 - 2x + 4}$. (CO4)
10. Find $\lim_{x \rightarrow 0} \frac{\sin 5x}{\tan 3x}$. (CO4)

PART-B

Answer any FIVE questions. Each question carries TEN marks.

5x10=50M

11. Solve the system of linear equations $x - y + 3z = 5$, $4x + 2y - z = 0$ and $-x + 3y + z = 5$ using Cramer's rule. (CO1)
12. A) Show that $\cos 40^\circ + \cos 80^\circ + \cos 160^\circ = 0$. (CO2)
B) Prove that $\tan^{-1} \left(\frac{1}{4} \right) + \tan^{-1} \left(\frac{3}{5} \right) = \frac{\pi}{4}$ (CO2)
13. A) Solve $2\cos^2 \theta - 3\cos \theta + 1 = 0$. (CO2)
B) If $a = 5$, $b = 7$, $C = 30^\circ$, then find the area of the ΔABC . (CO2)
14. A) Find the line passing through the point $(2,3)$ and perpendicular to the line $x - 7y + 15 = 0$. Also find the distance from the given point to the given line. (CO3)
B) Find the vertex, focus, directrix and latus rectum of the parabola $y^2 = 16x$. (CO3)



15. A) Find the derivative of $3\cos x + \log x + 21x + 8e^{-x}$ w.r.t.x. (CO4)

B) Find the derivative of $\frac{1-x^2}{1+x^2}$ w.r.t. x. (CO4)

16. A) If $y = x^{\sin x}$, then find $\frac{dy}{dx}$. (CO4)

B) If $y = \tan^{-1} x$, then prove that $(1+x^2)\frac{d^2y}{dx^2} + 2x\frac{dy}{dx} = 0$. (CO4)

17. A) Find the equation of tangent to the curve $y = x^3 - 2x^2 + 4$ at (2,4). (CO5)

B) If $s(t) = t^2 + 2t + 3$ is the displacement of a particle, find its velocity and acceleration at the time $t=3$ sec. (CO5)

18. A) Find maximum or minimum value of $f(x) = 3 + 10x - 5x^2$. (CO5)

B) If an error of 0.02 cm is made in the side of a square, then what is the percentage error in the calculated value of its area? (CO5)

-o0o-



ENGINEERING PHYSICS

Course Code	Course title	No of periods/week	Total no of periods	Marks for FA	Marks for SA
EC-103	ENGINEERING PHYSICS	03	90	20	80

S.No	Major Topics	No. of Periods	COs
1.	Units and measurements	09	CO1
2.	Statics	11	
3.	Gravitation	12	
4.	Concepts of energy	10	CO2
5.	Thermal physics	10	CO3
6.	Sound	12	
7.	Electricity & magnetism	13	CO4
8.	Modern physics	13	
Total:		90	

Course objectives	<p>(1) To understand the basic concepts of physics for various Engineering applications as required for industries.</p> <p>(2) To equip the students with the scientific advances in technology and make the student suitable for any industrial organization.</p>
-------------------	--

COURSE OUTCOMES	CO1	Familiarize with various physical quantities, their SI units and errors in measurements; understand the concepts of vectors and various forces in statics.
	CO2	Understand the concepts of gravitation with reference to applications in satellites, provides the knowledge of various forms of energy and their working principles.
	CO3	Familiarize with the knowledge of conduction of heat and gas laws; provides the knowledge on musical sound and noise as pollution and also the concepts of echo and reverberation.
	CO4	Provide basic knowledge of electricity and concepts of magnetism and magnetic materials; familiarize with the advances in Physics such as photoelectric cell, optical fibers, semiconductors, superconductors and nanotechnology.

MATRIX SHOWING MAPPING OF COURSE OUTCOMES WITH PROGRAMME OUTCOMES

	PO1	PO2	PO3	PO4	PO5	PO6	PO7
CO1	3	1	2	1			2
CO2	3		2	2	1		2
CO3	2				1		
CO4	2	2	2	2	2		3

3 = strongly mapped, 2 = moderately mapped, 1 = slightly mapped

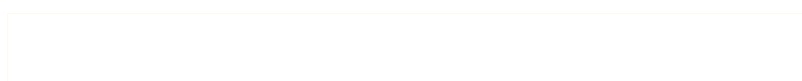

LEARNING OUTCOMES

1.0 Understand the concept of units and measurements

- 1.1 Explain the concept of Units
- 1.2 Define the terms
 - a) Physical quantity, b) Fundamental physical quantities and
 - c) Derived physical quantities
- 1.3 Define unit
- 1.4 Define fundamental units and derived units
- 1.5 State SI units with symbols
- 1.6 State Multiples and Submultiples in SI system
- 1.7 State rules of writing S.I. units
- 1.8 State advantages of SI units
- 1.9 What are direct and indirect measurements.
- 1.10 Define accuracy and least count
- 1.11 Define error in measurement
- 1.12 Define absolute, relative and percentage errors with their formulae
- 1.13 Solve simple problems on absolute, relative and percentage errors

2.0 Understand the concepts of statics

- 2.1 Explain the concept of Vectors
- 2.2 Define scalar and vector quantities with examples
- 2.3 Represent vectors geometrically
- 2.4 Define the types of vectors (equal, negative, unit, co-initial, co-planar vectors, Position vector)
- 2.6 Resolve the vector into rectangular components
- 2.7 State and explain triangle law of addition of vectors
- 2.8 Define concurrent and co-planar forces
- 2.9 State and explain Lami's theorem
- 2.10 State parallelogram law of addition of forces with diagram
- 2.11 Write the expressions for magnitude and direction of resultant (no derivation)
- 2.12 Illustrate parallelogram law with examples (i) flying of bird and (ii) working of sling.
- 2.13 Define moment of force and couple.
- 2.14 Write the formulae and S.I units of moment of force and couple.
- 2.15 Solve simple problems on (i) Resolution of force and (ii) Parallelogram law of forces (finding R, α and θ).

3.0 Understand the concepts of Gravitation

- 3.1 State and explain Newton's universal law of gravitation.
- 3.2 Define G and mention its value.
- 3.3 Explain the acceleration due to gravity (g)
- 3.4 Explain the factors affecting the value of g
- 3.5 Derive the relationship between g and G .
- 3.6 State and explain the Kepler's law of planetary motion
- 3.7 Define a satellite.
- 3.8 What are natural and artificial satellites? Give examples.
- 3.9 Define orbital velocity and write its formula.
- 3.10 Define escape velocity and write its formula.
- 3.11 Write a brief note on PSLV
- 3.12 Write a brief note on GSLV



- 3.13 Mention the applications of artificial satellites
- 3.14 Solve simple problems on (i) Newton's law of gravitation and (ii) calculation of orbital and escape velocities.

4.0 Understand the concepts of Energy.

- 4.1 Define work done and energy. Mention their SI units.
- 4.2 List various types of energy.
- 4.3 Define P.E with examples. Write its equation.
- 4.4 Define K.E with examples. Write its equation.
- 4.5 Derive relationship between K.E and momentum.
- 4.6 State the law of conservation of energy. Give various examples.
- 4.7 Write a brief note on solar energy.
- 4.8 Explain the principle of solar thermal conversion.
- 4.9 Explain the principle of photo voltaic effect
- 4.10 Solve simple problems on (i) work done (ii) P.E & K.E and (iii) Relation between K.E & momentum.

5.0 Understand the concepts of thermal physics

- 5.1 Define the concepts of heat and temperature
- 5.2 State the modes of transmission of heat
- 5.3 Define conduction, convection and radiation with two examples each.
- 5.4 State and explain Boyle's law
- 5.5 Define absolute zero temperature
- 5.6 Explain absolute scale of temperature
- 5.7 State the relationship between Degree Celcius, Kelvin and Fahrenheit temperatures
- 5.8 State Charles laws and write its equation
- 5.9 State Gay-Lussac's law and write its equation
- 5.10 Define ideal gas
- 5.11 Derive ideal gas equation
- 5.12 Explain why universal gas constant (R) is same for all gases
- 5.13 Calculate the value of R for 1 gram mole of gas.
- 5.14 Solve simple problems on (i) Interconversion of temperatures between °C, K and F (ii) Gas laws and (iii) Ideal gas equation.

6.0 Understand the concepts of Sound

- 6.1 Define the term sound
- 6.2 Define longitudinal and transverse waves with one example each
- 6.3 Explain the factors which affect the velocity of sound in air
- 6.4 Distinguish between musical sound and noise
- 6.5 Explain noise pollution and state SI unit for intensity of sound
- 6.6 Explain sources of noise pollution
- 6.7 Explain effects of noise pollution
- 6.8 Explain methods of minimizing noise pollution
- 6.9 Define Doppler effect
- 6.10 List the Applications of Doppler effect
- 6.11 Define reverberation and reverberation time
- 6.12 Write Sabine's formula and name the parameters contained
- 6.13 Define echoes and explain the condition to hear an echo.
- 6.14 Mention the methods of reducing an echo
- 6.15 Mention the applications of an echo



- 6.16 What are ultrasonics
- 6.17 Mention the applications of ultrasonics, SONAR,
- 6.18 Solve simple problems on echo

7.0 Understand the concepts of Electricity and Magnetism

- 7.1 Explain the concept of P.D and EMF
- 7.2 State Ohm's law and write the formula
- 7.3 Explain Ohm's law
- 7.4 Define resistance and specific resistance. Write their S.I units.
- 7.5 State and explain Kichoff's first law.
- 7.6 State and explain Kirchoff's second law.
- 7.7 Describe Wheatstone's bridge with legible sketch.
- 7.8 Derive an expression for balancing condition of Wheatstone's bridge
- 7.9 Describe Meter Bridge experiment with necessary circuit diagram.
- 7.10 Write the formulae to find resistance and specific resistance in meter bridge
- 7.11 Explain the concept of magnetism
- 7.12 What are natural and artificial magnets (mention some types)
- 7.13 Define magnetic field and magnetic lines of force and write the properties of magnetic lines of force
- 7.14 State and explain the Coulomb's inverse square law of magnetism
- 7.15 Define magnetic permeability
- 7.16 Define para, dia, ferro magnetic materials with examples
- 7.17 Solve simple problems on (i) Ohm's law (ii) Kirchoff's first law (iii) Wheatstone bridge (iv) meter bridge and (v) Coulomb's inverse square law

8.0 Understand the concepts of Modern physics

- 8.1 State and Explain Photo-electric effect
- 8.2 State laws of photoelectric effect
- 8.3 Explain the Working of photoelectric cell
- 8.4 List the Applications of photoelectric effect
- 8.5 Recapitulate refraction of light and its laws
- 8.6 Define critical angle
- 8.7 Explain the Total Internal Reflection
- 8.8 Explain the principle and working of Optical Fiber
- 8.9 List the applications of Optical Fiber
- 8.10 Explain the energy gap based on band structure
- 8.11 Distinguish between conductors, semiconductors and insulators base on energy gap
- 8.12 Define doping
- 8.13 Explain the concept of hole
- 8.14 Explain the types of semiconductors : Intrinsic and extrinsic
- 8.15 What are n-type and P-type semiconductors
- 8.16 Mention the applications of semiconductors
- 8.17 Define super conductor and superconductivity
- 8.18 List the applications of superconductors
- 8.19 Nanotechnology definition, nonmaterials and applications

COURSE CONTENT

1. Units and measurements

Introduction – Physical quantity – Fundamental and Derived quantities – Fundamental and

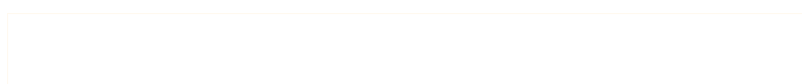

derived units - SI units –Multiples and Sub multiples – Rules for writing S.I. units- Advantages of SI units – Direct and indirect measurements – Accuracy and least count – Errors : Absolute, relative and percentage errors – Problems.

2. Statics

Scalars and Vectors – Representation of a vector - Types of vectors - Resolution of vector into rectangular components – Triangle law of vectors – Concurrent forces - Lami's theorem - Parallelogram law of forces : Statement, equations for magnitude and direction of resultant, examples – Moment of force and couple – Problems.

3. Gravitation

Newton's law of gravitation and G – Concept of acceleration due to gravity (g) – Factors affecting the value of g – Relation between g and G- Kepler's laws – Satellites : Natural and artificial – Orbital velocity and escape velocity – Polar and geostationary satellites – Applications of artificial satellites – Problems.

4. Concepts of energy

Workdone & Energy-Definition and types of energy - potential energy - kinetic energy-- K.E and Momentum relation – Law of Conservation of energy, examples - Solar energy, principle of thermal and photo conversion – Problems.

5. Thermal physics

Modes of transmission of heat - Expansion of Gases - Boyle's law - Absolute scale of temperature - Thermometric scales and their inter conversion - Charle's law - Gay-Lussac's law - Ideal gas equation - Universal gas constant (R) - Problems.

6. Sound

Sound - Nature of sound - Types of wave motion, Longitudinal and transverse – Factors affecting the velocity of sound in air - musical sound and noise - Noise pollution – Causes & effects- Methods of reducing noise pollution- Doppler effect- Echo- Reverberation- Reverberation time-Sabine 's formula - Ultrasonics & applications – SONAR - Problems.

7. Electricity & Magnetism

Concept of P.D and EMF - Ohm's law and explanation- Specific resistance- Kirchoff's laws - Wheatstone's bridge - Meter bridge.

Natural and artificial magnets – magnetic field and magnetic lines of force - Coulomb's inverse square law – Permeability – Magnetic materials – Para, dia, ferro – Examples – Problems.

8. Modern Physics

Photoelectric effect – laws of photoelectric effect – photoelectric cell - Applications of photo electric cell - Total internal reflection- Fiber optics - Principle and working of an optical fiber- Applications of optical fibers – Semiconductors : Based on Energy gap – Doping – Hole - Intrinsic and extrinsic semiconductors (n-type & p-type) – Applications of semiconductors - Superconductivity – applications – Nanotechnology definition, nano materials, applications.

REFERENCES

1. Intermediate physics - Volume - I & 2, Telugu Academy (English version)
2. Unified physics Volume 1, 2, 3 and 4, Dr. S.L Gupta and Sanjeev Gupta
3. Concepts of Physics, Vol 1 & 2, H.C. Verma

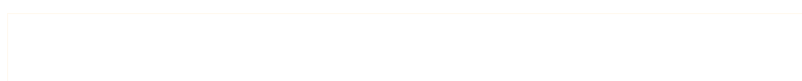

4. Text book of physics Volume I, Resnick & Holiday
5. Fundamentals of physics, Brijlal & Subramanyam
6. Text book of applied physics, Dhanpath Roy
7. NCERT Text Books of physics, Class XI & XII Standard
8. e-books/e-tools/websites/Learning Physics software

Blue Print for setting question paper at different levels

S.No	Major Topics	Weightage of Marks	Short Answer Type(Marks)			Essay Type(Marks)		
			R	U	A	R	U	A
1	Units and measurements	03	0	0	3	0	0	0
2	Statics	13	0		3	0	10	0
3	Gravitation	20	0	0	0	10	10	0
4	Concepts of energy	13	0	0	3	0	10	0
5	Thermal physics	13	0	3	0	0	0	10
6	Sound	16	0	3	3	0	10	0
7	Electricity & magnetism	16	0	3	3	0	10	0
8	Modern Physics	16	3	0	3	0	0	10
	Total:	110	3	9	18	10	50	20



(Model Paper)
State Board of Technical Education and Training, A. P
Diploma in Electronics and Communication Engineering (DECE)
First Year
Subject Name: ENGINEERING PHYSICS
Sub Code: EC - 103

C -23, EC -103

Time : 90 minutes

Unit Test-I

Max.Marks:40

Part-A

16Marks

Instructions: (1) Answer all questions.

(2) First question carries four marks, each question of remaining carries three marks

1. (i) Which among the following is a fundamental quantity.
(a) Force (b) Momentum (c) Time (d) Density (CO1)
- (ii) Pascal is the S.I unit of pressure. (True/ False) (CO1)
- (iii) Displacement is vector quantity (Yes/No) (CO1)
- (iv) The formula for orbital velocity is _____ (Fill in the blank) (CO2)
2. Define absolute, relative errors and percentage errors. (CO1)
3. Define equal vectors, unit vector and co-initial vectors. (CO1)
4. A force of 100 N acts at a point at an angle of 60° to the horizontal. Find the horizontal and vertical components of force. (CO1)
5. Define natural and artificial satellites. Give one example each. (CO2)

Part-B

3×8=24

Instructions: (1) Answer all questions.

(2) Each question carries eight marks

(3) Answer should be comprehensive and the criterion for valuation is the content but not the length of the answer.

6. (a) Define concurrent and co-planar forces. Explain Lami's theorem. (CO1)
- OR
- (b) Two forces 20 N and 30 N act at a point at an angle of 60° between them. Find the magnitude and direction of the resultant. (CO1)
7. (a) State and explain Kepler's law of planetary motion. (CO2)
- OR
- (b) Define acceleration due to gravity (g). Write any three factors affecting the value of g. (CO2)
8. (a) Write a brief note on PSLV and GSLV. (CO2)
- (OR)
- (b) State Newton's universal law of gravitation and derive the relationship between g and G. (CO2)

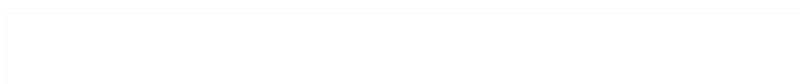

(Model Paper)

C-23, EC -103

State Board of Technical Education and Training, A. P
Diploma in Electronics and Communication Engineering (DECE)

First Year

Subject Name: ENGINEERING PHYSICS

Sub Code: EC - 103

Time : 90 minutes

Unit Test-II

Max.Marks:40

Part-A

16Marks

Instructions: (1) Answer all questions.

(2) First question carries four marks, each question of remaining carries three marks

- 1 (i) Which among the following is unit of Work.
(a) newton (b) pascal (c) joule (d) watt (CO2)
- (ii) According to Boyle's law, at constant temperature, the pressure of a gas is directly proportional to its volume (True/ False) (CO3)
- (iii) Velocity of sound in a medium varies with temperature (Yes/No) (CO3)
- (iv) The S.I unit of intensity of sound _____ (Fill in the blank) (CO3)
- 2 Define potential energy, give one example. (CO2)
- 3 Briefly write about absolute scale of temperature. (CO3)
- 4 An ideal gas of given mass at temperature 100 °C occupies a volume of 240 CC at constant pressure. Find its volume at 150 °C. (CO3)
5. Write any three differences between musical sound and noise. (CO3)

Part-B

3×8=24

Instructions: (1) Answer all questions.

(2) Each question carries eight marks

(3) Answer should be comprehensive and the criterion for valuation is the content but not the length of the answer.

6. (a) Write about solar energy and solar thermal conversion. (CO2)

OR

- (b). Define kinetic energy and derive the relationship between KE and momentum. (CO2)

7. (a) Write ideal gas equation and calculate the value of R for 1 gram mole of a gas. (CO3)

OR

- (b) Define conduction, convection and radiation with one example each. (CO3)

8. (a) Write four methods of reducing an echo and four applications of echo. (CO3)

(OR)

- (b) What are ultrasonics. Mention six applications of it. (CO3)



(Model Paper)
State Board of Technical Education and Training, A. P
Diploma in Electronics and Communication Engineering (DECE)
First Year
Subject Name: ENGINEERING PHYSICS
Sub Code: EC - 103

C –23, EC -103

Time : 90 minutes

Unit Test-III

Max.Marks:40

Part-A

16Marks

Instructions: (1) Answer all questions.

(2) First question carries four marks, each question of remaining carries three marks

1. (i) The unit of specific resistance is
(a) Ω (b) Ω /m (c) $\Omega -m$ (d) pascal (CO4)
- (ii) Magnetic field lines are open curves. (True/False) (CO4)
- (iii) At the critical angle, the angle of refraction is equal to 90° . (Yes/No) (CO4)
- (iv) Photoelectric cell converts ____ energy into electric energy (Fill in the blank) (CO4)
2. Find the current passing through a conductor of resistance 2Ω when P.D of 50 V is applied across it. (CO4)
3. State the Coulomb's inverse square law of magnetism and write the equation for it. (CO4)
4. State three laws of photo electric effect. (CO4)
5. Write any three applications of superconductors. (CO4)

Part-B

3×8=24

Instructions: (1) Answer all questions.

(2) Each question carries eight marks

(3) Answer should be comprehensive and the criterion for valuation is the content but not the length of the answer.

6. (a) State and explain Kirchoff's laws. (CO4)
OR
(b) Draw circuit diagram of Meter bridge. Two resistors of 10Ω and 30Ω are connected in the left and right gaps of a meter bridge. Find the balancing length. (CO4)
7. (a) Define para, ferro and dia magnetic materials with two examples each. (CO4)
OR
(b) Explain the principle and working of an optical fiber. (CO4)
8. (a) Explain intrinsic and extrinsic semiconductors. (CO4)
OR
(b) Explain conductors, semiconductors and insulators based on energy gap. (CO4)



MODEL PAPER
BOARD DIPLOMA EXAMINATIONS
C-23, EC-103, ENGINEERING PHYSICS
FIRST YEAR
YEAR END EXAMINATION

TIME:3 HOURS

MAX MARKS:80

Part-A

10×3=30

Instructions: (1) Answer all questions.

(2) Each question carries three marks

(3) Answer should be brief and straight to the point and shall not exceed five simple sentences.

1. Write any three advantages of S.I units. (CO1)
2. Define moment of force. Write its SI unit. (CO1)
3. Find the work done in lifting a body of mass 10 kg through a height of 20 m against gravity. (CO2)
4. Define absolute zero temperature. Convert -10°C into Kelvin temperature. (CO3)
5. Define Doppler effect. Mention one application. (CO3)
6. Write the Sabine's formula for reverberation time and name the parameters in it. (CO3)
7. Define specific resistance. Write its S.I unit. (CO4)
8. Write any three characteristics of magnetic lines of force. (CO4)
9. Draw a neat diagram of photoelectric cell and name the parts. (CO4)
10. Write any three applications of optical fibers (CO4)

Part-B

5×10=50

Instructions:(1) Answer any 5 questions.

(2) Each question carries 10 marks

(3) Answer should be comprehensive and the criterion for valuation is the content but not the length of the answer.

11. (a) State and explain triangle law of vectors. (CO2) (6 Marks)
(b) A force of 100 N acts on a particle at an angle of 30° to the horizontal.
Find the horizontal and vertical components of force. (CO2) (4 Marks)
12. State and explain Kepler's law of planetary motion. (CO1) (10 Marks)
13. (a) Derive the relationship between g and G . (CO2) (5 Marks)
(b) Calculate the orbital velocity of a satellite so that it revolves around the earth if the Radius of earth = 6.5×10^6 m, mass of earth = 6×10^{24} kg and Gravitational constant $G = 6.67 \times 10^{-11}$ Nm²/kg². (CO2) (5 Marks)
14. Explain the principle of solar thermal conversion and photo voltaic effect. (CO2) (5+5)
15. (a) Derive the ideal gas equation. (CO3) (7 Marks)
(b) Volume of a gas at 27°C is 100 CC. Keeping the pressure constant, find its volume at a temperature of 50°C . (CO3) (3 Marks)

16. (a) Write any five methods of reducing noise pollution. (CO3) (5 Marks)
(b) Define echo. Write three applications of it. (CO3) (2+3)
17. (a) Derive an expression for balancing condition of Wheatstone's bridge with neat circuit diagram.
(b) The values of resistance of P, Q, R are $50\ \Omega$, $10\ \Omega$ and $15\ \Omega$ respectively in the balanced condition of the bridge. Find the unknown resistance S. (CO4)(3 Marks)
18. Explain n-type and P-type semiconductors. (CO4) (5+5)

-000-

EC-104, ENGINEERING CHEMISTRY AND ENVIRONMENTAL STUDIES

Course code	Course Title	No. of Periods per week	Total No. of Periods	Marks for FA	Marks for SA
EC-104	ENGINEERING CHEMISTRY AND ENVIRONMENTAL STUDIES	3	90	20	80

S.No	Unit Title/Chapter	No of Periods	COs Mapped
1	Fundamentals of Chemistry	14	CO1
2	Solutions, Acids and Bases	16	CO1
3	Electrochemistry	12	CO2
4	Corrosion	8	CO2
5	Water Treatment	8	CO3
6	Polymers & Engineering materials	12	CO4
7	Fuels	6	CO4
8	Environmental Studies	14	CO5
	Total	90	

Course Objectives

Course Title: Engineering Chemistry & Environmental Studies	
Course Objectives	<ol style="list-style-type: none"> 1. To familiarize with the concepts of chemistry involved in the process of various Engineering Industrial Applications. 2. To know the various natural and man-made environmental issues and concerns with an interdisciplinary approach that include physical, chemical, biological and socio cultural aspects of environment. 3. to reinforce theoretical concepts by conducting relevant experiments/exercises

Course outcomes

Course Outcomes	CO1	Explain Bohr`s atomic model, chemical bonding, mole concept, acids and bases, P ^H and Buffer solutions
	CO2	Explain electrolysis, Galvanic cell, batteries and corrosion
	CO3	Explain the chemistry involved in the treatment of hardness in water
	CO4	Explain the methods of preparation of polymers and chemical composition and applications of alloys, composite materials, liquid crystals and Nano materials
	CO5	Explain Global impacts due to air pollution, causes , effects and control methods of water pollution and Understand the environment, forest resources, E-Pollution and Green Chemistry Principles.

EC-104	Engineering. Chemistry and Environmental studies No of Course Objectives:5			No Of periods 90	
POs	Mapped with CO No	CO periods addressing PO in Col 1		Level 1,2,3	remarks
		NO	%		
PO1	CO1,CO2,CO3, CO4,CO5	42	46.7 %	3	>40% level 3 (highly addressed) 25% to 40% level2(moderately addressed 5% to 25% level1 (Low addressed < 5%(not addressed)
PO2	CO1,CO2	9	10.0%	1	
PO3	CO2,CO3	8	8.9%	1	
PO4	CO1	10	11.1%	1	
PO5	CO4,CO5	13	14.4%	1	
PO6					
PO7	CO4	8	8.9%	1	

COs-POs mapping strength (as per given table)

	PO1	PO2	PO3	PO4	PO5	PO6	PO7	PSO1	PSO2	PSO3
CO1	3	1		1				1	1	
CO2	3	1	1					1	1	
CO3	3		1							
CO4	3				1		1			
CO5	3				1			1		
Average	3	1	1	1	1		1	1	1	

3=strongly mapped 2= moderately mapped 1= slightly mapped

Note: The gaps in CO and PO mapping will be achieved by one or more appropriate activities from the following:

- i) Seminars ii) Tutorials iii) Guest Lectures iv) Assignments v) Quiz competitions vi) Industrial visit vii) Tech Fest viii) Mini project ix) Group discussions x) Virtual classes xi) Library visit for e-books

Model Blue Print with Weightage for Blooms category and questions for each chapter and COs mapped

S.No	Unit Title/Chapter	No of Periods	Weight age of marks	Marks wise distribution of Weightage				Question wise distribution of Weightage				Mapped with CO
				R	U	A p	An	R	U	A p	An	
1	Fundamentals of Chemistry	14	21	15*	3	3		1½*	1	1		CO1
2	Solutions, Acids and Bases	16	21	8*	10	0	3	1½*	1		1	CO1
3	Electrochemistry	12	13	0	10	3			1	1		CO2
4	Corrosion	8	13	3	10	0		1	1			CO2
5	Water Treatment	8	13	10	0	0	3	1			1	CO3
6	Polymers & Engineering materials.	12	13	0	10	3		0	1	1		CO4
7	Fuels	6	3	0	0	3		0		1		CO4

8	Environmental Studies	14	13	0	13	0			2			CO5
Total		90	110	36	56	12	6	5	7	4	2	

***One question of 10 marks be given with 50% weightage from unit title 1 and 2**

LEARNING OUTCOMES

1.0 Atomic structure

- 1.1 Explain the charge, mass of fundamental particles of an atom (electron, proton and neutron) and the concept of atomic number and mass number.
- 1.2 State the Postulates of Bohr's atomic theory and its limitations.
- 1.3 Explain the significance of four Quantum numbers and draw the atomic structures of Silicon and Germanium.
- 1.4 Explain 1. Aufbau principle, 2 Pauli's exclusion principle 3 Hund's principle.
- 1.5 Define Orbital of an atom and draw the shapes of s, p and d- Orbitals.
- 1.6 Write the electronic configuration of elements up to atomic number 30
- 1.7 Explain the significance of chemical bonding
- 1.8 Explain the Postulates of Electronic theory of valency
- 1.9 Define and explain Ionic and Covalent bonds with examples of NaCl , *H₂, *O₂ and *N₂. (* Lewis dot method)
- 1.10 List out the Properties of Ionic compounds and covalent compounds and distinguish between their properties.

2.0 Solutions, Acids and Bases

- 2.1 Define the terms 1. Solution, 2. Solute and 3. Solvent
- 2.2 Classify solutions based on solubility.
- 2.3 Define mole and problems on mole concept.
- 2.4 Define the terms 1. Atomic weight, 2. Molecular weight and 3. Equivalent weight and calculate Molecular weight and Equivalent weight of the given acids. (HCl, H₂SO₄, H₃PO₄) Bases (NaOH, Ca(OH)₂, Al(OH)₃) and Salts (NaCl, Na₂CO₃, CaCO₃)
- 2.5 Define molarity and normality and numerical problems on molarity and normality (a) Calculate the Molarity or Normality if weight of solute and volume of solution are given (b) Calculate the weight of solute if Molarity or normality with volume of solution are given (c) Problems on dilution to convert high concentrated solutions to low concentrated Solutions
- 2.6 Explain Arrhenius theory of Acids and Bases and give the limitations of Arrhenius theory of Acids and Bases.
- 2.7 Define ionic product of water and pH and numerical problems on pH (Strong Acids and Bases).
- 2.8 Define buffer solution and classify buffer solutions with examples. Give its applications.

3.0 Electrochemistry

- 3.1 Define the terms 1. Conductor 2. Semiconductor 3. Insulator, 4. Electrolyte 5. Non-electrolyte. Give two examples each.
- 3.2 Distinguish between metallic conduction and Electrolytic conduction
- 3.3 Explain electrolysis by taking example fused NaCl and list out the applications of electrolysis.

- 3.4 Define Galvanic cell and explain the construction and working of Galvanic cell.
- 3.5 Distinguish between electrolytic cell and galvanic cell.
- 3.6 Define battery and list the types of batteries with examples.
- 3.5 Explain the construction, working and applications of i) Dry cell (Leclanche cell, ii) Lead storage battery iii) Lithium-Ion battery iii) Hydrogen-Oxygen fuel cell.

4.0 Corrosion

- 4.1 Define the term corrosion.
- 4.2 state the Factors influencing the rate of corrosion
- 4.3 Describe the formation of a) composition cell b) stress cell c) concentration cell during corrosion.
- 4.4 Define rusting of iron and explain the mechanism of rusting of iron.
- 4.5 Explain the methods of prevention of corrosion
 - a) Protective coatings (anodic and cathodic coatings)
 - b) Cathodic protection (Sacrificial anode process and Impressed-voltage process)

5.0 Water Treatment

- 5.1 Define soft water and hard water with respect to soap action.
- 5.2 Define and classify the hardness of water.
- 5.3 List out the salts that causing hardness of water(with Formulae)
- 5.4 State the disadvantages of using hard water in industries.
- 5.5 Define Degree of hardness and units of hardness(mg/L) or(ppm).
- 5.6 Numerical problems on hardness.
- 5.7 Explain the methods of softening of hard water by :a) Ion-exchange process, b) Reverse Osmosis.

6.0 Polymers & Engineering materials.

- A) Polymers
- 6.1 Explain the concept of polymerisation
- 6.2 Describe the methods of polymerization a)addition polymerization of ethylene b)condensation polymerization of Bakelite (Only flow chart)
- 6.3 Explain the methods of preparation and uses of the following plastics:
 - 1. PVC 2.Teflon 3. Polystyrene 4. Nylon 6,6
- B) Engineering materials
- 6.4 Define an alloy. Write the composition and applications of the following.
 - 1.Nichrome 2. Duraluminium 3. Stainless Steel.
- 6.5. Define elastomers: Write the composition and applications of the following
 - 1. Buna- S 2. Neoprene
- 6.6 Define Composite materials: Write the composition and applications of the following:
 - 1.Glass Fibre Reinforcement composites(GFR) 2. Carbon Fibre Reinforcement Composites(CFR)
- 6.7 Define Liquid Crystals. Classify and give applications of the following:
 - 1. Nematic 2. Smectic crystals

6.7 Define Nano materials. Write the composition and applications of the following:

1. nanotubes
2. Nano crystals.

7.0 Fuels

7.1 Define the term fuel

7.2 Classify the fuels based on occurrence.

7.3 Write the composition and uses of the following:

1. LPG
2. CNG
3. Biogas
4. Power alcohol

7.4 Write the commercial production of Hydrogen as future fuel. Give its advantages and disadvantages.

8.0 ENVIRONMENTAL STUDIES

8.1 Define the term environment and explain the scope and importance of environmental studies.

8.2 Define the segments of environment 1).Lithosphere 2).Hydrosphere 3).Atmosphere 4)Biosphere

8.3 Define the following terms:

- 1)Pollutant
- 2).Pollution
- 3).Contaminant
- 4)receptor
- 5)sink
- 6) particulates
- 7)dissolved oxygen (DO)
- 8)Threshold limit value (TLV)
- 9).BOD
- 10) COD
- 11) eco system
- 12) Producers
- 13) Consumers
- 14) Decomposers with examples.

8.4 State the renewable and non- renewable energy sources with examples.

8.5 State the uses of forest resources.

8.6 Explain the causes and effects of deforestation

8.7 Define air pollution and give its Global impacts (1) Greenhouse effect, 2) Ozone layer depletion and 3) Acid rain

8.8 Define Water pollution. Explain the causes, effects and control methods of Water pollution.

8.9 Define E-Pollution, State the sources of e-waste Explain its health effects and control methods.

8.10 Define green chemistry. Write the Principles and benefits of green chemistry.

COURSE CONTENT

1. Fundamentals of Chemistry

Atomic Structure: Introduction - Fundamental particles – Bohr's theory – Quantum numbers –Aufbau principle - Hund's rule - Pauli's exclusion Principle- Orbitals, shapes of s, p and d orbitals - Electronic configurations of elements

Chemical Bonding: significance–Electronic theory of valency- types of chemical bonds – Ionic and covalent bond with examples–Properties of Ionic and Covalent compounds.

2. Solutions, Acids and Bases

Solutions: Terms and Types of solutions- mole concept –numerical problems on mole concept –Methods of expressing concentration of a solution –molarity and normality – Numerical problems on molarity and normality.

Acids and Bases: Arrhenius theory of acids and bases – Ionic product of water- pH – numerical problems on pH–Buffer solutions- Classification- applications.

3. Electrochemistry

Conductors, semiconductors, insulators, electrolytes and non-electrolytes – electrolysis of fused NaCl--applications of electrolysis - Galvanic cell – Battery-Types- Dry Cell(Leclanche

Cell), Lead Storage battery- Hydrogen –Oxygen fuel cell.

4. Corrosion

Introduction - factors influencing corrosion - composition, stress and concentration cells – rusting of iron and its mechanism – prevention of corrosion by coating methods, cathodic protection methods.

5. Water technology

Introduction – soft and hard water – causes of hardness – types of hardness – disadvantages of hard water – degree of hardness (ppm and mg/lit) – Numerical problems on hardness - softening methods – Ion- Exchange process – Reverse Osmosis.

6. Polymers & Engineering materials

Polymers: concept of polymerization – types of polymerization – addition, condensation with examples – Preparation and uses of the following plastics i) PVC ii) Teflon iii) Polystyrene iv) Nylon 6,6

Elastomers: Preparation and application of the following elastomers i) Buna-s ii) Neoprene
Engineering materials:

Alloys- composition and applications of i) Nichrome, ii) Duraluminium iii) Stainless Steel.

Composite materials- Composition and applications of i) GFR ii) CFR

Liquid Crystals- types- applications of i) Nematic Crystals ii) Smectic crystals

Nano materials- Composition and applications of i) Nanotubes ii) Nano crystals..

7. Fuels

Definition and classification of fuels – composition and uses of i) LPG ii) CNG iii) Biogas iv) Power alcohol

8. ENVIRONMENTAL STUDIES

Environment – scope and importance of environmental studies – important terms related to environment – renewable and non-renewable energy sources – Forest resources – Deforestation – Air pollution – Global impacts on environment – Water pollution – causes – effects – control measures – E-Pollution – Sources – health effects – control methods. Green Chemistry – Principles – Benefits

REFERENCE BOOKS

1. Telugu Academy, Intermediate chemistry Vol. 1&2
2. Jain & Jain, Engineering Chemistry
3. O.P. Agarwal, Hi- Tech. Engineering Chemistry
4. Sharma, Engineering Chemistry
5. A.K. De, Engineering Chemistry

Table specifying the scope of syllabus to be covered for Unit Test- 1, Unit Test- 2 and Unit Test -3

Unit Test	Learning outcomes to be covered
Unit Test - 1	From 1.1 to 2.8
Unit Test - 2	From 3.1 to 5.7
Unit Test - 3	From 6.1 to 8.10

UNIT TEST –I

Model Question Paper (C-23)

ENGINEERING CHEMISTRY & ENVIRONMENTAL STUDIES (104)

TIME: 90 minutes

Total Marks: 40

PART-A

16 Marks

Instructions: (1) Answer all questions

(2) First question carries 4 marks and each of rest carries 3 marks.

(3) Answers for Q.No. 2 to 5 should be brief and straight to the point and shall not exceed five simple sentences.

1. a. Number electrons present in Na^+ ion is ----- (CO1)
b. The molarity and normality of NaOH is the same (True or False) (CO1)
c. Acid with pH 6 is stronger than Acid pH 4 (True or False) (CO1)
d. 2s is spherical shaped orbital but 3p is ----- (CO1)
2. Distinguish between orbit and orbital. (CO1)
3. Define buffer solution. Give two examples. (CO1)
4. Calculate the number of moles present 10.6 gm. of Na_2CO_3 .
5. Draw the atomic structures of Si and Ge. (CO1)

PART – B

3x8M = 24M

Answer either (A) or (B) from each questions from Part-B.

Each question carries 8 marks.

6. a) Explain Postulations of Bhor's atomic theory. Give its limitations. (CO1)
(OR)
b) Explain the significance of Quantum numbers. (CO1)
7. a) Define molarity normality. Calculate the molarity and normality of 10.6 gm of Na_2CO_3 present in 500 ml solution. (CO1)
(OR)
b) Explain Arrhenius theory of acids and bases. Give its limitations (CO1)
8. a) Define ionic bond. Explain the formation of ionic bond in NaCl . (CO1)
(OR)
b) Define solution. Explain the types of solutions based on its solubility. (CO1)

UNIT TEST –II
Model Question Paper (C-23)

ENGINEERING CHEMISTRY & ENVIRONMENTAL STUDIES (104)

TIME: 90 minutes

Total Marks:40

PART-A

16 Marks

Instructions: (1) Answer all questions.

(2) First question carries 4 marks and each of rest carries 3 marks.

(3) Answers for Q. No. 2 to 5 should be brief and straight to the point and shall not exceed five simple sentences.

1. a) Graphite is an insulator. (True of False) (CO2)
- b) ----- is an electrolyte in Hydrogen-Oxygen fuel cell (CO2)
- c) Zinc is more active than Iron. (True or False) (CO2)
- d) Write the Chemical formula of rust. (CO2)
2. Write any three differences between metallic conduction and electrolytic conduction.(CO2)
3. Write a short note on stress cell. (CO2)
4. Define hard water. Mention any two salts that cause hardness (CO3)
5. What is the role of salt bridge? (CO2)

PART – B

3x8M = 24M

Answer either (A) or (B) from each questions from Part-B.

Each question carries 8 marks.

6. a) Explain construction and working of galvanic cell with neat diagram . (CO2)
- (OR)
- b) Explain construction and working of Lead storage battery. (CO2)
7. a) Calculate the temporary, permanent and total hardness of water containing the following salts:
 CaSO₄ =13.6 mg/lit, Mg(HCO₃)₂ = 7.3 mg/lit ,
 Ca(HCO₃)₂ = 16.2 mg/lit, MgCl₂ = 9.5 mg/lit (CO3)
- (OR)
- b) Explain Ion-Exchange process of softening of hard water. (CO3)
8. a) What is rusting of iron? Explain Mechanism of rusting of iron. (CO2)
- (OR)
- b) Explain cathodic protection methods. (CO2)

UNIT TEST –III

Model Question Paper (C-20)

ENGINEERING CHEMISTRY & ENVIRONMENTAL STUDIES (104)

TIME: 90 minutes

Total Marks:40

PART-A

16 Marks

Instructions: (1) Answer all questions.

(2) First question carries 4 marks and each of rest carries 3 marks.

(3) Answers for Q. No. 2 to 5 should be brief and straight to the point and shall not exceed five simple sentences.

1. a) Semiconductor Nano Crystals are called (CO4)
b) Chloroprene is the monomer of Neoprene. (True/False) (CO4)
c) Give any two examples for green house gases. (CO5)
d) Presence of ozone in stratosphere is a pollutant. (Yes/No) (CO5)
2. Define liquid crystals. State the types. (CO4)
3. Write the commercial production of Hydrogen by electrolysis of water. (CO4)
4. Define Green Chemistry. List any two benefits. (CO5)
5. Define TLV. Give one example. (CO5)

PART – B

3x8M = 24M

Answer either (A) or (B) from each questions from Part-B.

Each question carries 8 marks.

6. a) Define polymerisation. Explain condensation polymerisation by taking nylon 6,6 as an example. (CO4)
(OR)
b) Define elastomers. Give a method of preparation and applications of Buna-S.(CO4)
7. a) What is air pollution? Discuss any one of Global impacts of air pollution. (CO5)
(OR)
b) Write the composition and uses of the following:
i) LPG ii) CNG iii) Biogas iv) Power Alcohol (CO4)
8. a) Define e-waste. State the sources and explain e-waste management. (CO5)
(OR)
b) Define water pollution. Write the causes of water pollution. (CO5)

Model Question Paper (C-23)

ENGINEERING CHEMISTRY & ENVIRONMENTAL STUDIES (104)

TIME: 3hrs

Total Marks:80

PART-A

Instructions: (1) Answer all questions. (2) Each question carries Three marks. 3x10=30M

1. Draw the atomic structures of Si and Ge. (CO1)
2. Write the anomalous electronic configuration of Chromium and Copper. (CO1)
3. State the limitations of Arrhenius theory of acids and bases. (CO1)
4. Define solution. Classify solutions based on solubility. (CO1)
5. State the applications of Li-ion batteries. (CO2)
6. List the factors that influence the rate of corrosion of metals. (CO2)
7. Mention disadvantages of hard water used in industries. (CO3)
8. State any three applications of nanotubes. (CO4)
9. Write the composition and uses of LPG. (CO4)
10. What is e-waste? State the sources of e-waste. (CO5)

PART – B

Instructions: (1) Answer any five questions. (2) Each question carries Ten marks.

10x5=50M

11. Explain the significance of quantum numbers. (CO1)
12. Define molarity and normality. Calculate the molarity and normality of 250 ml of solution that contains 5.3 gm of sodium carbonate. (CO1)
13. a) Define ionic bond. Explain the formation of ionic bond in NaCl. (CO1)
b) Define Buffer solution. Give any two examples and applications. (CO1)
14. a) Explain the construction and working of Fuel cells. (CO2)
b) State any four differences between electrolytic cells and Galvanic cells. (CO2)
15. a) Explain mechanism of rusting of iron. (CO2)
b) Write a short note on Sacrificial anodic method of prevention of corrosion. (CO2)
16. Define hard water. Explain ion-exchange of softening of hard water with a neat diagram. (CO3)
17. a) Define elastomer. Write a method of preparation and any two applications of Buna-s. (CO4)
b) What are Liquid Crystals? Give any two examples and applications. (CO4)
18. a) Define deforestation. State the impacts of deforestation. (CO5)
b) Write a short note on Ozone layer depletion. (CO5)

ELECTRONIC COMPONENTS & DEVICES

Course Code	Course title	No of periods/week	Total no of periods	Marks for FA	Marks for SA
EC-105	ELECTRONIC COMPONENTS & DEVICES	05	150	20	80

S No	Unit Title	No. of Periods	COs Mapped
1	Passive Components	20	CO1
2	Switches, Connectors, Relays and PCBs	20	
3	Semiconductor Physics	15	CO2
4	Semiconductor Diodes	15	
5	Bipolar Junction Transistor	20	CO3
6	Field Effect Transistor	20	
7	Opto Electronic Devices	20	CO4
8	Audio Systems	20	CO5
Total		150	

Course Objectives	1. To learn the principles of passive components, switches, relays and PCBs
	2. To Understand the formation of semiconductor materials and the working of semiconductor diode and to analyse the working of BJT and FET
	3. To analyse the working of Special semiconductor devices and to understand the working of Audio systems

CO No		COURSE OUTCOMES
CO1	EC-105.1	Familiarize different passive components, switches, relays. Describe PCB manufacturing Techniques and soldering methods
CO2	EC-105.2	Describe the formation and working of semiconductor diodes
CO3	EC-105.3	Analyse the working of BJT & FET configurations
CO4	EC-105.4	Analyse the working of Special Semiconductor Devices.
CO5	EC-105.5	Explain working principle of microphones and loudspeakers.

CO-PO/PSO MATRIX

CO No	PO1	PO2	PO3	PO4	PO5	PO6	PO7	PSO1	PSO2	PSO3
EC-105.1	3	3	2	2			1	3	1	1
EC-105.2	3	2	3		2		2	3	1	1
EC-105.3	3	3	2				2	3	1	1
EC-105.4	3	3	2	2	2		2	3	1	
EC-105.5	3	3	3	2	2	1	2	3	1	2
Average	3	2.8	2.2	2	2	1	1.4	3	1	1.25

3=strongly mapped 2=moderately mapped 1=slightly mapped

LEARNING OUTCOMES

1.0 Passive Components

- 1.1
 - i) Define the term resistance
 - ii) Define the term resistor & classify resistors
 - iii) Draw the circuit symbols of fixed and variable resistors
 - iv) List the specifications of a resistor
- 1.2 State the physical factors that affect the value of a resistor and calculate resistance value by using colour Code.
- 1.3 Compare the features of carbon and wire wound potentiometers
- 1.4 Explain the working of rheostat and mention its applications.
- 1.5 Define temperature co-efficient of resistance and explain the effects of temperature on resistance
- 1.6 Explain the working of thermistor and sensistor and mention their applications.
- 1.7
 - i) Define the term inductance
 - ii) Define the term inductor & classify inductors
 - iii) Draw the circuit symbols of different types of inductors
 - iv) List the specifications of an inductor
 - v) Define the term Stray inductance
- 1.8 List various core materials used in the construction of inductors
- 1.9 Explain the use of Ferrites in the construction of high frequency inductors
- 1.10 List the applications of A.F. and R.F chokes.
- 1.11
 - i) Define the term capacitance.
 - ii) Define the term capacitor & classify capacitors.
 - iii) Draw the circuit symbols of fixed and variable capacitors.
 - iv) List the specifications of a capacitor
 - v) Define the term Stray capacitance
- 1.12 State the factors affecting the capacitance of a capacitor.
- 1.13 Define Di-electric constant and Di-electric strength of a material.
- 1.14 State different types of variable capacitors and mention their applications.

2.0 Switches, Connectors, Relays and PCBs

- 2.1 Classify switches according to poles and throws (SPST, SPDT, DPST, DPDT, Multi-pole multi-throw)
- 2.2 Sketch the I.S.I symbols of various switches.
- 2.3 State the need of fuse in electronic equipment.
- 2.4 Mention different types of fuses.
- 2.5 State the necessity of connectors in electronic circuits.
- 2.6 List different types of connectors.
- 2.7 State the use of MCB.
- 2.8 Define a relay.
- 2.9 Classify different relays based on principle of operation, polarization and application.
- 2.10 List the specifications and applications of relays.
- 2.11 Explain the working of general purpose electromagnetic relay.
- 2.12 Explain the need of PCB in electronic equipment.
- 2.13 Classify PCBs and list the types of laminates used in PCBs.
- 2.14 List the methods of transferring layout on to the copper clad sheet.
- 2.15 List the materials used in screen-printing.
- 2.16 List the steps involved in screen-printing for making PCBs.
- 2.17 Explain the methods of etching, cleaning and drilling of PCB.
- 2.18 Explain the steps involved in making double-sided PCB.

- 2.19 Explain Surface Mount Technology and its uses.
- 2.20 List the materials used in soldering.
- 2.21 List the soldering methods of PCBs.

3.0 Semiconductor Physics

- 3.1 Define the terms conductivity and resistivity and give their equations
- 3.2 Define Valance band, Conduction band and Forbidden energy gap
- 3.3 Explain Energy Band diagrams of conductors, semiconductors and Insulators
- 3.4 Define Intrinsic Semiconductors and Fermi level
- 3.5 Define electron current and hole current
- 3.6 Explain the bipolar nature of semiconductors
- 3.7 State the need for doping.
- 3.8 Distinguish between intrinsic and extrinsic semiconductor
- 3.9 Explain the formation of P type and N type semiconductor
- 3.10 Compare P-type and N-type semiconductors
- 3.11 Explain Drift and Diffusion currents

4.0 Semiconductor Diodes

- 4.1 Explain the formation of PN junction diode.
- 4.2 Explain the working of PN junction Diode with forward & reverse biasing.
- 4.3 Draw the VI characteristics of a diode
- 4.4 State diode current equation
- 4.5 List the important specifications of a diode
- 4.6 Mention the applications of diode
- 4.7 Explain reverse breakdown phenomenon
- 4.8 Distinguish between Avalanche & Zener breakdowns
- 4.9 Explain the construction and working of Zener diode.
- 4.10 Draw the forward & reverse bias characteristics of Zener diode
- 4.11 Mention the applications of Zener diode
- 4.12 Explain the working principle of Varactor diode
- 4.13 List the applications of varactor diode.

5.0 Bipolar Junction Transistor

- 5.1 Explain the formation of bipolar junction transistor
- 5.2 Explain the working of PNP and NPN Transistors.
- 5.3 Draw the circuit symbols of NPN and PNP transistor
- 5.4 Draw the different transistor configurations
- 5.5 Sketch the input/output characteristics of CB, CE and CC configurations.
- 5.6 Identify the cut-off, saturation and active regions in output characteristics of CB , CE and CC Configurations
- 5.7 Define alpha, beta and gamma factors
- 5.8 Derive the relations among alpha, beta and gamma factors.
- 5.9 Write collector current expression in CB and CE modes of transistors in terms of α , β , I_E , I_B , I_C and I_{CBO} , I_{CEO} .
- 5.10 Compare the performance characteristics of CB, CE and CC configurations

6.0 Field Effect Transistor

- 6.1 Classify Field Effect Transistors

- 6.2 Explain the construction and working principle of N-channel JFET
- 6.3 Draw and explain the drain characteristics of JFET
- 6.4 Draw and explain the mutual characteristics of JFET
- 6.5 Define the parameters of JFET and obtain the relation among them.
- 6.6 List the advantages of FET over BJT
- 6.7 Explain the construction & working of N-channel Enhancement type MOSFET
- 6.8 Explain the construction & working of N-channel Depletion type MOSFET
- 6.9 Draw the Drain Characteristics of N-channel Depletion MOSFET
- 6.10 Compare JFET and MOSFET

7.0 Opto Electronic Devices

- 7.1 Explain the construction, operation and characteristics of photo diode.
- 7.2 Explain the construction, operation and characteristics of photo transistor.
- 7.3 List the applications of photo diode and photo transistor.
- 7.4 Explain the principle of LDR and list the applications of LDR
- 7.5 Explain the construction, working principle and characteristics of LED
- 7.6 List the applications of LED
- 7.7 Explain the working of opto-coupler
- 7.8 List the applications of opto-couplers
- 7.9 Explain the working principle of LCD
- 7.10 List the applications of LCD

8.0 Audio Systems

- 8.1 Explain the working of carbon, condenser, Crystal and dynamic microphones along with their polar characteristics.
- 8.2 Explain the constructional features and principle of operation of PMMC Loudspeaker and its ratings.
- 8.3 Mention the use of woofers and tweeters.
- 8.4 State the need for Horn loud speaker
- 8.5 Explain the construction & working of Horn loud speaker with suitable diagram
- 8.6 Explain the principle, construction and working of magnetic and crystal headphones and their uses.
- 8.7 List the specifications of Loudspeaker and Microphones
- 8.8 Define the terms: speech, music and noise.
- 8.9 Define the terms: Hi-Fi and Stereo related to audio system
- 8.10 State the features of home theatre sound system

COURSE CONTENTS

1. Passive components

Resistors: Resistance, resistor-Classification- Circuit symbols–Specifications-Physical factors- - Colour code-Carbon and wire wound potentiometers – Rheostat – Applications – Temperature coefficient of resistance - Effect of temperature on resistance – Thermistors, sensistors– Applications

Inductors: Inductance, Inductor-Classification - Circuit symbols – Specifications- Stray inductance - Core materials – Ferrites - AF and RF Chokes

- Capacitors:** Capacitance, Capacitor-Classification - Circuit symbols – Specifications – Stray Capacitance – Factors affecting capacitance- Dielectric constant - Dielectric strength – Variable capacitors - Applications
2. **Switches, Connectors, Relays and PCBs:** Switch- Classification – ISI symbols – Fuse – Types – Necessity of connectors – Types – MCB – Relay – Classification – Specifications – Applications – General purpose electromagnetic relay
PCBs: PCB – Classification – Methods of layout preparation - Methods of transferring layout – Screen printing materials- Steps – Etching, cleaning and drilling - Double sided PCB – Steps-Materials used in soldering – Soldering methods
 3. **Semiconductor Physics:** Energy level, Energy Band Diagrams compare conductors , semiconductors and insulators - Valance band, Conduction band and Forbidden energy gap – Semiconductor Materials – Hole conduction, Bi polar nature of semiconductor materials – Intrinsic Semiconductors - Extrinsic Semiconductors - P type & N type semiconductors- Drift and diffusion currents-
 4. **Semiconductor Diodes:** PN junction diode – Working - VI characteristics – Energy band diagrams- Potential barrier - Diode equation – Manufacturer specifications – Applications - Breakdown phenomenon – Avalanche and Zener breakdowns - Zener diode construction, working – Reverse bias characteristics –Applications- working principle of varactor diode- applications
 5. **BJT:** Transistor formation – PNP & NPN transistors- symbols - Construction – Working - CB, CE and CC configurations - I/p & O/p characteristics - Active, Cut-off and saturation regions – Alpha(α), Beta(β), Gamma (γ) factors- Relation- Collector current expression in CB and CE- Comparison of CB,CE,CC
 6. **Field Effect Transistor:** Classification –N channel JFET Construction, Principle of operation – Drain characteristics – Mutual characteristics – Parameters of JFET – Relationship - Advantages of JFET over BJT –N Channel enhancement MOSFET – Construction, working - N Channel depletion MOSFET – Construction, working - Drain and transfer characteristics of N channel Depletion MOSFET – Comparison of JFET and MOSFET
 7. **Opto-Electronic Devices**
Construction, working principle of photo diode, photo transistor, LED and their applications- opto-coupler-working principle of LCD-Applications.
 8. **Audio systems.**
carbon, condenser, Crystal and dynamic microphones- PMMC Loudspeaker- woofers and tweeters- Horn loud speaker-magnetic and crystal headphones –Specifications of loud speakers, microphones- speech, music and noise- - Hi-Fi and Stereo- - home theatre sound system.

REFERENCE BOOKS

1. G.K.Mithal, Electronic Devices and Circuits, 23rd Edition- Khanna Publication-1988
2. B. Somanathan, Electronic devices and applications, 2nd Edition- PHI.
3. Dr.K.Padmanabham, P.Swaminathan, Electronic components, 2nd Edition,-Laxmi Publications (P) Ltd
4. Walter c bosshard, Printed circuit boards: design and technology -TMH
5. Bernard Grob, Basic Electronics, 4th edition- TMH-1977
6. Millman&Halkias, Electronic devices & Circuits, 4th edition- TMH

BLUE PRINT

SI No	Unit Title	No of Periods	Weightage Allotted	Weightage of Marks		COs mapped
				No of Essay Questions	No of Short answer Questions	
1	Passive Components	20	16	1	2	CO1
2	Switches, Connectors, Relays and PCBs	20	13	1	1	
3	Semiconductor Physics	15	13	1	1	CO2
4	Semiconductor Diodes	15	13	1	1	
5	Bipolar Junction Transistor	20	13	1	1	CO3
6	Field Effect Transistor	20	13	1	1	
7	Opto-Electronic Devices	20	16	1	2	CO4
8	Audio Systems	20	13	1	1	CO5
		150	110	80	30	

Table specifying the scope of syllabus to be covered for Unit Tests

Unit Test	Learning outcomes to be covered
Unit Test-I	From 1.1 to 3.7
Unit Test-II	From 3.8 to 6.6
Unit Test-III	From 6.7 to 8.10

(Model Paper)
State Board of Technical Education and Training, A. P
Diploma in Electronics and Communication Engineering (DECE)
First Year

C –23, EC -105

Subject Name: Electronic Components and Devices

Sub Code: EC - 105

Time : 90 minutes

Unit Test-I

Max.Marks:40

Part-A

16Marks

Instructions: (1) Answer all questions.

(2) First question carries four marks, each question of remaining carries three marks

1. Draw the circuit symbols of following
 - a) Variable Resistor (CO1)
 - b) Single pole double throw (SPDT) switch (CO1)
 - c) Iron core inductor (CO1)
 - d) Double pole single throw (DPST) switch (CO1)
2. Classify the different types of inductors (CO1)
3. Define the term capacitance (CO1)
4. List the materials used in soldering. (CO1)
5. Define the terms resistivity and conductivity and give their equations. (CO2)

Part-B

3×8=24

Instructions: (1) Answer all questions.

(2) Each question carries eight marks

(3) Answer should be comprehensive and the criterion for valuation is the content but not the length of the answer.

6. (a) Explain the use of Ferrites in the construction of high frequency inductors (CO1)
(or)
(b) Explain the working of thermistor and sensistor. (CO1)
7. (a) Explain the working of general-purpose electromagnetic relay and mention its applications. (CO2)
(or)
(b) Explain the methods of etching, cleaning and drilling of PCB (CO1)
8. (a) Describe the steps involved in making double-sided PCB. (CO2)
(or)
(b) Compare conductors, semiconductors and insulators (CO2)

(Model Paper)

C –23, EC -105

State Board of Technical Education and Training, A. P
Diploma in Electronics and Communication Engineering (DECE)
First Year

Subject name: Electronic Components and Devices

Sub Code: EC - 105

Time : 90 minutes

Unit Test II

Max.Marks:40

Part-A

16Marks

Instructions: (1) Answer **all** questions.
(2) First question carries **four** marks, each question of remaining carries **three** marks

1. Draw the circuit symbols of following
 - a) NPN Transistor (CO3)
 - b) PNP Transistor (CO3)
 - c) Varactor diode (CO2)
 - d) Zener Diode (CO2)
2. Draw the VI characteristics of diode (CO2)
3. Write the collector current expression in CB Configuration (CO3)
4. Define alpha, beta and gamma factors of a transistor. (CO3)
5. List the advantages of JFET over BJTs (CO3)

Part-B

3×8=24M

Instructions: (1) Answer **all** questions.
(2) Each question carries **eight** marks
(3) Answer should be comprehensive and the criterion for valuation is the content but not the length of the answer.

6. (a) Describe the working of PN junction Diode with forward & reverse biasing. (CO2)
(or)
(b) Describe the formation of P- type and N- type semiconductor with energy band diagram (CO2)
7. (a) Explain the operation of NPN transistor (CO3)
(or)
(b) Draw and explain the out put characteristics of transistor CE configuration (CO3)
8. (a) Describe the construction and principle of n channel JFET (CO3)
(or)
(b) Draw and explain the mutual characteristics of JFET (CO3)

(Model Paper) **C –23, EC -105**
State Board of Technical Education and Training, A. P
Diploma in Electronics and Communication Engineering (DECE)
First Year

Subject Name: Electronic Components and Devices

Sub Code: EC - 105

Time : 90 minutes

Unit Test III

Max.Marks:40

Part-A

16Marks

Instructions: (1) Answer all questions.

(2) First question carries four marks, each question of remaining carries three marks

1. Draw the circuit symbols of following
 - a)N channel MOSFET (CO3)
 - b) LED I (CO4)
 - c) Photo Transistor (CO4)
 - d)L oud speaker (CO5)
2. Compare JFET and MOSFET (CO3)
3. List the applications of photo diode (CO4)
4. Define the terms speech, music and noise (CO5)
5. List the specifications of Microphones (CO5)

Part-B

3×8=24

Instructions: (1) Answer **all** questions.

(2) Each question carries **eight** marks

(3) Answer should be comprehensive and the criterion for valuation is the content but not the length of the answer.

6. (a) Explain the construction & working of N channel Enhancement type MOSFET (CO3)
OR
(b) Explain the construction, operation and characteristics of photo transistor. (CO3)
7. (a) Explain the construction, working principle and of LDR (CO4)
OR
(b) Explain the working of Opto-Coupler. (CO4)
8. (a) Explain the working of Carbon Microphone with their polar characteristics . (CO5)
OR
(b) Explain the construction and working horn loudspeaker with suitable diagram. (CO5)

MODEL PAPER
BOARD DIPLOMA EXAMINATIONS
C-23, EC-105, ELECTRONIC COMPONENTS AND POWER SUPPLIES
FIRST YEAR
YEAR END EXAMINATION

TIME:3 HOURS

MAX MARKS:80

Part-A

10×3=30

Instructions: (1) Answer all questions.
(2) Each question carries three marks
(3) Answer should be brief and straight to the point and shall not exceed five simple sentences.

1. Define the term capacitance (CO1)
2. Compare the features of carbon and wire wound potentiometers (CO1)
3. Sketch the I.S.I symbols of any three switches. (CO1)
4. Distinguish between Drift and Diffusion currents (CO2)
5. Compare Avalanche & Zener breakdown (CO2)
6. Relate alpha, beta and gamma Factors. (CO3)
7. Interpret the advantages of JFET over BJT. (CO3)
8. Write any three applications of photo diode? (CO4)
9. List any three materials used for the construction of LED (CO4)
10. List any three specifications of loud speakers. (CO5)

Part-B

5×10=50

Instructions: (1) Answer any 5 questions.
(2) Each question carries 10 marks
(3) Answer should be comprehensive and the criterion for valuation is the content but not the length of the answer.

11. Explain the use of Ferrites in the construction of high frequency inductors (CO1)
12. Explain the working of general-purpose electromagnetic relay and mention its applications. (CO1)
13. Explain the formation of P type and N-type semiconductors (CO2)
14. Explain the working of PN junction Diode with forward & reverse biasing. (CO2)
15. Explain the working of NPN and PNP transistors. (CO3)
16. Explain the construction and principle of operation of n channel JFET. (CO3)
17. Explain the construction, operation and characteristics of photo diode. (CO4)
18. Explain the working of dynamic microphone with its polar characteristics. (CO5)

ELEMENTS OF ELECTRICAL ENGINEERING

Course Code	Course title	No of periods/week	Total no of periods	Marks for FA	Marks for SA
EC-106	ELEMENTS OF ELECTRICAL ENGINEERING	05	150	20	80

S No	Unit Title	No. of Periods	COs Mapped
1	Basics of Electrical Engineering	25	CO1
2	Basic Electrical circuits	25	
3	AC Fundamentals	30	CO2
4	Transformers	20	CO3
5	Motors	17	
6	Measuring and Test Instruments	18	CO4
7	Batteries	15	CO5
Total		150	

Course Objectives	1. To understand the concepts of basic electrical circuits
	2. To understand the AC fundamentals
	3. To learn the practical importance and applications of Transformers Motors, Measuring instruments, Testing Instruments and batteries

CO No		COURSE OUTCOMES
CO1	EC-106.1	Explain the concept of electric field and magnetic field.
		Understand the concept of basic electrical circuits
CO2	EC-106.2	Analyse the AC fundamentals
CO3	EC-106.3	Explain the transformer principle and applications.
		Understand the basic principle of DC and AC motors
CO4	EC-106.4	Explain the construction and working principle of measuring and test instruments
CO5	EC-106.5	To understand the construction and working of different batteries

CO-PO/PSO MATRIX

CO No	PO1	PO2	PO3	PO4	PO5	PO6	PO7	PSO1	PSO2	PSO3
EC-106.1	3	2						3	1	
EC-106.2	3	3						3	1	
EC-106.3	3	1	3		3			3		1
EC-106.4	3	2	3	3	1			3	1	1
EC-106.5	3	2	3		1			3	1	
Average	3	2	3	3	1.67			3	1	1

3=strongly mapped 2=moderately mapped 1=slightly mapped

LEARNING OUTCOMES

1.0 Basics of Electrical Engineering

- 1.1 Explain the concept of lines of force & magnetic Field
- 1.2 Define the terms magnetic field intensity, magnetic potential, Flux, magnetic flux density
- 1.3 Define the terms absolute permeability and relative permeability
- 1.4 State Faraday's laws of electro - magnetic induction
- 1.5 Explain dynamically and statically induced E.M.F.
- 1.6 Define the term self-inductance, mutual inductance and co-efficient of coupling.
- 1.7 i) State expression for equivalent inductance of inductors connected in series
ii) State expression for equivalent inductance of inductors connected in parallel
- 1.8 Solve simple problems on the above
- 1.9 Explain the concept of electrostatic field
- 1.10 Define the terms absolute permittivity and relative permittivity
- 1.11 Define the terms electric potential and potential difference, voltage, current and power.
- 1.12 Define the terms electric field intensity, electric flux, electric flux density
- 1.13 i) State expression for equivalent capacitance of capacitors connected in series
ii) State expression for equivalent capacitance of capacitors connected in parallel
- 1.14 Solve simple problems on the above
- 1.15 Explain charging and discharging of capacitor

2.0 Basic Electrical circuits

- 2.1 Distinguish between active and passive elements
- 2.2 Explain the terms Ideal voltage source and Ideal current source
- 2.3 State Ohm's Law and its limitations
- 2.4 State Kirchhoff's current law and Kirchhoff's voltage law
- 2.5 Derive an expression for equivalent resistance of resistors connected in series
- 2.6 Derive an expression for equivalent resistance of resistors connected in parallel
- 2.7 Explain current division rule for a two branch parallel resistive network
- 2.8 Solve simple problems on current division rule

3.0 AC fundamentals

- 3.1 Explain the effect of AC flowing through Pure Resistance , Inductance and Capacitance with vector diagrams
- 3.2 Explain mathematical representation of vectors in a) symbolic notation b) trigonometric c) exponential and polar forms
- 3.3 Define the terms reactance, Impedance, admittance, conductance and power factor
- 3.4 Explain active and reactive components of AC current
- 3.5 Explain active, reactive and apparent power in AC circuit
- 3.6 Define Q factor of a coil
- 3.7 Explain series RL, RC and RLC circuits
- 3.8 Solve problems on series RL and RC circuits
- 3.9 Explain parallel RL, RC and RLC circuits

3.10 Explain admittance method for solving parallel RL, RC and RLC circuits

4.0 Transformers

- 4.1 Explain the working principle of transformer
- 4.2 Classify transformers based on power rating, construction and applications
- 4.3 Give reasons for using laminations in transformer core
- 4.4 State voltage transformation ratio
- 4.5 Explain the losses in a transformer
- 4.6 Define efficiency and regulation of transformer
- 4.7 Explain the construction and working of an auto transformer
- 4.8 Explain the applications of transformer as
 - a) potential transformer
 - b) current transformer
 - c) impedance matching transformer
 - d) isolation transformer
- 4.9 List important specifications of a transformer

5.0 Motors

- 5.1 Explain the principle of operation of DC Motor
- 5.2 Explain the significance of back EMF
- 5.3 State the equations for speed of
 - a) DC series motor b) DC shunt motor
- 5.4 Compare DC series motor and DC shunt motor
- 5.5 List specifications of DC motor
- 5.6 Explain the need for starter
- 5.7 Explain the principle of operation of single-phase induction motor
- 5.8 Explain the principle of operation of stepper motor
- 5.9 List the applications of stepper motor

6.0 Measuring and Test Instruments

- 6.1 List the characteristics of ideal voltmeter and ideal Ammeter.
- 6.2 Explain the construction and principle of operation of PMMC instrument.
- 6.3 Explain the working of rectifier type voltmeter
- 6.4 List the advantages of digital instruments over analog instruments.
- 6.5 Explain the working of Ramp type digital voltmeter with block diagram.
- 6.6 State the use of analog/digital multimeters.
- 6.7 State the specifications of digital multimeters such as Accuracy, Resolution, Range, Precision, Display Digits
- 6.8 Explain the working of function generator with block diagram.

7.0 Batteries

- 7.1 Define the terms 'Cell' and 'battery'
- 7.2 State the differences between Cells and Batteries.
- 7.3 Classify different types of batteries.
- 7.4 Explain the construction and working of sealed Lead Acid battery

- 7.5 List the advantages, limitations and applications of Lead acid batteries.
- 7.6 Explain the working Principle of Nickel-cadmium (Ni-Cd) batteries
- 7.7 List the advantages, limitations and applications of Ni-Cd Batteries.
- 7.8 Explain the construction and working of lithium-ion batteries
- 7.9 List the applications of Lithium-ion batteries.
- 7.10 State the important technical specifications of batteries.

COURSE CONTENT

1.0 Basics of Electrical Engineering

Concept of lines of force & magnetic Field –Magnetic field intensity, Magnetic potential, Flux , Magnetic Flux density - Absolute permeability and relative permeability - Faraday’s laws of electro - magnetic induction - Dynamically and statically induced E.M.F.- Self inductance ,mutual inductance and co-efficient of coupling- Equivalent inductance of inductors connected in series/parallel– Simple problems – Electrostatic field- Absolute permittivity and relative permittivity-Electric potential, potential difference, voltage, current and power- Electric field intensity – Electric flux – Electric flux density - Equivalent capacitance of capacitors connected in series/parallel - Simple problems - Charging and discharging of capacitor

2.0 Basic Electrical circuits

Active and passive elements-Ideal voltage source and Ideal current source- Ohm’s Law – Limitations - Kirchhoff’s current law and Kirchhoff’s voltage law-Equivalent resistance of resistors connected in series/parallel- Current division rule for a two branch parallel resistive network –Simple problems

3.0 AC fundamentals

Effect of AC flowing through Pure Resistance , Inductance and Capacitance with vector diagrams-Mathematical representation of vectors a) symbolic notation ,b) trigonometric c) exponential and polar forms - Reactance, Impedance, admittance, conductance and Power Factor- Active and Reactive components of AC current- Active and Reactive and apparent power - Q factor of a coil –Series RL,RC,RLC circuits with AC supply - AC through RL-RC circuits-problems on RL,RC circuits-Parallel AC circuit containing RLC- Admittance method for solving AC parallel circuits.

4.0 Transformers

Principle of transformer –Classifications-Reasons for using laminations- Voltage transformation ratio-Losses in transformer- Efficiency and regulation of transformer - Auto transformer- Applications of transformer-Specifications of transformer

5.0 Motors

Principle of D.C. motors- Significance of back E.M.F.- Equation for speed of DC motors(Series & Shunt) - Specifications of DC motor–Starter-Single phase induction motor, - Stepper motor

6.0 Measuring and Test Instruments

Characteristics of ideal voltmeter and ideal Ammeter - Construction and principle of operation of PMMC instrument-Rectifier type voltmeter-Advantages of digital instruments over analog instruments- Ramp type digital voltmeter – multimeter-specifications of digital multimeter - Function generator.

7.0 Batteries

Battery- Classification of batteries-Sealed Lead Acid battery- Nickel-cadmium (Ni-Cd) batteries- lithium-ion batteries- advantages, limitations and applications of different batteries-technical specifications of batteries

REFERENCEBOOKS

1. V K mehata, RohitMehata, Basic electrical engineering-S.Chand Publication
2. D P Kothari, I J Nagrath, Basic electrical engineering, 4th edition- TMH
3. B.L. Thereja, A Text Book of Electrical Technology volume –II -S.Chand
4. Dr.P S Bimbhra, Electrical Machines- Khanna Publication
5. HS Kalsi, Electronic Instrumentation, Tata McGraw Hill
6. T R Crompton, "Battery Reference Book-3 rd. Edition", Newness- Reed Educational and Professional Publishing Ltd.,

BLUE PRINT

SI No	Unit Title	No of Periods	Weightage Allotted	Weightage of Marks		COs mapped
				No of Essay Questions	No of Short answer Questions	
1	Basics of Electrical Engineering	25	16	1	2	CO1
2	Basic Electrical circuits	25	16	1	2	CO1
3	AC Fundamentals	30	23	2	1	CO2
4	Transformers	20	16	1	2	CO3
5	Motors	17	13	1	1	CO3
6	Measuring and Test Instruments	18	13	1	1	CO4
7	Batteries	15	13	1	1	CO5
		150	110	80	30	

Table specifying the scope of syllabus to be covered for Unit Tests

Unit Test	Learning outcomes to be covered
Unit Test-I	From 1.1 to 2.8
Unit Test-II	From 3.1 to 4.9
Unit Test-III	From 5.1 to 7.10

(Model Paper)

C –23, EC -106

State Board of Technical Education and Training, A. P
Diploma in Electronics and Communication Engineering (DECE)

First Year

Subject Name: Elements of Electrical Engineering

Sub Code: EC - 106

Time : 90 minutes

Unit Test- I

Max.Marks:40

Part-A

16Marks

Instructions: (1) Answer **all** questions.

(2) First question carries **four**marks, each question of remaining carries **three** marks

1. Fill in the blanks with one word
 - a) The work done to move a charge from infinite to the given point is called as _____ (CO1)
 - b) The permittivity of space is also called as _____ (CO1)
 - c) What are the units for magnetic flux density _____ (CO1)
 - d) What is the unit of capacitance _____ (CO1)
2. State Ohm's Law and it's limitations (CO1)
3. Define the terms Absolute and relative permittivity of a medium. (CO1)
4. Give the expression for equivalent capacitance of capacitors connected in parallel(CO1)
5. State Kirchhoff's current law and Kirchhoff's voltage law. (CO1)

Part-B

3×8=24

Instructions: (1) Answer **all** questions.

(2) Each question carries **eight** marks

(3) Answer should be comprehensive and the criterion for valuation is the content but not the length of the answer.

6. (a) Explain dynamically and statically induced E.M.F (CO1)
(or)
(b) Explain charging and discharging of capacitor (CO1)
7. (a) Explain current division rule for a two branch parallel resistive network (CO1)
(or)
(b) Explain the terms Ideal voltage source and Ideal current source (CO1)
8. (a) Explain the concept of lines of force & magnetic Field. (CO1)
(or)
(b) Derive an expression for equivalent resistance of resistors connected in series. (CO1)

-oOo-

(Model Paper)
State Board of Technical Education and Training, A. P
Diploma in Electronics and Communication Engineering (DECE)
First Year

C -23, EC -106

Subject Name: Elements of Electrical Engineering

Sub Code: EC - 106

Time : 90 minutes

Unit Test - II

Max.Marks:40

Part-A

16Marks

Instructions: (1) Answer **all** questions.
(2) First question carries **four** marks, each question of remaining carries **three** marks

1. a) In series RLC circuit at resonance the impedance is maximum. **(State True/False) (CO2)**
b) In parallel RLC circuit at resonance the impedance is maximum **(State True/False) (CO2)**
c) The Efficiency of the transformer is defined as the ratio of useful output power to the input power .**(TRUE/FALSE) (CO3)**
d)_____ of the transformer is the percentage change in the output voltage from no- load to full-load **(CO3)**
2. Define Q factor of a coil **(CO2)**
3. Define the terms reactance, Impedance **(CO2)**
4. State voltage transformation ratio of transformer. **(CO3)**
5. Classify transformers based on construction **(CO3)**

Part-B

3×8=24

Instructions: (1) Answer **all** questions.
(2) Each question carries **eight** marks
(3) Answer should be comprehensive and the criterion for valuation is the content but not the length of the answer.

6. (a) Explain the effect of AC flowing through Pure Resistance , inductance with vector diagrams **(CO2)**

(or)

- (b) Explain the effect of AC flowing through the series RC circuit with vector diagrams. **(CO2)**

7. (a) Explain mathematical representation of vectors in i) symbolic notation , ii) trigonometric and iii) polar forms **(CO2)**

(or)

- (b) Explain active, reactive and apparent power in AC circuit **(CO2)**

8. (a) Explain the losses in a transformer **(CO3)**

(or)

- (b) Explain the construction and working of an auto transformer **(CO3)**

-oOo-

(Model Paper)

C –23, EC -106

State Board of Technical Education and Training, A. P
Diploma in Electronics and Communication Engineering (DECE)
First Year

Subject Name: Elements of Electrical Engineering

Sub Code: EC - 106

Time : 90 minutes

Unit Test III

Max.Marks:40

Part-A

16Marks

- Instructions:** (1) Answer **all** questions.
(2) First question carries **four** marks, each question of remaining carries **three** marks

1. Fill in the blanks with one word
 - a) Write the equation for speed of DC series motor _____ (CO3)
 - b) Write the equation for speed of DC shunt motor _____ (CO3)
 - c) An ideal volt meter has infinite resistance. **TRUE /FALSE** (CO4)
 - d) In Ni-Cd cells the electrolyte is a mixture of deionized water and _____ (CO5)
2. Compare DC series motor and DC shunt motor (CO3)
3. List the advantages of digital instruments over analog instruments. (CO4)
4. State the differences between Cells and Batteries. (CO5)
5. List the limitations of Lead-acid batteries. (CO5)

Part-B

3×8=24

- Instructions:** (1) Answer **all** questions.
(2) Each question carries **eight** marks
(3) Answer should be comprehensive and the criterion for valuation is the content but not the length of the answer.

6. (a) Explain the principle of operation of single phase induction motor (CO3)
or
(b) Explain the principle of operation of stepper motor (CO3)
7. (a) Explain the construction and principle of operation of PMMC instrument. (CO4)
(or)
(b) Explain the working of function generator with block diagram. (CO4)
8. (a) Explain the construction and working of sealed Lead Acid battery? (CO5)
(or)
(b) Explain the construction and working of lithium-ion batteries? (CO5)

-o0o-

MODEL PAPER
BOARD DIPLOMA EXAMINATIONS
C-23, EC-106, ELEMENTS OF ELECTRICAL ENGINEERING
FIRST YEAR
END EXAMINATION

TIME:3 HOURS

MAX MARKS:80

Part-A

3×10=30

Instructions: (1) Answer **all** questions.
(2) Each question carries **three** marks
(3) Answer should be brief and straight to the point and shall not exceed five simple sentences.

1. Define the terms Absolute and relative permeability of medium. (CO1)
2. State Faraday's laws of electro - magnetic induction. (CO1)
3. State Ohm's law and its limitations. (CO1)
4. State Kirchoff's current law and Kirchoff's voltage law (CO1)
5. Define Q factor of a coil. (CO2)
6. Define efficiency and regulation of transformer (CO3)
7. State voltage transformation ratio (CO3)
8. Distinguish DC series motor and DC shunt motor (CO3)
9. List any three advantages of digital instruments over analog instruments. (CO4)
10. List the applications of Lead acid batteries. (CO5)

Part-B

5×10=50

Instructions: (1) Answer **any Five** questions.
(2) Each question carries **ten** marks
(3) Answer should be comprehensive and the criterion for valuation is the content but not the length of the answer.

11. Explain dynamically and statically induced E.M.F (CO1)
12. Explain current division rule for a two branch parallel resistive network (CO1)
13. Explain active, reactive and apparent power in AC circuit (CO2)
14. A series RC circuit with $R=100\ \Omega$, $C=56\ \mu\text{F}$ is connected across 230V,50Hz AC supply. Find (i) Impedance (ii) Current (iii) Power factor (iv) Voltage drop across the resistor (CO2)
15. Explain the construction and working of an auto transformer. (CO3)
16. Explain the principle of operation of stepper motor (CO3)
17. Explain the working of function generator with block diagram. (CO4)
18. Explain the construction and working of lithium-ion batteries? (CO5)

-o0o-

ENGINEERING DRAWING

Course code	Course Title	No. of periods /week	Total No. of periods	Marks for FA	Marks for SA
EC-107	ENGINEERING DRAWING	3	90	40	60

S.No	Unit Title	No. of periods	CO's Mapped
1	Use of Drawing Instruments, Free Hand Lettering and Dimensioning Practice	10	CO1
2	Principles of Geometric Constructions	15	CO2
3	Projections of points, lines, planes and solids	20	CO3
4	Sectional Views	20	CO4
5	Orthographic projection	25	CO5
	Total	90	

Course Objectives and Course Outcomes

Course Objectives	Upon completion of the course the student shall be able to understand the basic graphic skills and use them in preparation, reading and interpretation of engineering drawings.
--------------------------	---

Course Outcomes	CO1	EC-107.1	Practice the use of engineering drawing instruments and Familiarise with the conventions to be followed in engineering drawing as per BIS
	CO2	EC-107.2	Construct the i) basic geometrical constructions ii) engineering curves
	CO3	EC-107.3	Visualise and draw the projections of i) Points ii) Lines iii) Regular Planes iv) Regular Solids
	CO4	EC-107.4	Visualise and draw the sectional views of components
	CO5	EC-107.5	Visualise and draw the orthographic projections of components

PO-CO Mapping

EC-107	PO1	PO2	PO3	PO4	PO5	PO6	PO7	PSO1	PSO2	PSO3
CO1	3	2	2		1		1	2	3	1
CO2	3	2	2			2	1	2	3	1
CO3	3	2	2	1	1		1	2	3	1
CO4	3	2	2	1		2	1	2	3	1
CO5	3	2	2	1	1	2	1	2	3	1
AVERAGE	3	3	3	1	1	2	1	2	3	1

3: High, 2: Moderate, 1: Low

LEARNING OUTCOMES

Upon completion of the course the student shall able to

1.0 Use of Drawing Instruments, Free Hand Lettering and Dimensioning Practice

- 1.1 State the importance of drawing as an engineering communication medium
- 1.2 Select the correct instruments to draw the different lines / curves.
- 1.3 Use correct grade of pencil and other instruments to draw different types of lines and for different purposes
- 1.4 Identify the steps to be taken to keep the drawing clean and tidy.
- 1.5 Write titles using vertical and slopping (inclined) lettering and numerals of 7mm, 10mm and 14mm height.
- 1.6 Acquaint with the conventions, notations, rules and methods of dimensioning in engineering drawing as per the B.I.S.
- 1.7 Dimension a given drawing using standard notations and desired system of dimensioning.

2.0 Principles of Geometric Constructions

- 2.1 Practice the basic geometric constructions like i) dividing a line into equal parts
i) Exterior and interior tangents to the given two circles
ii) Tangent arcs to two given lines and arcs
- 2.2 Draw any regular polygon using general method when i) side length is given
i) Inscribing circle radius is given ii) describing circle radius is given
- 2.3 Draw the engineering curves like i) involute ii) cycloid

3.0 Projections of points, lines, planes and solids (All in first quadrant only)

- 3.1 Explain the basic principles of the orthographic projections
- 3.2 Visualise and draw the projection of a point with respect to reference planes (HP & VP)
- 3.3 Visualise and draw the projections of straight lines with respect to two reference Planes (up to lines parallel to one plane and inclined to other plane)
- 3.4 Visualise and draw the projections of planes (up to planes perpendicular to one plane and inclined to other plane)
- 3.5 Visualise and draw the projections of regular solids like Prisms, Pyramids, Cylinder, Cone (up to axis of solids parallel to one plane and inclined to other plane)

4.0 Sectional Views

- 4.1 Identify the need to draw sectional views.
- 4.2 Draw sectional views of regular solids by applying the principles of hatching.

5.0 Orthographic projection

5.1 Draw the orthographic views of an object from its pictorial drawing.

5.2 Draw the minimum number of views needed to represent a given object fully.

Competencies and Key competencies to be achieved by the student

S.No	Major topic	Key Competency
1.	Use of Drawing Instruments, Free Hand Lettering and Dimensioning Practice	<ul style="list-style-type: none"> • Explain the linkages between Engineering drawing and other subjects of study in Diploma course.
		<ul style="list-style-type: none"> • Select the correct instruments to draw various entities in different orientation
		<ul style="list-style-type: none"> • Write titles using sloping and vertical lettering and numerals as per B.I.S (Bureau of Indian standards)
		<ul style="list-style-type: none"> • Dimension a given drawing using standard notations and desired system of dimensioning
2.	Geometrical construction	<ul style="list-style-type: none"> • Dividing a line into equal parts, tangents to circles, Construct involute, cycloid from the given data.
3.	Projection of points, Lines, Planes & Solids	<ul style="list-style-type: none"> • Draw the projections of points, straight lines, planes & solids with respect to reference planes (HP& VP)
4.	Sectional Views	<ul style="list-style-type: none"> • Differentiate between true shape and apparent shape of section • Apply principles of hatching. • Draw simple sections of regular solids
5.	Orthographic Projection	<ul style="list-style-type: none"> • Draw the minimum number of views needed to represent a given object fully.

COURSE CONTENTS:

- NOTES:
1. B.I.S Specification should invariably be followed in all the topics.
 2. A-3 Size Drawing Sheets are to be used for all Drawing Practice Exercises.

1.0 Use of Drawing Instruments, Free Hand Lettering and Dimensioning Practice

Explanation of the scope and objectives of the subject of Engineering Drawing . Its importance as a graphic communication -Need for preparing drawing as per standards – SP-46 –1988 – Mention B.I.S - Role of drawing in -engineering education - Basic Tools, tools for drawing– Mentioning of names under each classification and their brief description -Scales: Recommended scales reduced & enlarged -Lines: Types of lines, selection of line thickness - Selection of Pencils -Sheet Sizes: A0, A1, A2, A3, A4, A5, Layout of drawing sheets in respect of

A0, A1, A3 sizes, Sizes of the Title block and its contents - Care and maintenance of Drawing Sheet,

Importance of lettering – Types of lettering -Guide Lines for Lettering Practicing of letters & numbers of given sizes (7mm, 10mm and 14mm)-Advantages of single stroke or simple style of lettering - Use of lettering stencils- Purpose of engineering Drawing, Need of B.I.S code in dimensioning -Shape description of an Engineering object -Definition of Dimensioning size description -Location of features, surface finish, fully dimensioned Drawing -Notations or tools of dimensioning, dimension line extension line, leader line, arrows, symbols, number and notes, rules to be observed in the use of above tools -Placing dimensions: Aligned system and unidirectional system (SP-46-1988)-Arrangement of dimensions Chain, parallel, combined progressive, and dimensioning by co-ordinate methods-The rules for dimensioning standard, features “Circles (holes) arcs, angles, tapers, chamfers, and dimension of narrow spaces.

2.0 Geometric Constructions

Division of a straight line into given number of equal parts –Drawing interior and exterior tangents to two circles of given radii and centre distance-Drawing tangent arc of given radius to touch two lines inclined at given angle (acute, right and obtuse angles), Tangent arc of given radius touching a circle or an arc and a given line, Tangent arcs of radius R, touching two given circles internally and externally-Construction of any regular polygon by general method for given side length, inscribing circle radius and describing/superscripting circle radius - Involute, Cycloid, explanations as locus of a moving point, their engineering application, viz., Gear tooth profile, screw threads, springs etc. – their construction

3.0 Projection of points, lines and planes and Solids (All in first quadrant only)

Classification of projections, Observer, Object, Projectors, Projection, Reference Planes, Reference Line, Various angles of projections –Differences between first angle and third angle Projections of points -Projections of straight line –(a) Parallel to both the planes, (b)Perpendicular to one of the planes and (c) Inclined to one plane and parallel to other planes-Projections of regular planes-(a) Plane parallel to one of the reference planes, (b) Plane perpendicular to HP and inclined to VP and vice versa- Projections of regular solids- (a) Axis perpendicular to one of the planes, (b) Axis parallel to VP and inclined to HP and vice versa.

4.0 Sectional Views

Need for drawing sectional views – what is a sectional view - Hatching – Section of regular solids inclined to one plane and parallel to other plane

5.0 Orthographic Projections

Meaning of orthographic projection - Using a viewing box and a model – Number of views obtained on the six faces of the box, - Legible sketches of only 3 views for describing object - Concept of front view, top view, and side view sketching these views for a number of engineering objects - Explanation of first angle projection. – Positioning of three views in First angle projection -Projection of points as a means of locating the corners of the surfaces of an

object – Use of meter line in drawing a third view when other two views are given -Method of representing hidden lines -Selection of minimum number of views to describe an object fully.

REFERENCE BOOKS

- 1 Engineering Graphics by P I Varghese – (McGraw-hill)
- 2 Engineering Drawing by Basant Agarwal & C.M Agarwal - (McGraw-hill)
- 3 Engineering Drawing by N.D.Bhatt.
- 4 T.S.M. & S.S.M on “ Technical Drawing” prepared by T.T.T.I., Madras.
- 5 SP-46-1998 – Bureau of Indian Standards.

Table specifying syllabus to be covered for UNIT TEST I, II and III.

Unit Test	Learning Outcomes to be Covered
Unit Test – I	From 1.1 to 2.3
Unit Test – II	From 3.1 to 3.5
Unit Test – III	From 4.1 to 5.2

Blue Print

S.No	Unit Title	No. of Periods	Weightage Allocated	Marks wise distribution of weightage			Question wise distribution of weightage			CO'S Mapped
				R	U	AP	R	U	AP	
1	Use of Drawing Instruments, Free Hand Lettering and Dimensioning Practice	10	10	05	05	00	01	01	00	CO1
2	Principles of Geometric Constructions	15	15	00	00	15	00	00	02	CO2
3	Projections of points, lines, planes and solids	20	25	00	00	25	00	00	03	CO3
4	Sectional Views	20	10	00	00	10	00	00	01	CO4
5	Orthographic projection	25	20	00	00	20	00	00	02	CO5
Total		90	80	05	05	70	01	01	08	

UNIT TEST-I, C-23, I YEAR, EC-107

ENGINEERING DRAWING

TIME:90 MINUTES

MAX MARKS: 40

PART-A

(4X5=20)

Instructions :

(1) Answer all questions. (2) Each question carries five marks. (3) All dimensions are in mm.

1. Write the following using single-stroke capital inclined letters of 14mm size **CO1**

“ALL THE BEST FOR YOUR EXAMINATION”

2. The component and its dimensions are shown in the fig. below. Redraw it to a full scale adopting the recommendations of SP : 46–1988. **CO1**

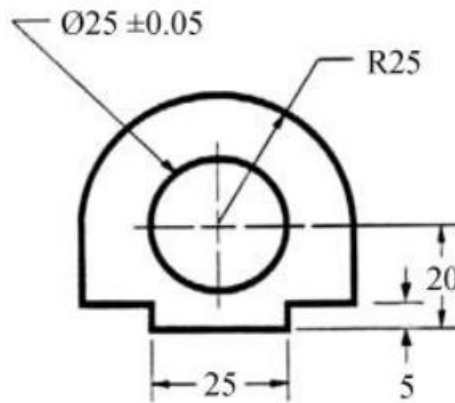

3. Divide a line of length 60 mm into seven equal parts. **CO2**

- 4.. Construct regular pentagon of side 25 mm by any one method. **CO2**

PART-B

(2X10=20)

5. . Draw an internal common tangent to two circles of radii 30 mm and 20 mm. **CO2**

6. . A circle of 50 mm diameter rolls along a line for one revolution clock wise. Draw the locus of a point on the circumference of circle which is in contact with the line. **CO2**

7. Draw an involute to a circle of radius 20 mm. **CO2**

8. Draw a helix of pitch 60 mm on a cylinder of diameter of 50 mm. **CO2**

UNIT TEST-II, C-23, 1st YEAR, EC-107, ENGINEERING DRAWING

TIME:90 MINUTES

MAX MARKS: 40

PART-A

(4X5=20M)

Answer all questions and each question carries four marks.

1. A point A is lying at 30 mm behind V.P and 60 mm below H.P. Draw its projections. **CO3**
2. A 60 mm long line pq has an end p at 20 mm above the H.P. and 30 mm in front of the VP. The line is inclined at 45° to the HP. And 30° to the VP. Draw its projections. **CO3**
3. A circular plane of diameter 60 mm is touching the VP with a point on its circumference. The plane is inclined at 45° to VP and perpendicular to HP. The centre of the plane is 40 mm above HP. Draw its projections. **CO3**
4. A square prism 40 mm base side and height 60 mm is standing vertically on its square base 10 mm above HP and one of its rectangular faces making an angle of 60° with V.P. Draw its projections. **CO3**

PART-B

(2X10=20 M)

Answer any two questions and Each question carries ten marks

5. A pentagonal lamina of side 25 mm rest on the HP on one of its edges, such that the surface is inclined at 45° to the HP, and the edge on which it rests is inclined at 60° to the VP. Draw its projections **CO3**
6. A rectangular plane ABCD of size 40mm X 30mm is inclined to the HP at 30° . Its shorter side AB is parallel to HP and inclined at 45° to VP. Draw its projections. **CO3**
7. A hexagonal pyramid of base side 25 mm and height 60 mm is standing on HP with one of its base edges making an angle of 60° with VP and axis making an angle of 45° with HP. Draw its projection. **CO3**
8. Draw the projections of a cone , base 30mm diameter and axis 50mm long resting on HP on a point of its base circle with the axis making an angle 45° with HP and parallel to VP. **CO3**

**UNIT TEST-III, C-23, 1st YEAR, EC-107,
ENGINEERING DRAWING**

TIME:90 MINUTES

MAX MARKS: 40

PART-A

(4X5=20M)

Answer all questions and each question carries four marks.

1. A triangular prism with a base side of 50 mm and height 70 mm is resting on one of its rectangular faces on HP with the axis perpendicular to VP. The prism is cut by a horizontal section plane passing through the axis. Draw front view and sectional top view of the prism. **CO4**
2. A square pyramid of base side 50mm and axis 75 mm long is resting on the ground with its axis vertical and sides of the base equally inclined to the VP. It is cut by a section plane perpendicular to VP inclined at 45° to HP and bisecting the axis. Draw its sectional top view. **CO4**
3. Draw the front view and top view of the following figure : **CO5**

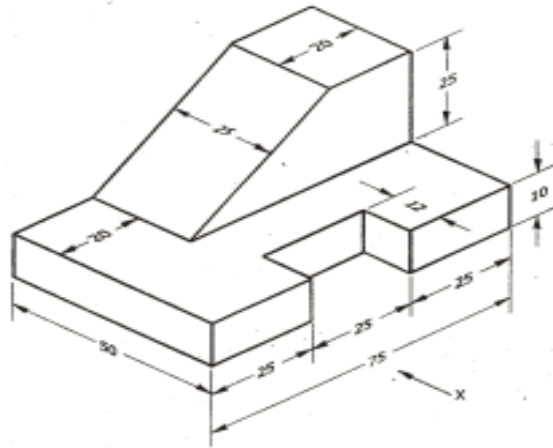

4. Draw the front view and top view of the following figure **CO5**

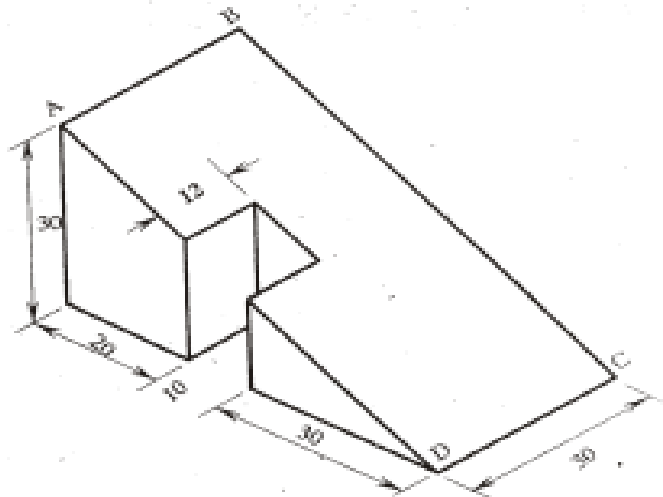

PART-B

(2X10=20 M)

Answer any Two questions, Each question carries ten marks.

1. A pentagonal pyramid of base side 40 mm and height 80mm is resting on HP on its base with one of its base side parallel to VP. It is cut by a plane inclined at 30° to HP, perpendicular to VP and is bisecting the axis. Draw its front view, sectional top view and the true shape of section. **CO4**
2. A cone of diameter 60 mm and height 70 mm is resting on ground on its base. It is cut by a section plane perpendicular to VP inclined at 45° to HP and cutting the axis at a point 40 mm from the bottom. Draw the front view , sectional top view and true shape. **CO4**

7. Draw the front view, side view and top view of the following figure: **CO5**

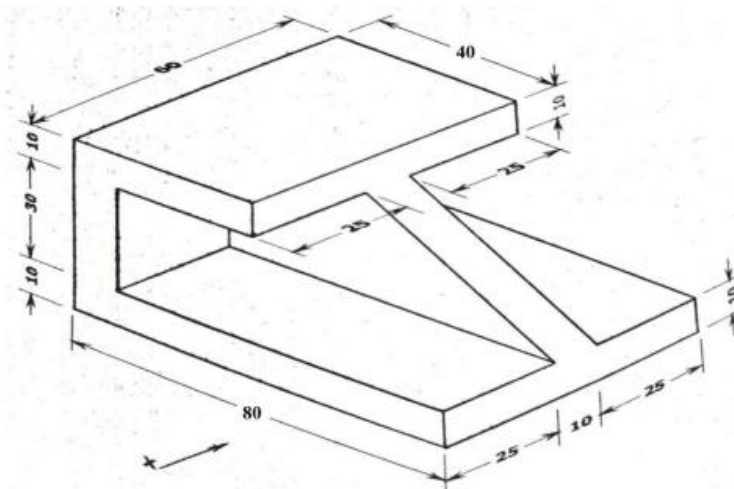

8. Draw orthographic views of front view and top view of the given isometric figure below. **CO5**

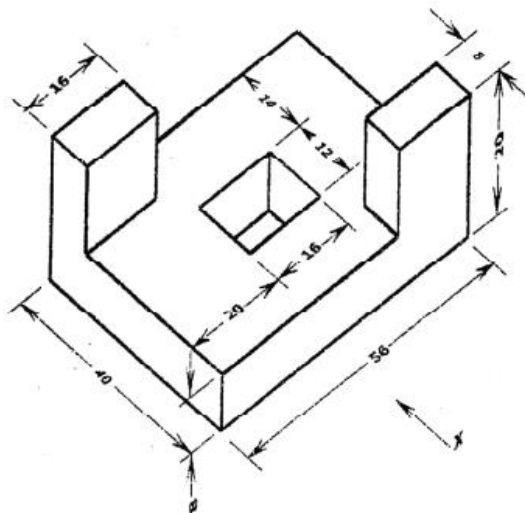

**BOARD DIPLOMA EXAMINATIONS
MODEL QUESTION PAPER
DECE – I-YEAR
EC-107 :: ENGINEERING DRAWING**

Time: 3 hours

Total Marks: 60

- Instructions:**
- i. All the dimensions are in mm
 - ii. Use first angle projections only
 - iii. Due weightage will be given for the dimensioning and neatness

PART – A

05 x 04=20

- i. Answer all the questions
 - ii. Each question carries FIVE marks
1. Write the following in single stroke capital vertical lettering of size 10mm

ORTHOGRAPHIC PROJECTIONS
 2. Redraw the given fig. and dimension it according to SP-46:1988. Assume suitable scale

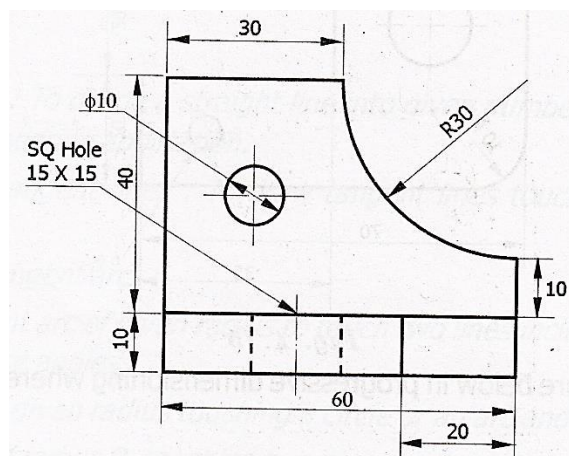

3. Draw internal common tangents to two unequal circles of radii 26mm and 20mm. The distance between the circles is 75mm.
4. Draw the projections of a point A lying on HP and 25mm in front of V.P.

Electronic Components and Devices Lab

Course Code	Course title	No of periods/week	Total no of periods	Marks for FA	Marks for SA
EC-108	Electronic Components and Devices Lab	03	90	40	60

S No	Unit Title	No. of Periods	COs Mapped
1	Identifying different electronic components	06	CO1
2	Soldering practice and Preparation of PCB	24	CO2
3	Study and use of Electronic equipment	21	CO3
4	Testing, obtaining characteristics of electronic devices	33	CO4
5	PA system	06	CO5
	Total	90	

Course Objectives	To have hands on practice on Soldering, de-soldering of circuits
	To have practice on preparation of PCB for given circuits
	To get acquainted with the usage of electronic equipment
	To test electronic devices and obtain their characteristics
	To arrange PA system with different loudspeakers and microphones

CO No		COURSE OUTCOMES
CO1	EC-108.1	Practice on Soldering, de-soldering of circuits and
CO2	EC-108.2	Preparation of PCB for given circuits
CO3	EC-108.3	Operating different electronic equipment
CO4	EC-108.4	Plot the characteristics of electronic devices
CO5	EC-108.5	Familiarise with PA system

CO-PO/PSO MATRIX

CO No	PO1	PO2	PO3	PO4	PO5	PO6	PO7	PSO1	PSO2	PSO3
EC-108.1	3		2	2	2		2	3		2
EC-108.2	3	2	2	2	2		2	3	2	1
EC-108.3	3	2	2	3				3	2	
EC-108.4	3	2	2	2				3	2	
EC-108.5	3		2	2	3			3	2	
Average	3	2	1	2.25	2.5	2		3	2	2

3=strongly mapped 2=moderately mapped 1=slightly mapped

LEARNING OUTCOMES:

1.0 Identify different Electronic Components and devices

- a) Identify the components, its terminals, and test :
 - i) colour coded resistors, different fixed and variable type resistors, different Inductors- different types of capacitors: ceramic, disc, paper, mica, gang etc.
 - ii) different SMD resistors, SMD inductors, SMD capacitors
 - iii) Diodes, Transistors, JFETs, MOSFETs
 - iv) Relays, Switches –SPST,SPDT,DPST,DPDT- Toggle-Push button –Rotary-Slider –Thumb Wheel
 - v) Diode, transistor & IC's SMD packages (SOT,PLCC),
 - vi) Different LEDs-Red LED, Blue LED, Green LED, Bi colour LED, Infrared LED, different sizes and forms, their specifications
- b) Familiarise with
 - i) Bread Board
 - ii) bridge rectifier as a device,
 - iii)DC to DC (Ex: 12V to 5V) converter as a device,
 - iv) temperature controlled Soldering station,
 - v) programmable Regulated power supply

2.0 Soldering practice and Preparation of PCB

- a) Familiarise with Temperature controlled Soldering Station
- b) Technique of using soldering iron, Soldering different components and ICs
- c) Soldering components on to general purpose PCB as per the given circuit diagram
- d) Technique of de-soldering using de-soldering pump and wick.
- e) Draw PCB for simple circuits and etch them on to a copper clad sheet
- f) Preparing PCB for the given circuit

3.0 Study and use of Electronic equipment

- a) Study of AC/DC voltmeter, AC/DC ammeter, ohm meter, Analog multimeter, Digital Multi meter.
- b) Study of RPS unit, CRO, Function Generator using their manuals and familiarise with the operation of each equipment.
- c) i) Measure Resistance using multimeter and compare with the calculated value using the colour code.
ii) Measure L and C using digital LCR meter and compare with the calculated value using the code.

4.0 Testing and obtaining characteristics of electronic devices

- a) Identify and test PN junction diode, Zener diode, LED, BJT and FET using multi meter
- b) i) Obtain VI characteristics of PN junction diode
ii) Obtain VI characteristics of Zener diode
- c) Obtain i/p and o/p characteristics of a transistor in CE configurations
- d) Obtain VI characteristics of photo diode

- e) Obtain the VI characteristics of Photo transistor
- f) Obtain VI characteristics of LDR
- g) Control a load using relay
 - i) Turn On and Off DC load (LED/Buzzer/DC motor)
 - ii) Turn On and Off AC load (Bulb/Tube light/Fan)
- h) Obtain drain characteristics of JFET

5.0 Testing of Loudspeakers and arranging PA system

- a) Measure the input impedance of Loud Speakers
- b) Arrange PA system with multi speakers and microphones (with cord and cordless)

-000-

ENGINEERING PHYSICS LAB
(C-23 curriculum common to all Branches)

Course code	Course Title	No. of Periods per week	Total No. of Periods	Marks for FA	Marks for SA
EC-109	ENGINEERING PHYSICS LAB	3	45	20	30

TIME SCHEDULE

S.No	List of experiments	No. of Periods	COs
1.	Vernier calipers	03	CO1
2.	Micrometer (Screw gauge)	03	
3.	Verification of Lami's theorem using concurrent forces	03	
4.	Determination of g using simple pendulum	03	CO2
5.	Focal length and power of convex lens	03	
6.	Refractive index of solid using travelling microscope	03	
7.	Verification of Boyle's law using Quill tube	03	CO3
8	Determination of pole strength of the bar magnet through magnetic field lines	03	
9	Resonance apparatus – Determination of velocity of sound in air	03	
10	Meter bridge – Determination of resistance and specific resistance of a wire	03	CO4
11	Verification of Newton's law of cooling	03	
12	Photo electric cell – Study of its characteristics	03	

Course Objectives	(1) To provide strong practical knowledge of Physics to serve as a tool for various device applications in Engineering. (2) To enhance scientific skills of the students by incorporating new experiments so as to enrich the technical expertise of the students as required for industries.
--------------------------	--

COURSE OUTCOMES:

CO1	Improving accuracy in various measurements; understanding the nature of the forces keeping the body in equilibrium.
CO2	Estimating the acceleration caused by the gravity of earth; Practical study of the concepts of refraction of light at curved/plane surface
CO3	Understanding the pressure of the gas as function of its volume; study of the combined magnetic field of the earth and an artificial magnet to estimate its pole strength; Estimating the velocity of sound in air through resonance phenomenon.
CO4	Applying Kirchoff's laws to evaluate the specific resistance of a wire; Study of exchange of heat from system to surrounding by graphical analysis; Conversion of light to micro currents as potential engineering application.

COs-POs mapping strength (as per given table)

	PO1	PO2	PO3	PO4	PO5	PO6	PO7	PSO1	PSO2	PSO3
CO1	3	2	2	2	2	1	2	3	2	2
CO2	2	3		2	2			1		
CO3	2	3		2	2			1		
CO4	2	3		2	2			1		
Average	2	3		2	2			1		

3=strongly mapped 2= moderately mapped 1= slightly mapped

LEARNING OUTCOMES:

Upon completion of the course the student shall be able to

- 1.0 Practise with Vernier calipers to determine the volumes of a cylinder and sphere..
- 2.0 Practise with Screw gauge to determine thickness of a glass plate and cross sectional area of a wire.
- 3.0 Verify the Lami's theorem using concurrent forces.
- 4.0 Determine the value of acceleration due to gravity using Simple Pendulum. To verify the result from $l-T^2$ graph.
- 5.0 Calculate the Focal length and focal power of convex lens using distant object method, U-V method, U-V graph and $1/U - 1/V$ graph methods.
- 6.0 Determine the refractive index of a solid using travelling microscope
- 7.0 Verify the Boyle's law using Quill tube. To draw a graph between P and $1/l$.
- 8.0 Determination of magnetic pole strength of a bar magnet by drawing magnetic lines of force and locating null points (either N-N or N-S method)
- 9.0 Determine the velocity of sound in air at room temperature and its value at zero degree centigrade.
- 10.0 Determine the resistance and specific resistance of material of a wire using Meter Bridge
- 11.0 To verify the Newton's law of cooling.
- 12.0 To study the characteristics of photo electric cell.

CHEMISTRY LABORATORY
(C-23 curriculum common to all Branches)

Course code	Course Title	No. of Periods per week	Total No. of Periods	Marks for FA	Marks for SA
EC-110	CHEMISTRY LABORATORY	3	45	20	30

CO1	Operate and practice volumetric apparatus and preparation of standard solution
CO2	Evaluate and judge the neutralization point in acid base titration
CO3	Evaluate the end point of reduction and oxidation reaction
CO4	Judge the stable end point of complex formation, stable precipitation
CO5	Judge operate and demonstrate and perform precise operations with instrument for investigation of water pollution parameters

PO- CO mapping

Course code EC-110	Chemistry Laboratory No of COs:5				No Of periods 45
POs	Mapped with CO No	CO periods addressing PO in Col 1 NO %		Level 1,2,3	remarks
PO1	CO1,CO2,CO3, CO4,CO5	12	26.66	2	>40% level 3 (highly addressed) 25% to 40% level2(moderately addressed 5% to 25% level1 (Low addressed < 5%(not addressed)
PO2	CO1,CO2,CO3, CO4,CO5	9	20	1	
PO3					
PO4	CO1,CO2,CO3, CO4,CO5	12	26.66	2	
PO5	CO2,CO3, CO4,CO5	12	26.66	2	
PO6					
PO7					

COs-POs mapping strength (as per given table)

	PO1	PO2	PO3	PO4	PO5	PO6	PO7	PSO1	PSO2	PSO3
CO1	2	3		2				1		
CO2	2	3		2	2			1		
CO3	2	3		2	2			1		
CO4	2	3		2	2			1		
CO5	2	3		2	2			1		
Average	2	3		2	2			1		

3=strongly mapped 2= moderately mapped 1= slightly mapped

Note: The gaps in CO and PO mapping will be achieved by one or more appropriate activities

from the following: i) Seminars ii) Tutorials iii) Guest Lectures iv) Assignments v) Quiz competitions vi) Industrial visit vii) Tech Fest viii) Mini project ix) Group discussions x) Virtual classes xi) Library visit for e-books

TIMESCHEDULE

S.No	Name of the Experiment	No. of Periods	Mapped with COs
1.	a) Recognition of chemical substances and solutions used in the laboratory by senses. b) Familiarization of methods for Volumetric analysis	03	CO1
2.	Preparation of Std Na_2CO_3 and making solutions of different dilution solution.	03	CO1
3.	Estimation of HCl solution using Std. Na_2CO_3 solution	03	CO2
4.	Estimation of NaOH using Std. HCl solution	03	CO2
5	Determination of acidity of water sample	03	CO2
6	Determination of alkalinity of water sample	03	CO2
7.	Estimation of Mohr's Salt using Std. KMnO_4	03	CO3
8.	Estimation of Ferrous ion by using Std. $\text{K}_2\text{Cr}_2\text{O}_7$	03	CO3
9.	Determination of total hardness of water using Std. EDTA	03	CO4
10.	Estimation of Chlorides present in water sample	03	CO4
11.	Estimation of Dissolved Oxygen(D.O)in water sample	03	CO5
12.	Determination of pH using pH meter	03	CO5
13	Determination of conductivity of water and adjusting ionic strength required level.	03	CO5
14.	Determination of turbidity of water	03	CO5
15.	Estimation of total solids present in water sample	03	CO5
	Total:	45	

LEARNING OUTCOMES:

- 1.0 Practice volumetric measurements (using pipettes, measuring jars, volumetric flask, burettes) and gravimetric measurements (using different types of balances), making dilutions, etc. To identify the chemical compounds and solutions by senses.
- 2.0 Practice making standard solutions with pre weighed salts and to make solutions of desired dilutions using appropriate techniques.
- 3.0 Conduct titrations adopting standard procedures and using Std. Na_2CO_3 solution for estimation of HCl
- 4.0 Conduct titrations adopting standard procedures and using Std. HCl solution for estimation of NaOH
- 5.0 Conduct titrations adopting standard procedures to determine the acidity of given samples

- of water (One ground water and one surface / tap water, and rain water if available)
- 6.0 Conduct titrations adopting standard procedures to determine the alkalinity of given samples of water (One ground water and one surface / tap water)
 - 7.0 Conduct titrations adopting standard procedures and using Std.KMnO₄ solution for estimation of Mohr's Salt
 - 8.0 Conduct titrations adopting standard procedures and using Std.K₂Cr₂O₇ solution for estimation of Ferrous ion.
 - 9.0 Conduct titrations adopting standard procedures to determine the total hardness of given samples of water (One ground water and one surface / tap water) using Std. EDTA solution
 - 10.0 Conduct titrations adopting standard procedures to determine the chlorides present in the given samples of water and wastewater (One ground water and one surface / tap water)
 - 11.0 Conduct the test using titrometric / electrometric method to determine Dissolved Oxygen (D.O) in given water samples (One sample from closed container and one from open container / tap water)
 - 12.0 Conduct the test on given samples of water / solutions (like soft drinks, sewage, etc.) to determine their pH using standard pH meter
 - 13.0 Conduct the test on given samples of water / solutions
 - a) To determine conductivity
 - b) To adjust the ionic strength of the sample to the desired value
 - 14.0 Conduct the test on given samples of solutions (coloured and non- coloured) to determine their turbidity in NTU
 - 15.0 To determine the total solids present in given samples of water (One ground water and one surface / tap water)

Competencies and Key competencies to be achieved by the student

Name of the Experiment (No of Periods)	Competencies	Key competencies
Familiarization of methods for Volumetric analysis. Recognition of chemical substances And	-	--
Preparation of Std Na ₂ CO ₃ and making solutions of different dilution(03)	<ul style="list-style-type: none"> ▪ Weighing the salt to the accuracy of .01 mg ▪ Measuring the water with volumetric flask, measuring jar, volumetric pipette and graduated pipette ▪ Making appropriate dilutions 	<ul style="list-style-type: none"> ▪ Weighing the salt to the accuracy of .01 mg ▪ Measuring the water with volumetric flask, measuring jar, volumetric pipette and graduated pipette ▪ Making appropriate dilutions
Estimation of HCl solution using Std. Na ₂ CO ₃ solution (03)	<ul style="list-style-type: none"> ▪ Cleaning the glassware and rinsing with appropriate solutions 	<ul style="list-style-type: none"> ▪ Making standard solutions ▪ Measuring accurately the standard solutions and titrants
Estimation of NaOH using Std.HCl solution (03)	<ul style="list-style-type: none"> ▪ Making standard solutions ▪ Measuring accurately the 	<ul style="list-style-type: none"> ▪ Effectively Controlling the

Determination of acidity of water sample (03)	standard solutions and titrants <ul style="list-style-type: none"> ▪ Filling the burette with titrant ▪ Fixing the burette to the stand ▪ Effectively Controlling the flow of the titrant ▪ Identifying the end point ▪ Making accurate observations ▪ Calculating the results 	flow of the titrant <ul style="list-style-type: none"> ▪ Identifying the end point ▪ Making accurate observations
Determination of alkalinity of water sample (03)		
Estimation of Mohr's Salt using Std.KMnO ₄ (03)		
Estimation of Ferrous ion by using Std.K ₂ Cr ₂ O ₇ (03)		
Determination of total hardness of water using Std.EDTA solution (03)		
Estimation of Chlorides present in water sample (03)		
Estimation of Dissolved Oxygen(D.O) in water sample (By titration method) (03)		
Determination of pH using pH meter (03)	<ul style="list-style-type: none"> ▪ Familiarize with instrument ▪ Choose appropriate 'Mode' / 'Unit' ▪ Prepare standard solutions / buffers, etc. ▪ Standardize the instrument with appropriate standard solutions ▪ Plot the standard curve 	<ul style="list-style-type: none"> ▪ Prepare standard solutions / buffers, etc. ▪ Standardize the instrument with appropriate standard solutions ▪ Plot the standard curve ▪ Make measurements accurately
Determination of conductivity of water and adjusting ionic strength to required level (03)		
Determination of turbidity of water (03)		
Estimation of total solids present in water sample (03)		

SCHEME OF VALUATION

A) Writing Chemicals, apparatus ,principle and procedure	5M
B) Demonstrated competencies	20M
Making standard solutions	
Measuring accurately the standard solutions and titrants	
Effectively controlling the flow of the titrant	
Identifying the end point	
Making accurate observations	
C) Viva-voce	5M
Total	30M

COMPUTER FUNDAMENTALS LABORATORY
(C-23 curriculum common to all Branches)

Course code	Course Title	No. of Periods/Weeks	Total No. of periods	Marks for FA	Marks for SA
EC-111 (common to all branches)	Computer Fundamentals Lab	3	90	40	60

Time schedule:

S.No.	Chapter/Unit Title	No. of sessions each of 3 periods duration	No.of Periods
1.	Computer hardware Basics	2	6
2.	Windows Operating System	2	6
3.	MS Word	8	24
4.	MS Excel	7	21
5.	MS PowerPoint	5	15
6.	Adobe Photoshop	6	18
Total periods		30	90

S.No.	Chapter/Unit Title	No.of Periods	CO's Mapped
1.	Computer hardware Basics	6	CO1
2.	Windows Operating System	6	CO1
3.	MS Word	24	CO2
4.	MS Excel	21	CO3
5.	MS PowerPoint	15	CO4
6.	Adobe Photoshop	18	CO5
Total periods		90	

Course Objectives	i)To know Hardware Basics ii)To familiarize operating systems iii)To use MS Office effectively to enable to students use these skills in future courses iv) To use Adobe Photoshop in image editing.
--------------------------	---

Course Outcomes	At the end of the course students will be able to		
	CO1	EC-111.1	Identify hardware and software components
	CO2	EC-111.2	Prepare documents with given specifications using word processing software
	CO3	EC-111.3	Use Spread sheet software to make calculation and to draw various graphs / charts.
	CO4	EC-111.4	Use Power point software to develop effective presentation for a given theme or topic.
CO5	EC-111.5	Edit digital or scanned images using Photoshop	

CO-PO/PSO MATRIX

CO NO.	PO1	PO2	PO3	PO4	PO5	PO6	PO7	PSO1	PSO2	PSO3
EC-111.1	3	3	3	3	3	3	3	3	2	3
EC-111.2	3	3	3	3	3	3	3	3	2	3
EC-111.3	3	3	3	3	3	3	3	3	2	3
EC-111.4	3	3	3	3	3	3	3	3	2	3
EC-111.5	3	3	3	3	3	3	3	3	2	3
Average	3	3	3	3	3	3	3	3	2	3

3=Strongly mapped , 2=moderately mapped, 1=slightly mapped

Learning Outcomes:**I. Computer Hardware Basics**

1. a) To Familiarize with Computer system and hardware connections
b) To Start and Shut down Computer correctly
c) To check the software details of the computer
2. To check the hardware present in your computer

II. Windows's operating system

3. To Explore Windows Desktop
4. Working with Files and Folders
5. Windows Accessories: Calculator – Notepad – WordPad – MS Paint

III. Practice with MS-WORD

6. To familiarize with Ribbon layout of MS Word
Home – Insert- Page layout – References – Review- View.
7. To practice Word Processing Basics
8. To practice Formatting techniques
9. To insert a table of required number of rows and columns
10. To insert Objects, Clipart and Hyperlinks
11. To use Mail Merge feature of MS Word
12. To use Equations and symbols features

IV. Practice with MS-EXCEL

13. To familiarize with MS-EXCEL layout
14. To access and enter data in the cells
15. To edit a spread sheet- Copy, Cut, Paste, and selecting Cells
16. To use built in functions and Formatting Data
17. To create Excel Functions, Filling Cells
18. To enter a Formula for automatic calculations
19. To sort and filter data in table.
20. To present data using Excel Graphs and Charts.
21. To develop lab reports of respective discipline.

22. To format a Worksheet in Excel, Page Setup and Print

V. Practice with MS-POWERPOINT

- 23. To familiarize with Ribbon layout features of PowerPoint 2007.
- 24. To create a simple PowerPoint Presentation
- 25. To set up a Master Slide in PowerPoint
- 26. To insert Text and Objects
- 27. To insert a Flow Charts
- 28. To insert a Table
- 29. To insert a Charts/Graphs
- 30. To insert video and audio
- 31. To practice Animating text and objects
- 32. To Review presentation

VI. Practice with Adobe Photoshop

- 33. To familiarize with standard toolbox
- 34. To edit a photograph.
- 35. To insert Borders around photograph.
- 36. To change Background of a Photograph.
- 37. To change colors of Photograph.
- 38. To prepare a cover page for the book in your subject area.
- 39. To adjust the brightness and contrast of the picture so that it gives an elegant look.
- 40. To type a word and apply the shadow emboss effects.

Key competencies:

Expt No	Name of Experiment	Competencies	Key competencies
1 (a).	To familiarize with Computer system and hardware connections	<ul style="list-style-type: none"> a. Identify the parts of a Computer system: i). CPU ii). Mother Board iii) Monitor iv) CD/DVD Drive v) Power Switch vi) Start Button vii) Reset Button b. Identify and connect various peripherals c. Identify and connect the cables used with computer system d. Identify various ports on CPU and connect Keyboard & Mouse 	Connect cables to external hardware and operate the computer
1 (b).	To Start and Shut down Computer correctly	<ul style="list-style-type: none"> a. Log in using the password b. Start and shut down the computer c. Use Mouse and Key Board 	<ul style="list-style-type: none"> a. Login and logout as per the standard procedure b. Operate mouse & Key Board
1 (c).	To Explore Windows Desktop	<ul style="list-style-type: none"> a. Familiarize with Start Menu, Taskbar, Icons and Shortcuts 	<ul style="list-style-type: none"> a. Access application programs using Start menu

		<ul style="list-style-type: none"> b. Access application programs using Start menu, Task manager c. Use Help support 	<ul style="list-style-type: none"> b. Use taskbar and Task manager
2.	To check the software details of the computer	<ul style="list-style-type: none"> a. Find the details of Operating System being used b. Find the details of Service Pack installed 	<ul style="list-style-type: none"> Access the properties of computer and find the details
3.	To check the hardware present in your computer	<ul style="list-style-type: none"> a. Find the CPU name and clock speed b. Find the details of RAM and Hard disk present c. Access Device manager using Control Panel and check the status of devices like mouse and key board d. Use My Computer to check the details of Hard drives and partitions e. Use the Taskbar 	<ul style="list-style-type: none"> a. Access device manager and find the details b. Type /Navigate the correct path and Select icon related to the details required
4.	Working with Files and Folders	<ul style="list-style-type: none"> a. Create folders and organizing files in different folders b. Use copy / paste move commands to organize files and folders 	<ul style="list-style-type: none"> a. Create files and folders Rename , arrange and search for the required folder/file
	Working with Files and Folders Continued....	<ul style="list-style-type: none"> c. Arrange icons – name wise, size, type, Modified d. Search a file or folder and find its path e. Create shortcut to files and folders (in other folders) on Desktop f. Familiarize with the use of My Documents g. Familiarize with the use of Recycle Bin 	<ul style="list-style-type: none"> b. Restore deleted files from Recycle bin

5.	To use Windows Accessories: Calculator – Notepad – WordPad – MS Paint	a.Familiarize with the use of Calculator b.Access Calculator using Run command c.Create Text Files using Notepad and WordPad and observe the difference in file size d.Use MS paint and create .jpeg, .bmp files using MS Paint	a. Use windows accessories and select correct text editor based on the situation. b. Use MS pain to create /Edit pictures and save in the required format.
6.	To familiarize with Ribbon layout of MS word. – Home – Insert- page layout- References-Review-View	a.Create/Open a document b.Use Save and Save as features c.Work on two Word documents simultaneously d.Choose correct Paper size and Printing options	a. Create a Document and name appropriately and save b. Set paper size and print options
7.	To practice Word Processing Basics	a.Typing text b.Keyboard usage c.Use mouse (Left click / Right click / Scroll) d.Use Keyboard shortcuts e.Use Find and Replace features in MS- word f. Use Undo and Redo Features g.Use spell check to correct Spellings and Grammar	a. Use key board and mouse to enter/edit text in the document. b. Use shortcuts c. Use spell check/ Grammar features for auto corrections.
8.	To practice Formatting techniques	a.Formatting Text b.Formatting Paragraphs c.Setting Tabs d.Formatting Pages e.The Styles of Word f. Insert bullets and numbers g.Themes and Templates h.Insert page numbers, header and footer	a. Format Text and paragraphs and use various text styles. b. Use bullets and numbers to create lists c. Use Templates /Themes d. Insert page numbers date, headers and footers
9.	To insert a table of required number of rows and columns	a.Edit the table by adding the fields – Deleting rows and columns –inserting sub table – marking borders. Merging and splitting of cells in a Table b.Changing the background colour of the table c. Use table design tools	a. Insert table in the word document and edit b. Use sort option for arranging data.

		<p>d. Use auto fit – fixed row/ column height/length – Even distribution of rows / columns features</p> <p>e. Convert Text to table and Table to Text</p> <p>f. Use Sort feature of the Table to arrange data in ascending/descending order</p>	
10.	To Insert objects, clipart and Hyperlinks	<p>a. Create a 2-page document. & Insert hyperlinks and t Bookmarks.</p> <p>b. Create an organization chart</p> <p>c. Practice examples like preparing an Examination schedule notice with a hyperlink to Exam schedule table.</p>	<p>a. Insert hyperlinks & Bookmarks</p> <p>b. Create organization charts/flow charts</p>
11.	To Use Mail merge feature of MS Word	<p>a. Use mail merge to prepare individually addressed letters</p> <p>b. Use mail merge to print envelopes.</p>	Use Mail merge feature
12.	To use Equations and symbols features.	<p>a. Explore various symbols available in MS Word</p> <p>b. Insert a symbol in the text</p> <p>c. Insert mathematical equations in the document</p>	Enter Mathematical symbols and Equations in the word document
13.	To Practice with MS-EXCEL	<p>a. Open /create an MS Excel spreadsheet and familiarize with MS Excel 2007 layout like MS office Button-Title Bar- Ribbon-Worksheets-Formula Bar-Status Bar</p>	<p>a. Familiarize with excel layout and use</p> <p>b. Use various features available in toolbar</p>
14.	To access and Enter data in the cells	<p>a. Move Around a Worksheets- Quick access -Select Cells</p> <p>b. Enter Data-Edit a Cell-Wrap Text-Delete a Cell Entry-Save a File-Close Excel</p>	<p>a. Access and select the required cells by various addressing methods</p> <p>b. Enter data and edit</p>
15.	To edit spread sheet Copy, Cut, Paste, and selecting cells	<p>a. Insert and Delete Columns and Rows-Create Borders-Merge and Center</p> <p>b. Add Background Color-Change</p>	Format the excel sheet

		the Font, Font Size, and Font Color c. Format text with Bold, Italicize, and Underline-Work with Long Text-Change a Column's Width	
16.	To use built in functions and Formatting Data	a. Perform Mathematical Calculations verify -AutoSum b. Perform Automatic Calculations-Align Cell Entries	Use built in functions in Excel
17.	To enter a Formula for automatic calculations	a. Enter formula b. Use Cell References in Formulae c. Use Automatic updating function of Excel Formulae d. Use Mathematical Operators in Formulae e. Use Excel Error Message and Help	Enter formula for automatic calculations
18.	To Create Excel Functions, Filling Cells	a. Use Reference Operators b. Work with sum, Sum if , Count and Count If Functions c. Fill Cells Automatically	a. Create Excel sheets involving cross references and equations b. Use the advanced functions for conditional calculations
19.	To sort and filter data in table	a. Sort data in multiple columns b. Sort data in a row c. Sort data using Custom order d. Filter data in work sheet	a. Refine the data in a worksheet and keep it organized b. Narrow a worksheet by selecting specific choice
20.	To Practice Excel Graphs and Charts	a. Produce an Excel Pie Chart b. Produce c. Excel Column Chart	a. Use data in Excel sheet to Create technical charts and graphs Produce Excel Line Graph b. Produce a Pictograph in Excel
21.	To develop lab reports of respective discipline	Create Lab reports using MS Word and Excel	a. Insert Practical subject name in Header and page numbers in Footer
22.	To format a Worksheet in Excel, page setup and print	a. Shade alternate rows of data b. Add currency and percentage	a. Format Excel sheet b. Insert headers

		<ul style="list-style-type: none"> symbols c. Change height of a row and width of a column d. Change data alignment e. Insert Headers and Footers f. Set Print Options and Print 	&footers and print
23.	To familiarize with Ribbon layout & features of PowerPoint 2007.	<ul style="list-style-type: none"> Use various options in PowerPoint a. Home b. Insert c. Design d. Animation e. Slideshow f. View g. Review 	Access required options in the tool bar
24.	To create a simple PowerPoint Presentation	<ul style="list-style-type: none"> a. Insert a New Slide into PowerPoint b. Change the Title of a PowerPoint Slide c. PowerPoint Bullets d. Add an Image to a PowerPoint Slide e. Add a Textbox to a PowerPoint slide 	<ul style="list-style-type: none"> a. Create simple PowerPoint presentation with photographs/ClipArt and text boxes b. Use bullets option
25.	To Set up a Master Slide in PowerPoint and add notes	<ul style="list-style-type: none"> a. Create a PowerPoint Design Template b. Modify themes c. Switch between Slide master view and Normal view d. Format a Design Template Master Slide e. Add a Title Slide to a Design Template f. The Slide Show Footer in PowerPoint g. Add Notes to a PowerPoint Presentation 	<ul style="list-style-type: none"> a. Setup Master slide and format b. Add notes
26.	To Insert Text and Objects	<ul style="list-style-type: none"> a. Insert Text and objects b. Set Indents and line spacing c. Insert pictures/ clipart d. Format pictures e. Insert shapes and word art f. Use 3d features g. Arrange objects 	<ul style="list-style-type: none"> Insert Text and Objects Use 3d features
27.	To insert a Flow Chart / Organizational Charts	<ul style="list-style-type: none"> a. Create a Flow Chart in PowerPoint b. Group and Ungroup Shapes 	Create organizational charts and flow charts using smart art

		c. Use smart art	
28.	To insert a Table	a. PowerPoint Tables b. Format the Table Data c. Change Table Background d. Format Series Legend	Insert tables and format
29.	To insert a Charts/Graphs	a. Create 3D Bar Graphs in PowerPoint b. Work with the PowerPoint Datasheet c. Format a PowerPoint Chart Axis d. Format the Bars of a Chart e. Create PowerPoint Pie Charts f. Use Pie Chart Segments g. Create 2D Bar Charts in PowerPoint h. Format the 2D Chart e. Format a Chart Background	Create charts and Bar graphs, Pie Charts and format.
30.	To Insert audio & video, Hyperlinks in a slide Add narration to the slide	a. Insert sounds in the slide and hide the audio symbol b. Adjust the volume in the settings c. Insert video file in the format supported by PowerPoint in a slide d. Use automatic and on click options e. Add narration to the slide f. Insert Hyperlinks	a. Insert Sounds and Video in appropriate format. b. Add narration to the slide c. Use hyperlinks to switch to different slides and files
31.	To Practice Animation effects	a. Apply transitions to slides b. To explore and practice special animation effects like Entrance, Emphasis, Motion Paths & Exit	Add animation effects
32.	Reviewing presentation	a. Checking spelling and grammar b. Previewing presentation c. Set up slide show d. Set up resolution e. Exercise with Rehearse Timings feature in PowerPoint f. Use PowerPoint Pen Tool during slide show g. Saving h. Printing presentation (a) Slides (b) Hand-out	a. Use Spell check and Grammar feature b. Setup slide show c. Add timing to the slides d. Setup automatic slide show

33	To familiarize with standard toolbox	<ul style="list-style-type: none"> a. Open Adobe Photoshop b. Use various tools such as <ul style="list-style-type: none"> i. The Layer Tool ii. The Color & Swatches Tool iii. Custom Fonts & The Text Tool iv. Brush Tool v. The Select Tool vi. The Move Tool vii. The Zoom Tool viii. The Eraser ix. The Crop Tool x. The Fill Tool 	Open a photograph and save it in Photoshop
34	To edit a photograph	<ul style="list-style-type: none"> a. Use the Crop tool b. Trim edges c. Change the shape and size of a photo d. Remove the part of photograph including graphics and text 	a. Able to edit image by using corresponding tools.
35	To insert Borders around photograph	<ul style="list-style-type: none"> a. Start with a single background layer b. Bring the background forward c. Enlarge the canvas d. Create a border color e. Send the border color to the back f. Experiment with different colors 	Able to create a border or frame around an image to add visual interest to a photo
36	To change Background of a Photograph	<ul style="list-style-type: none"> a. open the foreground and background image b. Use different selection tools to paint over the image c. Copy background image and paste it on the foreground. 	Able to swap background elements using the Select and Mask tool and layers.

		<p>d. Resize and/or drag the background image to reposition.</p> <p>e. In the Layers panel, drag the background layer below the foreground image layer.</p>	
37	To change colors of Photograph	<p>a. Change colors using:</p> <p>i) Color Replacement tool</p> <p>ii) Hue/Saturation adjustment layer tool</p>	Able to control color saturation
38	To prepare a cover page for the book in subject area	<p>a. open a file with height 500 and width 400 for the cover page.</p> <p>b. apply two different colors to work area by dividing it into two parts using Rectangle tool.</p> <p>c. Copy any picture and place it on work area → resize it using free transform tool.</p> <p>d. Type text and apply color and style</p> <p>e. Apply effects using blended options</p>	Able to prepare cover page for the book
39	To adjust the brightness and contrast of picture to give an elegant look	<p>a. open a file.</p> <p>b. Go to image → adjustments → Brightness/Contrast.</p> <p>c. adjust the brightness and contrast.</p> <p>d. Save the image.</p>	Able to control brightness/contrast.
40	To type a word and apply the shadow emboss effects	<p>a. open a file</p> <p>b. Select the text tool and type text.</p> <p>c. Select the typed text go to layer → layer style → blended option → drop shadow, inner shadow, bevel and emboss → contour → satin → gradient overlay</p> <p>d. Save the image.</p>	Able to apply shadow emboss effects

Table specifying the scope of syllabus to be covered for unit tests

Unit Test	Learning outcomes to be covered
Unit test-1	From 1 to 8
Unit test-2	From 9 to 22
Unit test-3	From 23 to 40

Electrical Engineering Lab

Course Code	Course title	No of periods/week	Total no of periods	Marks for FA	Marks for SA
EC-112	Electrical Engineering Lab	03	90	40	60

S No	Unit Title	No. of Periods	COs Mapped
1	Safety precautions and cleaning	6	CO1
2	Electrical Wiring	30	CO2
3	Transformers, Series and parallel circuits, Verification of Ohms law, KCL and KVL	24	CO3
4	Measurement of electrical Quantities using CRO	15	CO4
5	Batteries	15	CO5
	Total	90	

Course Objectives	To apply safe working practices
	To get acquainted with the usage of different types of tools, wires, cables and electrical wiring
	To test transformers, verify Ohm's law, KCL and KVL
	To operate CRO and measure electrical quantities and to make battery connections

CO No	Course Outcomes
CO1	EC-112.1 Use different electrical safety accessories and practices
CO2	EC-112.2 Use different types of electric tools, wires, cables, prepare wire joints and practice electrical wiring.
CO3	EC-112.3 Test the working of given transformers, make series and parallel circuits and verify Ohm's law, KCL and KVL
CO4	EC-112.4 Operate CRO and measure electrical parameters using CRO
CO5	EC-112.5 Test the condition of battery and make series and parallel connection of batteries

CO-PO/PSO MATRIX

CO No	PO1	PO2	PO3	PO4	PO5	PO6	PO7	PSO1	PSO2	PSO3
EC-112.1	3			2	2			3		2
EC-112.2	3	2		3		2		3	2	
EC-112.3	3	2		3		2		3	2	
EC-112.4	3		1	1	3	2		3		2
EC-112.5	3	2	1	2	1	2		3		
Average	3	2	1	2	2	2		3	2	2

3=strongly mapped 2=moderately mapped 1=slightly mapped

LEARNING OUTCOMES:

1.0 Safety precautions and cleaning

1.1 Identify safety symbols and interpret what they mean with the help of their colour and shape

- 1.2 Practice and follow preventive safety rules to avoid electrical accidents.
- 1.3 Select fire extinguishers according to the type of the fire and operate the fire extinguisher to extinguish the fire.
- 1.4 Practice the disposal procedure of waste materials.

2.0 Electrical wiring

2.1 Identifying and working with the following tools used in Electrical Wiring

- i. Wire stripper
- ii. Insulation remover
- iii. Pocket knife
- iv. Electrical Tester
- v. Phillips Head Screwdrivers
- vi. Mallet
- vii. Raw plug jumper
- viii. Standard wire Gauge

2.2 Identifying and Working with Pliers

- a. Identify and Know the various functions of cutting pliers
 - i. Nose pliers
 - ii. Pipe pliers
 - iii. Flush cutter
 - iv. Top cutting pliers
 - v. Electronics pliers
 - vi. Insulated cutting pliers
- b. perform the following operations
 - i. Holding
 - ii. Wire cutting
 - iii. Component bending
 - iv. Twisting the wire

2.3 Identification of different wires and cables

- a. Identify Wires used for electrical wiring
 - i. Hook up wire
 - ii. Teflon wires
 - iii. Service wire
 - iv. TRS wires /PVC Wires (Al and Cu)
 - v. single strand
 - vi. Multi strand
 - vii. twisted Flexible pair wires
 - viii. Enamelled copper wire
 - ix. Power cord

b. Identify Cables used for communication

- i. UTP cable,
- ii. Co axial cables
- iii. Flat ribbon cable for antennas,
- iv. Telephone cable
- v. Ethernet cable
- vi. Ribbon cables
- vii. Optical fiber

2.4 Practice of wire joints

2.4.1 Make simple twist, married, Tee and western union joints

2.4.2 Make britannia straight, britannia 'T' (Tee) and rat tail joints

2.5 Identifying the Electrical accessories

- i. SPST Switch
- ii. SPDT switch
- iii. Two pin and 3pin Sockets and plugs
- iv. Power Socket
- v. Power plugs
- vi. Lamp holders
- vii. Ceiling rose
- viii. Mains Switch
- ix. MCB
- x. Kit-kat Fuse
- xi. Fuse wire ratings

2.6 Know the mains supply Phase, Neutral and Ground

2.6.1 identify Phase and Neutral terminals in mains supply

2.6.2 Study the purpose of earthing

2.6.3 Make 2pin and 3pin Plug connections

2.7 Make simple switch connections using low voltage transformer

2.7.1 Make and test a circuit with one 6V lamp controlled by a switch (toggle)

2.7.2 Make and Test 2-way light switch connections

2.7.3 Make Series and parallel connection of lamps

3.0 Series and Parallel circuits & Measurement of Electrical Quantities using CRO

3.1 Verify Ohm's law.

3.2 connect a series combination of three 1 k Ω resistors across 12V dc supply. Measure the current in the circuit and calculate equivalent resistance of the series connected resistors.

3.3 connect a parallel combination of two 1 k Ω resistors across 10V dc supply. Measure the current supplied by the source and calculate equivalent resistance of the parallel connected resistors.

3.4 Verify the Kirchhoff's current law (with two branch currents)

3.5 Verify the Kirchhoff's voltage Law (with one voltage source)

- 3.6 Identify the voltage rating, primary and secondary terminals of a given transformer and measure its secondary voltage and turns ratio by applying rated primary voltage.

4.0 Measurement of electrical parameters using CRO

- 4.1 Study the function of front panel controls of CRO
- 4.2 Measure DC voltage using CRO
- 4.3 Measure amplitude and Time period of a sinusoidal signal using CRO.

5.0 Batteries

- 5.1 Study different types of batteries
- 5.2 Identify the given batteries/ cells and test whether they are in good condition or not
- 5.3 Connect the given two batteries in series and measure the voltage across the series connection. What do you learn from the measured equivalent voltage and the voltage of each battery
- 5.4 Connect the given two batteries in parallel and measure the voltage across the parallel connection. What do you learn from the measured equivalent voltage and the voltage of each battery
- 5.5 Study various sections of Battery charger circuit

-0o0-

III SEMESTER

DIPLOMA IN ELECTRONICS & COMMUNICATION ENGINEERING
SCHEME OF INSTRUCTIONS AND EXAMINATIONS
III SEMESTER

Subject Code	Name of the Subject	Instruction period / week		Total Period / Sem	Scheme of Examination			
		Theory	Practical/ Tutorial		Duration (hours)	Sessional Marks	End Exam Marks	Total Marks
THEORY								
EC- 301	Engineering Mathematics - II	4	-	60	3	20	80	100
EC -302	Electronic Circuits - I	4	-	60	3	20	80	100
EC -303	Digital Electronics	4	-	60	3	20	80	100
EC-304	Analog and Digital Communication Systems	5	-	75	3	20	80	100
EC-305	Network Analysis	5	-	75	3	20	80	100
EC - 306	Programmng in C and MATLAB	4	-	60	3	20	80	100
PRACTICAL								
EC-307	Electronic Circuits-I & Network Analysis Lab	-	4	60	3	40	60	100
EC-308	Digital Electronics lab	-	3	45	3	40	60	100
EC-309	Analog and Digital Communication systems Lab	-	3	45	3	40	60	100
EC-310	Programmng in C and MATLAB Practice	-	3	45	3	40	60	100
	Activities		3	45	-	-	-	-
TOTAL		26	16	630	-	280	720	1000

C-23

ENGINEERING MATHEMATICS-II

Course Code	Course Title	No. of Periods/week	Total No. of periods	Marks for FA	Marks for SA
EC-301	Engineering Mathematics-II	4	60	20	80

S.No.	Unit Title	No. of periods	COs mapped
1	Indefinite Integration	20	CO1
2	Definite Integration and its applications	10	CO2
3	Differential Equations	13	CO3
4	Laplace Transforms & Fourier series	17	CO4
	Total Periods	60	

Course Objectives	<ul style="list-style-type: none"> (iii) To understand the concepts of indefinite integrals and definite integrals with applications to engineering problems. (iv) To understand the formation of differential equations and learn various methods of solving first order differential equations. (v) To learn the principles of solving homogeneous differential equations of second order. (vi) To comprehend and understand the concepts of Laplace transformations and Fourier series.
--------------------------	--

Course Outcomes	CO1	Integrate various functions using different methods.
	CO2	Evaluate definite integrals and learn its applications.
	CO3	Obtain differential equations and solve differential equations of first order and first degree. Solve homogeneous differential equations of second order.
	CO4	Find Laplace Transforms of various functions and expand the given functions as Fourier series.

C-23
ENGINEERING MATHEMATICS – II
Learning Outcomes
Unit-I

C.O. 1 Integrate various functions using different methods.

L.O.1.1. Explain the concept of Indefinite integral as an anti-derivative.

1.2. State the indefinite integral of standard functions and properties of $\int (u + v) dx$ and $\int k u dx$ where u, v are functions of x and k is constant.

1.3. Solve problems involving standard functions using the above rules.

1.4. Evaluate integrals involving simple functions of the following type by the method of substitution.

i) $\int f(ax + b) dx$, where $f(x)$ is in standard form.

ii) $\int (f(x))^n f'(x) dx$

iii) $\int [f'(x)/f(x)] dx$

iv) $\int [f(g(x))] g'(x) dx$

1.5. Find the integrals of $\tan x, \cot x, \sec x$ and $\operatorname{cosec} x$ using the above.

1.6. Evaluate the Standard integrals of the functions of the type

i) $\frac{1}{a^2 + x^2}, \frac{1}{a^2 - x^2}, \frac{1}{x^2 - a^2}$

ii) $\frac{1}{\sqrt{a^2 + x^2}}, \frac{1}{\sqrt{a^2 - x^2}}, \frac{1}{\sqrt{x^2 - a^2}}$

iii) $\sqrt{x^2 - a^2}, \sqrt{x^2 + a^2}, \sqrt{a^2 - x^2}$

1.7. Evaluate integrals using decomposition method.

1.8. Solve problems using integration by parts.

1.9 Use Bernoulli's rule for evaluating the integrals of the form $\int u.v dx$.

1.10. Evaluate the integrals of the form $\int e^x [f(x) + f'(x)] dx$

Unit-II

C.O.2 Evaluate definite integrals with applications.

L.O.2.1. State the fundamental theorem of integral calculus

- 2.2. Explain the concept of definite integral.
- 2.3. Solve simple problems on definite integrals over an interval using the above concept.
- 2.4. State various properties of definite integrals.
- 2.5. Evaluate simple problems on definite integrals using the above properties.
- 2.6. Find the area bounded by a curve and axes.
- 2.7. Obtain the mean and R.M.S values of the simple functions.

Syllabus for Unit test-I completed

Unit -III

C.O. 3 Form differential equations and solve differential equations of first order and first degree and Solve homogeneous differential equation of second order.

L.O.3.1. Define a Differential equation, its order and degree

- 3.2 Find order and degree of a given differential equation.
- 3.3 Form a differential equation by eliminating arbitrary constants.
- 3.4 Solve the first order and first degree differential equations by variables separable method.
- 3.5 Solve linear differential equation of the form $\frac{dy}{dx} + Py = Q$, where P and Q are functions of x or constants.
- 3.6 Solve Differential equations of the type $(aD^2 + bD + c)y = 0$ where a, b, c are real numbers and provide examples.

Unit-IV

Laplace transforms & Fourier series

C.O. 4 Find Laplace Transforms of various functions and expand the given functions as Fourier series.

- L.O.** 4.1 Define Laplace Transform and explain the sufficient conditions of existence of Laplace Transform
- 4.2. Obtain Laplace transforms of elementary functions and solve simple problems.
- 4.3 State linearity property, first shifting theorem of Laplace transforms (without proof) and solve simple problems.
- 4.4 Define Inverse Laplace Transform.
- 4.5 Obtain Inverse Laplace Transforms for standard functions and solve simple problems.
- 4.6 State linearity property, first shifting theorem of Inverse Laplace transforms (without proof) and solve simple problems.
- 4.7 Define orthogonality of functions in an interval.
- 4.8 Define Fourier series of a function in the interval $(c, c + 2\pi)$ and Euler's formulae for Fourier coefficients.
- 4.9 Write sufficient conditions for the existence of Fourier series expansion of a function in an interval.
- 4.10 Expand the functions $f(x) = k$ (constant) and $f(x) = x$ as Fourier series in the intervals $(0, 2\pi)$ and $(-\pi, \pi)$

Syllabus for Unit test-II completed

C-23

Engineering Mathematics – II

CO/PO – Mapping

	PO1	PO2	PO3	PO4	PO5	PO6	PO7	PSO1	PSO2	PSO3
CO1	3	2	2	2				3	1	2
CO2	3	3	3	3				3	3	3
CO3	3	3	3	3				3	3	3
CO4	3	3	3	3				3	3	3
Avg.	3	2.75	2.75	2.75				3	2.5	2.75

3 =Strongly mapped (High), **2** = Moderately mapped (Medium), **1** = Slightly mapped (Low)

PO5: Appropriate quiz programme may be conducted at intervals and duration as decided by concerned teacher.

PO6: Seminars on applications of mathematics in various engineering disciplines are to be planned and conducted.

PO7: Such activities are to be planned that students visit library to refer standard books on Mathematics and latest updates in reputed national and international journals, attending seminars, learning mathematical software tools.

PSO1: An ability to understand the concepts of basic mathematical techniques and to apply them in various areas like computer programming, civil constructions, fluid dynamics, electrical and electronic systems and all concerned engineering disciplines.

PSO2: An ability to solve the Engineering problems using latest software tools, along with analytical skills to arrive at faster and appropriate solutions.

PSO3: Wisdom of social and environmental awareness along with ethical responsibility to have a successful career as an engineer and to sustain passion and zeal for real world technological applications.

C-23
Engineering Mathematics – II
PO- CO – Mapping strength

PO no	Mapped with CO no	CO periods addressing PO in column I		Level (1,2 or 3)	Remarks
		Number	%		
1	CO1, CO2, CO3,CO4	60	100%	3	>40% Level 3 Highly addressed 25% to 40% Level 2 Moderately addressed 5% to 25% Level 1 Low addressed <5% Not addressed
2	CO1, CO2, CO3,CO4	60	100%	3	
3	CO1, CO2, CO3,CO4	60	100%	3	
4	CO2, CO3,CO4	38	63.3%	3	
5					
6					
7					
PSO 1	CO1, CO2, CO3,CO4	60	100%	3	
PSO 2	CO1, CO2, CO3,CO4	40	66.6%	3	
PSO 3	CO1, CO2, CO3,CO4	45	75%	3	

ENGINEERING MATHEMATICS – II

COURSE CONTENTS

Unit-I

Indefinite Integration:

1. Integration regarded as anti-derivative – Indefinite integrals of standard functions. Properties of indefinite integrals. Integration by substitution or change of variable. Integrals of $\tan x$, $\cot x$, $\sec x$, $\operatorname{cosec} x$.

Evaluation of integrals which are of the following forms:

$$\begin{aligned} \text{i)} & \frac{1}{a^2 + x^2}, \frac{1}{a^2 - x^2}, \frac{1}{x^2 - a^2} \\ \text{ii)} & \frac{1}{\sqrt{a^2 + x^2}}, \frac{1}{\sqrt{a^2 - x^2}}, \frac{1}{\sqrt{x^2 - a^2}} \\ \text{iii)} & \sqrt{x^2 - a^2}, \sqrt{x^2 + a^2}, \sqrt{a^2 - x^2} \end{aligned}$$

Integration by decomposition of the integrand into simple rational, algebraic functions.

Integration by parts, Bernoulli's rule and integrals of the form $\int e^x [f(x) + f'(x)] dx$.

Unit-II

Definite Integral and its applications:

2. Definite integral-fundamental theorem of integral calculus, properties of definite integrals, evaluation of simple definite integrals. Area bounded by a curve and axes. Mean and RMS values of a function on a given interval.

Unit -III

Differential Equations:

3. Definition of a differential equation-order and degree of a differential equation- formation of differential equations-solutions of differential equations of first order and first degree using methods: variables separable, linear differential equation of the type $\frac{dy}{dx} + Py = Q$. Solutions of homogenous linear differential equations of second order with constant coefficients.

Unit IV:

Laplace transforms & Fourier series

4. Definition, sufficient conditions for existence of Laplace Transform, LT of elementary functions, linearity property, state first shifting theorem with simple problems. Definition of Inverse Laplace

Transform, ILT of elementary functions, linearity property, first shifting theorem with simple problems.

5. Orthogonality of trigonometric functions, Representation of a function in Fourier series over the interval $(c, c + 2\pi)$, Euler's formulae, sufficient conditions for existence of Fourier series expansion of a function, Fourier series expansion of basic functions limited to k (constant), x over the intervals $(0, 2\pi), (-\pi, \pi)$.

Reference Books:

1. B. S. Grewal, Higher Engineering Mathematics, Khanna Publishers.
2. Schaum's Outlines Differential Equations, Richard Bronson & Gabriel B. Costa
3. M. R. Spiegel, Schaum's Outline of Laplace Transforms, Schaums' Series.
4. M. Vygodsky, Mathematical Handbook: Higher Mathematics, Mir Publishers, Moscow.

C- 23 Engineering Mathematics – II

Subject Title : Engineering Mathematics – II
 Subject Code : xx-301 (Common to all Branches)
 Periods/Week : 04
 Periods/Semester : 60

BLUE PRINT

S.No.	Chapter/Unit title	No. of Periods	Weightage Allotted	Short type			Essay type			COs mapped
				R	U	Ap	R	U	Ap	
Unit – I: Indefinite integration										
1	Indefinite integration	20	32	4	0	0	0	2	0	CO1
Unit – II: Definite Integration and its applications										
2	Definite Integrals	5	11	0	2	0	0	1/2	0	CO2
3	Area of curves	2	3	0	0	1	0	0	0	CO2
4	Mean and RMS values	3	8	0	0	1	0	1/2	0	CO2
Unit – III: Differential Equations										
5	Introduction to Differential Equations	5	3	0	1	0	0	0	0	CO3
6	Solution of first order differential equations	4	10	0	0	0	0	0	1	CO3
7	Solution of second order homogeneous differential equations	4	10	0	0	0	0	0	1	CO3
Unit - IV Laplace transforms & Fourier series										
8	Laplace Transforms	5	10	0	0	0	0	0	1	CO4
9	Inverse Laplace Transforms	5	10	0	0	0	0	0	1	CO4
10	Fourier Series	7	13	0	0	1	0	0	1	CO4
Total		60	110	4	3	3	0	3	5	
Marks				12	9	9	0	30	50	

R: Remembering Type :12 Marks
U: understanding Type :39 Marks
Ap: Application Type :59 Marks

C-23

Engineering Mathematics – II

Unit Test Syllabus

Unit Test	Syllabus
Unit Test-I	From L.O 1.1 to L.O 2.7
Unit Test-II	From L.O 3.1 to L.O 4.10

UNIT TEST MODEL PAPERS

C –23, XX-301

Unit Test I

State Board of Technical Education and Training, A. P

III SEM

Subject name: **Engineering Mathematics-II**

Sub Code: **xx-301**

Time: 90 minutes

Max. Marks: 40

Part-A

16 Marks

Instructions: (1) Answer **all** questions.

(2) First question carries **four** marks and the remaining questions carry **three** marks each.

1. Answer the following:

a. $\int x^6 dx = \dots$

(CO1)

b. $\int \frac{1}{16+x^2} dx = \dots$

(CO1)

c. $\int e^x (f(x) + f'(x)) dx = e^x f(x) + c$: State TRUE/FALSE

(CO1)

d. $\int_0^1 x dx = \dots$

(CO2)

2. Evaluate $\int (\sec^2 x + 2e^x) dx$.

(CO1)

3. Evaluate $\int \frac{\sin(\log x)}{x} dx$.

(CO1)

4. Evaluate $\int_0^{\frac{\pi}{2}} \cos x dx$

(CO2)

5. Evaluate $\int_0^{1/2} \frac{1}{\sqrt{1-x^2}} dx$ (CO2)

Part-B

3×8=24 Marks

Instructions: (1) Answer **all** questions. (2) Each question carries **eight** marks
 (3) Answer should be comprehensive and the criterion for valuation is the content but not the length of the answer.

6. A) Evaluate $\int \sin^4 x \cos x dx$. **or**
 (CO1)
 B) Evaluate $\int \frac{1}{(x+1)(x+2)} dx$. (CO1)
7. A) Evaluate $\int \sqrt{1-\sin 2x} dx$. **or**
 (CO1)
 B) Evaluate $\int x^2 e^{3x} dx$. (CO1)
8. A) Evaluate $\int_0^{\frac{\pi}{2}} \frac{\sin x}{\sin x + \cos x} dx$ **or** (CO2)
 B) Find the RMS value of $y = \sqrt{2x+3}$ between $x=1, x=2$. (CO2)

-oOo-

Unit Test II

C -23, XX -301

State Board of Technical Education and Training, A. P

III Sem

Subject name: **Engineering Mathematics-II**

Sub Code: **xx-301**

Time : 90 minutes

Max.marks:40

Part-A

16 Marks

Instructions: (1) Answer **all** questions.
 (2) First question carries **four** marks and the remaining questions carry **three** marks each

1. Answer the following:

- a. The order of the differential equation $\frac{d^3 y}{d x^3} + \frac{d^2 y}{d x^2} + y = 0$ is _____. (CO3)
- b. The auxiliary equation of the differential equation $\frac{d^2 y}{d x^2} + 2 \frac{d y}{d x} + y = 0$ is _____. (CO3)
- c. If $L\{f(t)\} = F(s)$, then $L\{e^{at} f(t)\} = F(s-a)$: State TRUE/FALSE (CO4)

- c. The formula for finding the coefficient a_0 in the Fourier series expansion of the function $f(x)$ in the interval $0 < x < 2\pi$ is _____ . (CO4)
2. Form the differential equation by eliminating the arbitrary constant m from $y = mx + 1$. (CO3)
3. Verify $y = \sin 3x$ is a solution of $y'' + y = 0$ (CO3)
4. Solve the differential equation $(D^2 - 9)y = 0$. (CO3)
5. Evaluate $L\{2 \cos t + 3 \sin t\}$ (CO4)

Part-B

3×8=24 Marks

Instructions: (1) Answer **all** questions. (2) Each question carries **eight** marks
 (3) Answer should be comprehensive and the criterion for valuation is the content but not the length of the answer.

- (CO2)
6. A) Solve $\frac{dy}{dx} + \frac{y}{x} = x^2$. or (CO3)
 B) Solve $(D^2 - 2D + 1)y = 0$. (CO3)
7. A) Evaluate $L\{3 \sin t + 4 \cos t - e^t + t^2\}$. or
 B) Evaluate $L^{-1}\{\frac{1}{s-3} + \frac{5}{s^2} - \frac{s}{s^2+4}\}$ (CO4)
8. Find the Fourier series for $f(x) = k$ in the interval $[0, 2\pi]$ or
 Find the Fourier series for $f(x) = x$ in the interval $(-\pi, \pi)$. (CO4)

-o0o-

Answer All questions. Each question carries THREE marks.

10x3=30M

11. Evaluate $\int (5^x + 5x)dx$. CO

1

12. Evaluate $\int (3x^2 + 2x + 5)dx$

13. Evaluate $\int (\sin 3x + \cos 2x)dx$. CO 1

14. Evaluate $\int (2x - 3)^8 dx$ CO

1

15. Evaluate $\int_0^1 (x^3 + 1)dx$ CO

2

16. Evaluate $\int_{-\frac{\pi}{2}}^{\frac{\pi}{2}} \sin x dx$ CO

2

17. Find the area bounded by the curve $y = x^2$, x-axis and the lines $x = 2$ and $x = 5$ CO2

18. Find the mean value of the function $f(x) = \frac{1}{1+x^2}$ in the interval $[0,1]$. CO

2

19. Find the order and degree of the differential equation $\frac{d^3y}{dx^3} + 3\frac{d^2y}{dx^2} + 5y = 0$. CO3

20. Write the Euler's formulae for finding Fourier coefficients of a function $f(x)$ over $[c, c + 2\pi]$ CO4

PART-B

Answer any FIVE questions. Each question carries TEN marks.

5x10=50M

11. (a) Evaluate $\int \left(\cos 5x + 4 \sec^2 x + 8e^{4x} + \frac{2}{x} \right) dx$. CO1

(b) Evaluate $\int \sqrt{1 + \sin 2\theta} d\theta$ CO1

12. (a) Evaluate $\int \frac{9}{\sqrt{25-x^2}} dx$ CO1

(b) Evaluate $\int \frac{1}{(x-1)(x+2)} dx$. CO1

13. (a) Evaluate $\int_0^{\frac{\pi}{2}} \frac{\cos x}{\sin x + \cos x} dx$ **CO2**
- (b) Find the R.M.S. value of the function $f(x) = \sqrt{\sin x}$ over the range $x = 0$ and $x = \pi$ **CO2**
14. Solve $\frac{dy}{dx} + y \tan x = \sec x$ **CO2**
15. (a) Solve $(D^2 - 4)y = 0$ **CO3**
- (b) Solve $(D^2 + 4D + 3)y = 0$. **CO3**
16. (a) Evaluate $L\{4e^{5t} + 6t^3 - 3\sin 4t + 2\cos 2t\}$. CO4
- (b) Evaluate $L\{e^{2t}t^3\}$ CO4
17. (a) Evaluate $L^{-1}\left\{\frac{1}{s-3} + \frac{5}{s^2} - \frac{s}{s^2+4}\right\}$ **CO4**
- (b) Evaluate $L^{-1}\left\{\frac{s-2}{(s-2)^2+9}\right\}$ **CO4**
18. Obtain Fourier series of $f(x) = x$ in the interval $(-\pi, \pi)$. **CO4**

-o0o-

ELECTRONIC CIRCUITS - I

Course Code	Course title	No of periods/week	Total no of periods	Marks for FA	Marks for SA
EC-302	ELECTRONIC CIRCUITS-I	04	60	20	80

S No	Unit Title	No. of Periods	COs Mapped
1	DC Power Supplies	12	CO1
2	Transistor Biasing and stabilization	8	CO2
3	Small Signal Amplifiers	10	CO3
5	Large Signal Amplifiers	10	CO4
6	Feedback amplifiers & Oscillators	20	CO5
	TOTAL	60	

Course Objectives	To understand different rectifier circuits and regulated power supplies
	To familiarize with various transistor biasing and stabilization circuits
	To understand different small signal, large signal amplifiers
	To explain different feedback amplifiers and oscillators

CO No	COURSE OUTCOMES
CO1	EC-302.1 Explain rectifier circuits and regulated power supplies
CO2	EC-302.2 Analyze the need of biasing and Stabilization techniques
CO3	EC-302.3 Explain the working of small signal amplifiers
CO4	EC-302.4 Describe various large signal amplifier circuits
CO5	EC-302.5 Explain the working of small signal amplifiers , feedback amplifiers Describe various oscillator circuits

CO-PO/PSO MATRIX

CO No	PO1	PO2	PO3	PO4	PO5	PO6	PO7	PSO1	PSO2	PSO3
EC-302.1	3	3	2	1				3	2	
EC-302.2	3	3	2	1	2			3		
EC-302.3	3	3	2	1	2			3		
EC-302.4	3	3	2	1	2			3	1	
EC-302.5	3	3	2	1	2			3		
Average	3	3	2	1	2			3	1.5	

3=strongly mapped 2=moderately mapped 1=slightly mapped

LEARNING OUTCOMES:

1.0 DC Power Supplies

- 1.1 Explain the necessity of D.C. power supply for Electronic circuits
- 1.2 Explain the working of Half wave rectifier, Full Wave centre tapped rectifier and Bridge rectifier circuits with wave forms
- 1.3 Write the equations for RMS value and average value(DC value) voltages and currents for above rectifiers(no need to derive the expressions)

- 1.4 i) Define ripple factor and efficiency for the above circuits
ii) Write the expressions for ripple factor and efficiency
- 1.5 Compare HW, FW Centre tapped and Bridge Rectifiers
- 1.6 List the different types of filters used in rectifier circuits
- 1.7 Explain the working of a RC, CRC and CLC filter for a full wave rectifier
- 1.8 Define Voltage Regulation
- 1.9 State the need for a DC regulated power supply
- 1.10 Draw the block diagram of DC regulated power supply and explain the function of each block
- 1.11 Explain the working of a simple Zener regulator
- 1.12 List the types of IC regulators and give the advantages of IC regulators
- 1.13 Explain the operation of fixed positive and negative voltage Regulators (using 78xx and 79xx series)
- 1.14 Explain the operation of adjustable voltage regulator (LM317).

2.0 Transistor biasing and stabilization

- 2.1 i) Explain the concept of DC and AC load lines
ii) Define operating point of transistor amplifier
iii) List the factors affecting the operating point
iv) Analyze the selection of proper operating point
- 2.2 Explain the importance of transistor biasing
- 2.3 Explain the need for stabilization
- 2.4 Define stability factors and give their equations
- 2.5 List the types of biasing circuits
- 2.6 Explain the fixed bias circuit and list its drawbacks.
- 2.7 i) Explain self bias circuit
ii) State the importance of emitter by-pass capacitor, C_e in self bias circuit
iii) Analyze the stability of self bias circuit
iv) List the advantages of self bias circuit
- 2.8 Explain the concept of thermal runaway
- 2.9 State the importance of heat sink

3.0 Small Signal Amplifiers

- 3.1 Define h-parameters of BJT
- 3.2 Draw the h-model of CB, CE and CC transistor configurations
- 3.3 Draw the practical single stage transistor CE amplifier and explain the function of each component.
- 3.4 Classify the amplifiers based on frequency of operation, period of conduction and type of coupling.
- 3.5 State the need for Multistage amplifier (Cascading of amplifiers)
- 3.6 Define the terms gain, gain in db, frequency response and bandwidth of an amplifier
- 3.7 Explain the working of two-stage RC coupled amplifier with circuit diagram
- 3.8 Draw and explain the frequency response of RC coupled amplifier
- 3.9 Explain the working of two-stage transformer coupled amplifier with circuit diagram
- 3.10 Draw and explain the frequency response of transformer-coupled amplifier
- 3.11 Explain the working of direct coupled amplifier with circuit diagram

- 3.12 Explain the operation of Darlington pair with the help of circuit diagram
- 3.13 List three applications of Darlington pair.

4.0 Large signal Amplifiers

- 4.1 State the need for power amplifier
- 4.2 Compare voltage and power amplifier
- 4.3 Classify power amplifiers based on period of conduction
- 4.4 Explain the working of Class A, Class B, Class AB and Class C amplifiers with waveforms
- 4.5 Explain the working of Class-B Push-pull amplifier with circuit diagram
- 4.6 Explain the working of complementary symmetry Push-pull power amplifier with circuit diagram
- 4.7 List different distortions in power amplifiers
- 4.8 Explain the working of Class-AB Push-pull amplifier circuit
- 4.9 Mention the applications of Class C Amplifiers
- 4.10 Compare efficiency of different types of power amplifiers
- 4.11 Draw the circuit diagrams of single and double tuned amplifiers and give their frequency response curves.

5.0 Feedback Amplifiers and Oscillators

- 5.1 State the concept of feedback
- 5.2 Compare positive and negative feedback.
- 5.3 Explain negative feedback amplifier with block diagram
- 5.4 Derive the expression for the gain of negative feedback amplifier
- 5.5 List the four types of negative feedback amplifiers
- 5.6 Explain the effect of negative feedback on gain, bandwidth, input and output impedances of an amplifier
- 5.7 List the merits of negative feedback amplifiers
- 5.8 Draw the block diagrams of voltage series, current series, current shunt and voltage Shunt feedback amplifiers
- 5.9 Compare characteristics of the above feedback amplifiers
- 5.10 State the conditions (Barkhausen criteria) for an amplifier to work as an oscillator
- 5.11 Classify oscillator circuits
- 5.12 Explain the working of an RC phase shift oscillator with a circuit diagram
- 5.13 Explain the working of an Wein Bridge oscillator with a circuit diagram
- 5.14 Explain the working of Hartley oscillator with a circuit diagram
- 5.15 Explain the working of Colpitts oscillator with a circuit diagram
- 5.16 Write the expressions for frequency of oscillations and conditions for sustained oscillations of the above circuits
- 5.17 Draw the equivalent circuit of piezoelectric crystal
- 5.18 Explain the working of transistor crystal oscillator with a circuit diagram
- 5.19 List the advantages of crystal oscillators over other types of oscillators.
- 5.20 List the applications of RC,LC and Crystal oscillators.

COURSE CONTENT:

1.0 DC Power Supplies: Necessity of DC power supply- Half wave, Full wave and Bridge rectifiers Working , Wave forms, RMS value, Average value of voltages and currents - Ripple factor and efficiency – Comparison of HW, FW Centre tapped, and bridge rectifiers – Need for filters – Working of RC,CRC,CLC –Swinging choke – Need for regulated power supply – Voltage regulation – Zener regulator –IC regulator

2.0 Transistor biasing and Stabilization

DC and AC load lines, transistor biasing, operating point, types of biasing circuits, Fixed bias network,thermal runaway, bias stabilization, self bias network, heat sink

3.0 Small signal Amplifiers

h-parameters of a transistor amplifier-Practical transistor CE amplifier -Classification of amplifiers based on frequency, period of conduction and coupling- Multistage amplifier - gain, frequency response and bandwidth of an amplifier- RC coupled amplifier - frequency response of RC coupled amplifier- transformer coupled amplifier - Frequency response of transformer coupled amplifier- direct coupled amplifier - Darlington pair - applications of Darlington pair

4.0 Large signal Amplifiers

Need for Power Amplifier- comparison of voltage and power amplifier -Classification of power amplifiers based on conduction (Class A, B, AB, C)- operation of Class A, Class B, Class AB & Class C with waveforms- Working of Class B Push-pull amplifier circuit- Distortions in power amplifiers- Applications of Class C Amplifiers as - Efficiencies of different power amplifiers- Single tuned and Double tuned amplifier.

5.0 Feedback Amplifiers& Oscillators

Concept of feedback – positive and negative feed back-Block diagram of negative feedback amplifier - four types of negative feedback amplifiers- Block diagrams of voltage series, current series, current shunt and voltage Shunt feedback amplifiers- Expression for the gain of negative feedback amplifiers- Effect of negative feedback on gain, bandwidth, input and output impedances- comparison of characteristics of feedback amplifiers.

Oscillators

Condition for an amplifier to work as an oscillator (Barkhausen criteria) - RC phase shift oscillator – Wein bridge oscillator- Hartley oscillator- Colpitts oscillator - Equivalent circuit of crystal - crystal oscillator - Advantages of crystal oscillator- Applications of RC,LC and crystal oscillators.

REFERENCE BOOKS:

1. G.K.Mithal, Electronic Devices and Circuits, 23rd Edition, 2014, Khanna Publishers
2. David A.Bell, Electronic Devices and Circuits, 4th edition PHI, India Publishers
3. T.F. Bogart Jr, J.S.Beasley and G.Rico, Electronic Devices and Circuits, 6th edition, 2004 Pearson Education
4. Albert Malvino and J Bates, Electronic Principles, 7th edition Tata McGraw-Hill Education (TMH) Publishers.

5. V.K. Mehta, Principles of Electronics, 2008, S Chand & Company
 6. S.Salivahanan,N.Suresh kumar,Electronic devices & circuits , 4th edition,McGraw-Hill Education
 7. Allen Mottershead, Electronic devices & circuits,An introduction, PHI Publication

BLUE PRINT

SI No	Unit Title	No of Periods	Weightage Allotted	Weightage of Marks		COs mapped
				No of Essay Questions	No of Short answer Questions	
1	DC Power Supplies	12	21	1 ^{1/2}	2	CO1
2	Transistor Biasing and stabilization	8	18	1 ^{1/2}	1	CO2
3	Small Signal Amplifiers	10	19	1	3	CO3
4	Large Signal Amplifiers	10	23	2	1	CO4
5	Feedback amplifiers & Oscillators	20	29	2	3	CO5
		60	110	80	30	

Table specifying the scope of syllabus to be covered for Unit Tests

Unit Test	Learning outcomes to be covered
Unit Test-I	From 1.1 to 3.13
Unit Test-II	From 4.1 to 5.20

(Model Paper) C –23, EC -302
 State Board of Technical Education and Training, A. P
 Diploma in Electronics and Communication Engineering (DECE)
 III Semester
 Subject Name: Electronic Circuits-I
 Sub Code: EC - 302

Time : 90 minutes

Unit Test I

Max.Marks:40

Part-A

16Marks

Instructions: (1) Answer **all** questions.

(2) First question carries **four** marks, each question of remaining carries **three** marks

1. Fill the following blanks with one word
 - a) Bridge rectifier is a Half wave rectifier (TRUE/FALSE) (CO1)
 - b) Ripple factor of half wave rectifier is ----- (CO1)
 - c) What is heat sink (CO2)
 - d) Define h_{11} (CO3)
2. Compare HWR and FWR (CO1)
3. Define voltage regulation (CO1)
4. List the types of biasing circuits. (CO2)
5. Define the terms gain and bandwidth of an amplifier (CO3)

Part-B

3×8=24

Instructions: (1) Answer **all** questions.

(2) Each question carries **eight** marks

(3) Answer should be comprehensive and the criterion for valuation is the content but not the length of the answer.

6. (a) Explain the working of full wave bridge rectifier with wave forms (CO1)
(or)
(b) Explain the operation of adjustable voltage regulator (CO1)
7. (a) Explain fixed bias circuit (CO2)
(or)
(b) Explain Self Bias circuit and analyze the stability of self bias (CO2)
8. (a) Explain the working of two-stage transformer coupled amplifier with circuit diagram and explain its frequency response characteristics (CO3)
(or)
(b) Explain the operation of Darlington pair with the help of circuit diagram (CO3)

(Model Paper)

C –23, EC -302

State Board of Technical Education and Training, A. P
Diploma in Electronics and Communication Engineering (DECE)

III Semester

Subject Name: Electronic Circuits-I

Sub Code: EC-302

Part-A

16Marks

Instructions: (1) Answer **all** questions.
 (2) First question carries **four** marks, each question of remaining carries **three** marks

1. Fill the following blanks with one word
 - a) What is the efficiency of Class B amplifier (CO4)
 - b) Negative feedback is used in oscillators **(State True/False)** (CO5)
 - c) How many degrees phase shift is produced by feed back network of RC phase shift oscillator (CO5)
 - d) With the introduction of negative feedback the gain of an amplifier is decreases **(State True/False)** (CO5)
2. Compare Voltage and Power amplifier (CO4)
3. List any three applications of Class C Amplifiers (CO4)
4. State the concept of feedback in amplifiers (CO5)
5. State the conditions (Barkhausen's criteria) for an amplifier to work as an oscillator(CO5)

Part-B

3×8=24

Instructions: (1) Answer **all** questions.(2) Each question carries **eight** marks
 (3) Answer should be comprehensive and the criterion for valuation is the content but not the length of the answer.

6. (a) Explain the working of Class-B Push-pull amplifier with circuit diagram and waveforms (CO4)
 (or)
 (b) Explain the working of complementary symmetry Push-pull power amplifier with circuit diagram (CO4)
7. (a) Explain negative feedback amplifier with block diagram and Derive the expression for the gain of negative feedback amplifier (CO5)
 (or)
 (b) Explain the effect of negative feedback on gain, bandwidth, input and output impedances of an amplifier (CO5)
8. (a) Explain the working of an Wein bridge oscillator with a circuit diagram and Write the expressions for frequency of oscillations and mention the conditions required for sustained oscillations (CO5)
 (or)
 (b) Explain the working of Colpitts oscillator with a circuit diagram and Write the expressions for frequency of oscillations and mention the conditions required for sustained oscillations (CO5)

-o0o-

MODEL PAPER

BOARD DIPLOMA EXAMINATIONS

C-23, EC-302, ELECTRONIC CIRCUITS –I

III SEMESTER

SEMESTER END EXAMINATION

TIME:3 HOURS

MAX MARKS:80

Part-A

10×3=30

Instructions: (1) Answer **all** questions.
(2) Each question carries **three** marks
(3) Answer should be brief and straight to the point and shall not exceed five simple sentences.

1. Compare Half wave, Full wave Centre tapped, Bridge rectifiers in any 3 aspects(CO1)
2. Define ripple factor and efficiency of a rectifier. (CO1)
3. List the factors affecting the operating point (CO2)
4. Define h-parameters of BJT (CO3)
5. State the need for Multistage amplifier (CO3)
6. List the applications of Darlington pair (CO3)
7. State the need for Power Amplifier (CO4)
8. Compare positive and negative feedback (CO5)
9. Advantages of crystal oscillator over other oscillators (CO5)
10. State the conditions (Barkhausen's criteria) for an amplifier to work as an oscillator (CO5)

Part-B

5×10=50

Instructions: (1) Answer **any five** questions.
(2) Each question carries **10** marks
(3) Answer should be comprehensive and the criterion for valuation is the content but not the length of the answer.

11. Explain the working of centre tapped full wave rectifier with wave forms (CO1)
12. (a) Explain the working of Zener regulator (CO1)- 5M
(b) Explain the concept of DC and AC load lines (CO2) -5M
- 13 Explain fixed bias circuit and list its draw backs (CO2)
- 14 Explain the working of two-stage RC coupled amplifier with circuit diagram and explain its frequency response characteristics (CO3)
15. Explain the working of Class-B Push-pull amplifier with circuit diagram and waveforms (CO4)
16. Explain the working of double tuned amplifier with circuit diagram (CO4)
17. Explain the working of an RC phase shift oscillator with a circuit diagram and Write the expressions for frequency of oscillations and mention the conditions required for sustained oscillations (CO5)

18 Explain the working of crystal oscillator with a circuit diagram and list its advantages
(CO5)

-o0o-

DIGITAL ELECTRONICS

Course Code	Course title	No of periods/week	Total no of periods	Marks for FA	Marks for SA
EC-303	DIGITAL ELECTRONICS	4	60	20	80

S No	Unit Title	No. of Periods	COs Mapped
1	Basics of Digital Electronics.	15	CO1
2	Logic Families	7	CO2
3	Combinational Logic circuits.	15	CO3
4	Sequential Logic Circuits.	15	CO4
5	Semiconductor memories.	8	CO5
	TOTAL	60	

Course Objectives	1. To familiarize with various number systems, postulates of boolean algebra, logic gates and logic circuits
	2. To analyze the working of logic gates, combinational and sequential circuits and memories
	3. To learn the practical importance and applications of digital electronic circuits

CO No		COURSE OUTCOMES
CO1	EC-303.1	Convert a number from one system to another system, implement logic circuits and analyse logic expressions.
CO2	EC-303.2	Describe different logic families
CO3	EC-303.3	Design combinational logic circuits
CO4	EC-303.4	Construct different sequential logic circuits
CO5	EC-303.5	Describe different semiconductor memories

CO-PO/PSO MATRIX

CO No	PO1	PO2	PO3	PO4	PO5	PO6	PO7	PSO1	PSO2	PSO3
EC-303.1	3	3	1	1	1			3	1	
EC-303.2	3	3			1		1	3		
EC-303.3	3	3	3	1	1			3	1	1
EC-303.4	3	3	3	1	1			3	1	1
EC-303.5	3	3			1		1	3	1	1
Average	3	3	2.3	1	1		1	3	1	1

3=strongly mapped
2=moderately mapped

1=slightly mapped

LEARNING OUTCOMES:

1.0 Basics of Digital Electronics

- 1.1
 - i) Explain Binary, Octal, Hexadecimal number systems.
 - ii) Convert a given decimal number into Binary, Octal, and Hexadecimal number and vice versa
 - iii) Convert a given binary number into octal and hexadecimal number and vice versa
- 1.2 Perform binary addition, subtraction, multiplication and division.
- 1.3
 - i) Write 1's complement and 2's complement numbers for a given binary number.
 - ii) Perform subtraction of binary numbers in 2's complement method.
- 1.4 Compare weighted and Un-weighted codes.
- 1.5 Write Binary equivalent number for a number in 8421, Excess-3 and Gray Code and vice-versa.
- 1.6 Mention the use of alphanumeric codes (ASCII & EBCDIC)
- 1.7 State different postulates in Boolean algebra
- 1.8 Explain the basic logic gates AND, OR, NOT gates with their truth tables
- 1.9 Explain the working of universal logic gates (NAND, NOR gates) with truth tables
- 1.10 Explain the working of an Exclusive-OR gate with truth table
- 1.11
 - i) State De-Morgan's theorems
 - ii) Apply De-Morgan's theorems and other postulates to simplify Boolean expressions (up to three variables only)
- 1.12 Realize AND, OR, NOT operations using NAND, NOR gates
- 1.13 Explain standard representations for logical functions (SOP and POS form)
- 1.14 Write Boolean expressions from the given truth table
- 1.15 Write Boolean expressions for real life examples
- 1.16 Simplify Boolean Expression using Karnaugh map (up to 3 variables only)

2.0 Logic families

- 2.1 Classify logic families
- 2.2 List the important characteristics of Digital ICs of different logic families.
- 2.3 Define the terms: propagation delay, Noise margin, Fan-in, Fan-out and Power dissipation of digital ICs.
- 2.4 State the voltage and current logic levels of TTL and CMOS ICs.
- 2.5 Explain the working of Totem-pole output TTL NAND gate with circuit diagram.
- 2.6 Explain the working of open collector TTL NAND gate with circuit diagram.
- 2.7 Explain the working principle of CMOS Technology with diagram
- 2.8 Explain the working of CMOS NAND and CMOS NOR Gates with circuit diagram.
- 2.9 Compare the TTL, CMOS and ECL logic families.
- 2.10 List IC numbers of two input TTL Logic gates.

3.0 Combinational logic circuits

- 3.1 State the concept of combinational logic circuit.
- 3.2
 - i) Explain Half adder circuit using Ex-OR, AND gates
 - ii) Realize Half-adder using i) NAND gates only and ii) NOR gates only.
- 3.3
 - i) Explain the operation of Full adder circuit with truth table using Ex-OR gate and basic gates.

- ii) Realize full-adder using two Half-adders and an OR gate
- 3.4 Explain the working of 4 Bit parallel adder using full adders.
- 3.5 Explain the logic circuit of 4-bit 2's complement adder/subtractor.
- 3.6 Explain the working of 4-bit serial adder with block diagram.
- 3.7 Compare the performance of serial and parallel adders
- 3.8 Explain 4x1 Multiplexer with logic circuit
- 3.9 Mention any 3 applications of multiplexers
- 3.10 Explain 1x4 De-multiplexer with logic circuit
- 3.11 Mention any 3 applications of De-multiplexers.
- 3.12 Explain the working of 8x3 encoder
- 3.13 Explain the working of 3x8 decoder
- 3.14 Mention any 3 applications of decoders.
- 3.15 Explain the working of BCD to decimal decoder
- 3.16 State the need for a tri-state buffer.
- 3.17 Draw the logic symbols of unidirectional/ bi-directional tri-state buffers.
- 3.18 Draw and explain a simple tri-state buffer circuit.
- 3.19 Realize two bit digital comparator circuit using gates

4.0 Sequential logic circuits

- 4.1 State the concept of Sequential logic circuits.
- 4.2 Distinguish between combinational and sequential logic circuits
- 4.3 Explain NAND and NOR latches with truth tables.
- 4.4 i) State the necessity of clock in digital circuits
ii) Differentiate between level triggering and edge triggering
- 4.5 Explain clocked SR flip flop using NAND gates.
- 4.6 State the need for preset and clear inputs.
- 4.7 i) Explain level clocked JK flip flop (using S-R flip-flops) with truth table.
ii) State race around condition in JK flipflops
- 4.8 Explain the logic circuits of D-Flipflop and T-Flipflops with truth tables
- 4.9 Explain the master slave JK flip flop with necessary diagrams.
- 4.10 i) Give the concept of edge triggering.
ii) Draw the symbols of edge triggered D and T flip flops.
- 4.11 List the applications of flip flops.
- 4.12 Define the term modulus of a counter.
- 4.13 i) Explain the working of 4-bit asynchronous counter with circuit diagram and timing diagram.
ii) Explain the working of asynchronous decade counter with circuit diagram and Timing diagram.
iii) Explain the working of asynchronous 3 bit up-down counter with circuit diagram.
- 4.14 Explain the working of 4-bit synchronous counter with circuit diagram.
- 4.15 Distinguish between synchronous and asynchronous counters.
- 4.16 i) State the necessity of Registers and classify registers based on data i/o operations
ii) Explain the working of 4-bit shift left register with Circuit diagram
iii) Explain the working of 4-bit shift right register with Circuit diagram.
iv) List any four common applications of shift registers.

5.0 Semiconductor memories

- 5.1 Classify different types of semiconductor memories

- 5.2 Define the terms: i) memory read operation; ii) memory write operation; iii) access time; iv) memory capacity; v) address lines; vi) word length related to memories
- 5.3 Differentiate:
 - i) Read Only Memory & Read write memory ;
 - ii) Sequential access memory & Random Access Memory
- 5.4 Explain working of diode ROM with suitable circuit diagram
- 5.5 Distinguish between EEPROM and UVEPROM
- 5.6 Explain the working of basic dynamic MOS RAM cell with suitable circuit diagram
- 5.7 Compare static RAM and dynamic RAM
- 5.8 State the difference between Flash ROM and NV RAM
- 5.9 State the use of pen drive, SD Card, solid state hard disk.

COURSE CONTENT

1.0 Basics of Digital Electronics

Number systems- Conversion from one number system to another number system-Binary Arithmetic-Weighted and un-weighted codes - parity Bit- Boolean algebra – Basic gates- Universal gates - De-Morgan's theorems-Realize AND, OR, NOT operations using NAND, NOR gates-SOP and POS forms-Write Boolean expressions from the given truth table-Karnaugh map (up to 3 variables only)

2.0 Logic families.

Classify different logic families- characteristics of logic families-open collector TTL NAND gate with circuit diagram-Totem pole output TTL NAND gate –CMOS working Principle- Logic gates using CMOS Technology -Compare TTL, CMOS and ECL

3.0 Combinational logic circuits

Concept of combinational logic circuits- Half adder circuit - Full adder circuit - a 4 Bit parallel adder using full adders- 2's compliment parallel adder/ Subtractor circuit- Serial adder - Performance of serial and parallel adder- Operation of 4x1 Multiplexers- Operation of 1 to 4 de-multiplexer- applications- 8x3 Encoder - 3x8 decoder- Applications - Tri-state buffer-working of simple tri state buffer -Types of tri-state buffers- one bit digital comparator.

4.0 Sequential logic circuits

Concept of Sequential logic circuits- NAND and NOR latches - Necessity of clock - Concept of level and edge triggering - Clocked SR flip flop circuit using NAND gates- Need for preset and clear inputs - Circuit of level Clocked JK flip flop (using S-R flip-flops) -Race around condition-Master slave JK flip flop circuit - edge triggered clocked D and T flip flops - Truth table, Circuit diagram - Symbols of above Flip Flops- - Applications of flip flops-Modulus of a counter- 4-bit asynchronous counter - Asynchronous decade counter with a circuit - 4-bit synchronous counter –differences between synchronous and asynchronous counters- asynchronous 3 bit up-down counter – Need for a Register - Types of registers- 4 bit shift left and shift right registers - Applications of shift registers.

5.0 Semiconductor memories

Types of memories -Memory read operation, write operation, access time, memory capacity, address lines and word length- ROM and RAM- Diode ROM- EEPROM and UVEPROM- Dynamic

MOS RAM cell- static RAM and dynamic RAM- Differences between Flash ROM and NV RAM – use of pen drive, SD card, solid state disk

REFERENCE BOOKS:

1. 1. Malvino and Leach, Digital Computer Electronics, 3rd edition Tata McGraw-Hill Edition
2. RP JAIN , Modern Digital Electronics, 3th edition TMH
3. Roger L. Tokheim , Digital Electronics: Principles & Application, McGraw-Hill Edition, 2008
4. GK Kharate , Digital Electronics, Oxford University Press.
5. V.K.Puri, Digital Electronics, Tata McGraw-Hill.
6. M.Morris Mano, Digital logic & Computer Design, PEARSON Edition 2017
7. M.Morris Mano, Michael D. Ciletti, Digital Design , PEARSON 4th Edition

BLUE PRINT

SI No	Unit Title	No of Periods	Weightage Allotted	Weightage of Marks		COs mapped
				No of Essay Questions	No of Short answer Questions	
1	Basics of Digital Electronics.	15	26	2	2	CO1
2	Logic Families	7	26	1	2	CO2
3	Combinational Logic circuits.	15	16	1	2	CO3
4	Sequential Logic Circuits.	15	16	2	2	CO4
5	Semiconductor memories.	8	26	2	2	CO5
		60	110	80	30	

Table specifying the scope of syllabus to be covered for Unit Tests

Unit Test	Learning outcomes to be covered
Unit Test-I	From 1.1 to 3.7
Unit Test-II	From 3.8 to 5.9

(Model Paper) C –20, EC -303
State Board of Technical Education and Training, A. P

Diploma in Electronics and Communication Engineering (DECE)

III Semester

Subject Name: Digital Electronics

Sub Code: EC - 303

Time : 90 minutes

Unit Test-I

Max.Marks:40

Part-A

16Marks

Instructions: (1) Answer **all** questions.
(2) First question carries **four** marks, each question of remaining carries **three** marks

1. Convert the following numbers into binary number system (CO1)
a) 25_{10} b) 72_8 c) AB_{16} d) $2A_{16}$
2. Perform the binary subtraction of following two numbers using 2's complement method (CO1)
 101101_2
 -100110_2

3. State De-Morgan's theorems (CO1)
4. Classify different logic families (CO2)
5. Define the terms: propagation delay, Noise margin, Fan out of digital ICs (CO2)

Part-B

3×8=24

Instructions: (1) Answer **all** questions.
(2) Each question carries **eight** marks
(3) Answer should be comprehensive and the criterion for valuation is the content but not the length of the answer.

6. (a) Realize AND, OR, NOT operations using NAND, NOR gates (CO1)
(or)
(b) Simplify the following Boolean Expression using Karnaugh map (CO1)
$$Y = \overline{A}BC + A\overline{B}C + \overline{A}B\overline{C} + ABC$$
7. (a) Explain the working of open collector TTL NAND gate with circuit diagram. (CO2)
(or)
(b) Explain the working of Totem-pole output TTL NAND gate with circuit diagram. (CO2)
8. (a) Explain 4-bit parallel adder cum 2's complement subtractor circuit. (CO3)
(or)
(b) Explain the operation of Full adder circuit with truth table using Ex-OR gate and basic gates. (CO3)

-oOo-

MODEL PAPER

Diploma in Electronics and Communication Engineering (DECE)

III Semester

Subject Name: Digital Electronics

Sub Code: EC - 303

Time : 90 minutes

Unit Test II

Max.Marks:40

Part-A

16Marks

Instructions: (1) Answer **all** questions.
(2) First question carries **four**marks, each question of remaining carries **three** marks

1. a) Write one example for combinational logic circuit? (CO3)
b) Write one example for sequential logic circuit? (CO4)
c) Write full form of EEPROM (CO5)
d) Write full form of NV RAM (CO5)
2. Compare the performance of serial and parallel adder (CO3)
3. State the need for preset and clear inputs. (CO4)
4. List the applications of flip flops (CO4)
5. Classify different types of semiconductor memories (CO5)

Part-B

3×8=24

Instructions: (1) Answer **all** questions.
(2) Each question carries **eight** marks
(3) Answer should be comprehensive and the criterion for valuation is the content but not the length of the answer.

6. (a) Explain the working of 4-bit asynchronous counter with circuit diagram and timing diagram. (CO3)
(or)
(b) Explain the working of asynchronous decade counter with circuit diagram and timing diagram. (CO3)
7. (a) Explain the working of 4-bit shift left register with Circuit diagram (CO4)
(or)
(b) Explain the working of 4-bit shift right register with Circuit diagram. (CO4)
8. (a) Explain working of diode ROM with suitable circuit diagram (CO5)
(or)
(b) Explain the working of basic dynamic MOS RAM cell with suitable circuit diagram (CO5)

-oOo-

MODEL PAPER

BOARD DIPLOMA EXAMINATIONS
C-23, EC-303, DIGITAL ELECTRONICS
III SEMESTER
SEMESTER END EXAMINATION

TIME:3 HOURS

MAX MARKS:80

Part-A

10×3=30

- Instructions:** (1) Answer **all** questions.
(2) Each question carries **three** marks
(3) Answer should be brief and straight to the point and shall not exceed five simple sentences.

1. Convert the following numbers into binary number system (CO1)

a) 25_{10} b) 72_8 c) AB_{16}

2. Perform the following binary subtraction using 2's complement method (CO1)
(CO1)

101101_2

-100110_2

3. Classify different logic families (CO2)
4. List types of tri-state buffers. (CO2)
5. Draw Half adder circuit and give its truth table (CO3)
6. Compare the performance of serial and parallel adder (CO3)
7. State the need for preset and clear inputs. (CO4)
8. List the applications of flip flops (CO4)
9. Classify different types of semiconductor memories (CO5)
10. State the difference between Flash ROM and NV RAM (CO5)

Part-B

5×10=50

- Instructions:** (1) Answer **any 5** questions.
(2) Each question carries **ten** marks
(3) Answer should be comprehensive and the criterion for valuation is the content but not the length of the answer.

11. Realize AND, OR, NOT operations using NAND, NOR gates (CO1)

12. Simplify the following Boolean Expression using Karnaugh map (CO1)

$$Y = \overline{A}BC + A\overline{B}C + \overline{A}B\overline{C} + ABC$$

13. Explain the working of Totem-pole output TTL NAND gate with circuit diagram. (CO2)
14. Explain 4x1 Multiplexer with logic circuit diagram (CO3)
15. Realize one bit digital comparator circuit using gates (CO3)
16. Explain the working of master slave JK flip flop (CO4)
17. Explain the working of 4-bit asynchronous counter with circuit diagram and draw the timing diagram. (CO4)
18. Explain working of diode ROM with suitable circuit diagram (CO5)

-oOo-

Course Code	Course title	No of periods/week	Total no of periods	Marks for FA	Marks for SA
EC-304	Analog and Digital Communication systems	5	75	20	80

S No	Unit Title	No. of Periods	COs Mapped
1	Amplitude Modulation	10	CO1
2	Angle Modulation techniques	8	CO2
3	Transmitters and Receivers	15	CO3
4	Digital communication principles	12	CO4
5	Digital modulation techniques	15	CO5
	TOTAL	60	

Course Objectives	1. To familiarize the concepts of analog communication systems and digital communication systems
	2. To equip with various issues related to analog and digital communications such as modulation, demodulation, transmitters, receivers and noise performance
	3. To learn the practical importance and applications of communication systems

CO No	COURSE OUTCOMES	
CO1	EC-304.1	Understand the amplitude modulation techniques.
CO2	EC-304.2	Familiarize with angle modulation methods.
CO3	EC-304.3	Describe the principles and working of transmitters and receivers.
CO4	EC-304.4	Interpret the Digital Communication and multiplexing techniques.
CO5	EC-304.5	Describe different digital modulation techniques and Modems.

CO-PO/PSO MATRIX

CO No	PO1	PO2	PO3	PO4	PO5	PO6	PO7	PSO1	PSO2	PSO3
EC-404.1	3	2			2		2	3		2
EC-404.2	3	2			2		2	3		2
EC-404.3	3	1	1		2		2	3	1	2
EC-404.4	3	1	1		2		3	3	2	2
EC-404.5	3	3	3		2		3	3	2	2
Average	3	1.8	1	0	2	0	2.4	3	1	2

3=strongly mapped

2=moderately mapped

1=slightly mapped

LEARNING OUTCOMES:

1.0 Amplitude modulation techniques

- 1.1 Explain the basic elements of a communication system with a block diagram
- 1.2 Explain the frequency spectrum of radio waves and state the applications of each band
- 1.3 Explain about time domain and frequency domain waveforms.
- 1.4 Define modulation and state the need for modulation in communication systems.
- 1.5 Define baseband signal, carrier signal and modulated signal.
- 1.6 Classify various types of continuous wave modulation systems
- 1.7 Define amplitude modulation and draw its waveform
- 1.8 Define the modulation index of an AM signal.
- 1.9 Derive the time-domain equation for an AM signal.
- 1.10 Explain the frequency spectrum of an AM wave and hence calculate its Bandwidth
- 1.11 State the effects of over modulation
- 1.12 Derive the relation between total power and carrier power in AM and Solve simple problems
- 1.13 State the need for DSB-SC and SSB modulation and list their advantages and disadvantages of SSB.

2.0 Angle Modulation

- 2.1 Define angle modulation
- 2.2 List the types of angle modulation
- 2.3 Define Frequency modulation and draw its waveform.
- 2.4 Define the modulation index of an FM signal
- 2.5 Define Phase Modulation
- 2.6 Derive the time domain equation for FM signal and explain its bandwidth requirements.
- 2.7 Explain the frequency spectrum of FM wave
- 2.8 Distinguish between narrow band and wide band FM
- 2.9 Higher frequency components of FM signal are affected most by noise: Justify with Noise triangle.
- 2.10 Define the terms pre-emphasis and de-emphasis
- 2.11 Distinguish between FM and PM
- 2.12 List the merits of FM over AM

- 2.13 Classify different types of noise
- 2.14 Define the terms: i) Signal to Noise Ratio; ii) Noise Figure; and iii) Noise Temperature

3.0 Transmitters and Receivers

- 3.1 List the specifications of transmitters.
- 3.2 Distinguish between low level and high-level modulation
- 3.3 Draw the block diagram for high level modulated transmitter and explain its working
- 3.4 Draw the low-level modulated Transmitter and explain its working
- 3.5 Draw the block diagram of FM transmitter using reactance method and explain its working
- 3.6 Draw and explain the block diagram of indirect method of FM generation (Armstrong method)
- 3.7 Classify radio receivers
- 3.8 Define sensitivity, selectivity and fidelity of a radio receiver
- 3.9 i) Draw the block diagram of TRF receiver and explain the function of each block.
ii) State the limitations of TRF Receiver
- 3.10 Explain the working of super heterodyne AM receiver with a block diagram.
- 3.11 Define the terms Image frequency and IMRR in a radio receiver.
- 3.12 State the factors to be considered for choice of IF.
- 3.13 State the need for AVC (AGC).
- 3.14 Explain the process of demodulation with Envelope detector in AM receivers
- 3.15 Draw and explain the circuit diagram of practical AM detector
- 3.16 Explain the working of super heterodyne FM receiver with a block diagram.
- 3.17 Explain the process of demodulation with Foster-Seeley discriminator (Phase discriminator) in FM receivers

4.0 Digital Communication Principles

- 4.1 Distinguish between analog and digital signals
- 4.2 List the advantages and disadvantages of digital communication system over analog communication system
- 4.3 Define information capacity of a channel.
- 4.4 State sampling theorem and mention its significance in pulse modulation techniques
- 4.5 Classify pulse modulation techniques.
- 4.6 Define PAM and its waveform
- 4.7 Define PWM and its waveform
- 4.8 Define PPM and its waveform
- 4.9 Compare PAM, PWM and PPM
- 4.10 Define the term quantization
- 4.11 Explain the process of quantization with waveforms.
- 4.12 State quantization noise.
- 4.13 Describe the coding and decoding of a PCM signal.
- 4.14 Define Multiplexing in digital communications
- 4.15 State the need for multiplexing
- 4.16 Explain the concept of Frequency Division Multiplexing with block diagram
- 4.17 Explain the concept of Time Division Multiplexing with block diagram
- 4.18 Compare TDM and FDM

5.0 Digital Modulation Techniques

- 5.1 State data encoding
- 5.2 List different analog signal to digital signal encoding schemes
- 5.3 Explain the process of Asynchronous data communication scheme
- 5.4 Define Overhead and Efficiency of data communication system
- 5.5 Explain the process of synchronous data communication
 - i) List different error detection schemes
 - ii) Explain parity check method of error detection.
 - iii) Explain Checksum method of error detection.
 - iv) Explain CRC method of error detection with an example.
 - v) Explain method of error correction using FEC method (Hamming Code).
- 5.6 State the need for digital modulation
- 5.7 State the difference between bit rate and baud rate
- 5.8 Define ASK, FSK and PSK
- 5.9 Explain Binary ASK modulator with block diagram.
- 5.10 Explain Binary ASK coherent demodulator with block diagram
- 5.11 Explain BFSK modulator with block diagram.
- 5.12 Explain Coherent BFSK demodulator.
- 5.13 Explain BPSK modulator with block diagram
- 5.14 Explain BPSK demodulator with block diagram
- 5.15 Compare ASK, FSK and PSK
- 5.16 State the need for QAM
- 5.17 Explain 4QAM Modulator with block diagram
- 5.18 State the need for a MODEM in data communications
- 5.19 List different types of MODEMs
- 5.20 State the concept of Digital Subscriber Line (DSL) technology
- 5.21 List the features of Asynchronous Digital Subscriber Line (ADSL) technology

COURSE CONTENT:

1.0 Amplitude modulation techniques

Elements of a communication system - block diagram- frequency spectrum – time domain signal-frequency domain signal - need for modulation in communication systems- baseband, carrier, and modulated signals -amplitude modulation- wave form of an AM wave- time-domain equation for an AM signal- modulation index of an AM signal- frequency spectrum of an AM signal-bandwidth of an AM signal - effects of over modulation - relation between total power and carrier power in AM-Solve simple problems- need for DSBSC and SSB modulation- advantages and disadvantages of SSB

2.0 Angle Modulation

Angle modulation- types of angle modulation-Definition of Frequency modulation - Phase modulation - time domain equation for FM signal-bandwidth of FM signal modulation index of an FM signal- frequency spectrum of FM - narrow band and wide band FM- noise triangle in FM- pre-emphasis and de-emphasis - differences between FM and PM - Merits of FM over AM- types of noise- signal to noise ratio, noise figure and noise temperature.

3.0 Transmitters and Receivers.

Specifications of transmitters- Distinguish between low level and high level modulation -block diagram for high level modulated transmitter - block diagram for low level modulated Transmitter - block diagram of FM transmitter(reactance tube) - block diagram of indirect FM transmitter (Armstrong method)-classify radio receivers- sensitivity, selectivity and fidelity- block diagram of TRF receiver - limitations of TRF Receiver-super heterodyne receiver – Define the terms image frequency, IMRR- choice of IF- AVC –Envelop detector –FM receiver- Foster-Seeley discriminator.

4.0 Digital Communication Principles

Distinguish analog, digital signals -Analog, digital communication systems- Information capacity of channel-Sampling theorem - pulse modulation techniques – PAM – PWM – PPM - Quantization-Coding and decoding of PCM- Multiplexing techniques- need for Multiplexing – FDM- TDM- comparison of FDM and TDM

5.0 Digital Modulation Techniques

Data encoding- Analog, digital encoding schemes- Asynchronous data communication – Overhead, efficiency- synchronous data communication – Error detection – Parity check – Check sum- CRC – Error correction – Digital modulation – bit rate, baud rate - Define ASK, FSK –Binary ASK- BFSK- BPSK- QAM, Compare ASK, FSK, PSK, QAM-- modem – need of modem – types of modem -DSL- ADSL

REFERENCE BOOKS:

1. Roy Blake, Thomson Delmar Electronic communications systems
2. George Kennedy- Bernard Davis Electronic Communication System Tata Mcgraw Hill Education Private Limited
3. S.Salivahanam, A.Vallavaraj&C.Gnanapriya, Signal Systems and Communication
4. Herbert Taub& Donald L Schilling, Principles Of Electronic Communication Systems, 3rd Edition-2009.McGraw Hill Education (India) Private Limited
5. G.K.Mithal, Radio communication - khanna publishers
6. Wayne Thomassi, Electronic communication systems 4th edition Pearson publication
7. T.L.Singhal, Analog & Digital communication, McGraw Hill Education

BLUE PRINT

SI No	Unit Title	No of Periods	Weightage Allotted	Weightage of Marks		COs mapped
				No of Essay Questions	No of Short answer Questions	
1	Amplitude Modulation Techniques	10	21	1.5	2	CO1
2	Angle Modulation	8	16	1	2	CO2
3	Transmitters and Receivers	15	26	2	2	CO3
4	Digital communication principles	12	21	1.5	2	CO4
5	Digital	15	26	2	2	CO5

	modulation techniques					
		60	110	80	30	

Table specifying the scope of syllabus to be covered for Unit Tests

Unit Test	Learning outcomes to be covered
Unit Test-I	From 1.1 to 3.10
Unit Test-II	From 3.11 to 5.21

State Board of Technical Education and Training, A. P
Diploma in Electronics and Communication Engineering (DECE)

III Semester

Subject Name: **Analog and Digital Communication Systems**

Sub Code: **EC-304**

Time : 90 minutes

Unit Test I

Max.Marks:40

Part-A

16Marks

Instructions: (1) Answer **all** questions.

(2) First question carries **four** marks, each question of remaining carries **three** marks

1. Write the full form for the following abbreviations
 - a) DSB-SC (CO1)
 - b) VSB (CO1)
 - c) SSB (CO1)
 - d) IMRR (CO2)
2. State the need for modulation in communication systems (CO1)
3. List any three merits of FM over AM (CO1)
4. Classify different types of noise (CO1)
5. List the specifications of transmitters. (CO2)

Part-B

3×8=24

Instructions: (1) Answer **all** questions.

(2) Each question carries **eight** marks

(3) Answer should be comprehensive and the criterion for valuation is the content but not the length of the answer.

6. (a) Explain the basic elements of a communication system with a block diagram (CO1)
(or)
(b) Derive the time-domain equation for an AM signal and Define the modulation index of an AM signal. (CO1)
7. (a) Draw the block diagram for low level modulated transmitter and explain its working (CO2)
(or)
(b) Explain the process of demodulation with Foster-Seeley discriminator in FM receivers (CO2)
8. (a) Draw the block diagram for high level modulated transmitter and explain its working (CO1)
(or)
(b) Explain CRC method of error detection with an example. (CO2)

-oOo-

(Model Paper)

C –23, EC-304

State Board of Technical Education and Training, A. P
Diploma in Electronics and Communication Engineering (DECE)

III Semester

Subject Name: **Analog and Digital Communication Systems**

Sub Code: **EC - 304**

Time : 90 minutes

Unit Test II

Max.Marks:40

Part-A

16Marks

Instructions: (1) Answer **all** questions.
(2) First question carries **four** marks, each question of remaining carries **three** marks

1. Write the full form for the following abbreviations
 - a) PCM (CO3)
 - b) TDM (CO3)
 - c) QAM (CO4)
 - d) MODEM (CO4)
2. Define information capacity of a channel (CO3)
3. Compare the basic principle of ASK,FSK and PSK (CO4)
4. Define Overhead and Efficiency of data communication system (CO4)
5. State the need for a MODEM in data communications (CO4)

Part-B

3×8=24

Instructions: (1) Answer **all** questions.
(2) Each question carries **eight** marks
(3) Answer should be comprehensive and the criterion for valuation is the content but not the length of the answer.

- 6.(a) Explain PAM and Compare PAM, PWM and PPM (CO3)
(or)
(b) Describe the coding and decoding of a PCM signal
7. (a) Explain Binary ASK modulator with block diagram (CO4)
(or)
(b) Explain BPSK modulator with block diagram (CO3)
8. (a) Explain the concept of Frequency Division Multiplexing with a block diagram (CO4)
(or)
(b) Explain the concept of Time Division Multiplexing with a block diagram (CO4)

-o0o-

BOARD DIPLOMA EXAMINATIONS

C-23, EC-304, ANALOG AND DIGITAL COMMUNICATION SYSTEMS
III SEMESTER
MODEL PAPER - SEMESTER END EXAMINATION

TIME:3 HOURS

MAX MARKS:80

Part-A

10×3=30

Instructions: (1) Answer **all** questions.
(2) Each question carries **three** marks
(3) Answer should be brief and straight to the point and shall not exceed five simple sentences.

1. State the need for modulation in communication systems (CO1)
2. Determine the carrier power of AM transmitter radiating a power of 400kW, when modulated to a depth of 75% (CO1)
3. List any three merits of FM over AM (CO2)
4. Classify different types of noise (CO2)
5. List the specifications of transmitters (CO3)
6. Distinguish between analog and digital signals (CO3)
7. State the need for sampling while converting analog signal to into digital signal (CO4)
8. State thye need for multiplexing (CO4)
9. List different error detection methods (CO5)
10. State the need for a MODEM in data communications (CO5)

Part-B

5×10=50

- Instructions:** (1) Answer **any Five** questions.
(2) Each question carries **TEN** marks
(3) Answer should be comprehensive and the criterion for valuation is the content but not the length of the answer.

11. Derive the time-domain equation for an AM signal and draw its frequency spectrum (CO1)
12. Mathematically show that angle modulated signal requires infinite bandwidth (CO2)
13. Draw the block diagram for high level modulated transmitter and explain its working (CO3)
14. Explain the process of demodulation with Foster-Seeley discriminator in FM receivers (CO3)
15. Explain the block diagram Frequency division multiplexing (CO4)
16. Explain block diagram of ASK Modulator and Demodulator (CO5)
17. Explain the concept of ADSL Modem with a block diagram (CO5)
18. a) Explain the need for SSB (5Marks) (CO1)
b) Write the need for sampling and quantization (5Marks) (CO4)

NETWORK ANALYSIS

Course Code	Course title	No of periods/week	Total no of periods	Marks for FA	Marks for SA
EC- 305	Network Analysis	5	75	20	80

S No	Unit Title	No. of Periods	COs Mapped
1	Mesh current and Node voltage analysis	18	CO1
2	Network Theorems	20	CO2
3	Resonance	12	CO3
4	Transient analysis, Laplace transforms and its applications	18	CO4
5	Filters and Attenuators	7	CO5
TOTAL		75	

Course Objectives	1. To learn network analysis techniques, theorems, transients, filters and attenuators.
	2. To analyze networks using mesh, node analysis, transient analyses, filters, attenuators etc.
	3. To learn the practical importance Network analysis.

CO No		COURSE OUTCOMES
CO1	EC-305.1	Apply mesh and node analysis in solving circuits.
CO2	EC-305.2	Verify different network theorems.
CO3	EC-305.3	Construct resonance circuits and determine different parameters.
CO4	EC-305.4	Describe transient analysis, Laplace transforms and applications.
CO5	EC-305.5	Explain different filters and attenuators.

CO-PO/PSO MATRIX

CO No	PO1	PO2	PO3	PO4	PO5	PO6	PO7	PSO1	PSO2	PSO3
EC-305.1	3	3	1	2				3	1	1
EC-305.2	3	3	1	2				3	1	1
EC-305.3	3	3	1	2				3	1	1
EC-305.4	3	3	1	2				3	1	1
EC-305.5	3	3	3	2				3	1	1
Average	3	3	1.4	2				3	1	1

3=strongly mapped

2=moderately mapped

1=slightly mapped

LEARNING OUTCOMES:

1.0 Mesh current and Node voltage analysis

- 1.1 Define the terms: branch, node, junction and loop in circuits
- 1.2 Determine the number of mesh equations required to solve the given Network
- 1.3 Write the mesh current equations for a given network and arrange them in matrix form
- 1.4 Solve the mesh currents using Cramer's rule.
- 1.5 Determine the number of node voltage equations for a given network
- 1.6 Write the node voltage equations for a given network and arrange them in matrix form.
- 1.7 Solve the node voltages using Cramer's rule
- 1.8 Explain duality of a network
- 1.9 Draw the dual of given network.

2.0 Network theorems

- 2.1 State Thevenin's, and Norton's theorems and mention their use
- 2.2 Apply the above theorems to solve networks
- 2.3 State superposition theorem
- 2.4 Solve simple problems using superposition theorem
- 2.5 State Maximum power transfer theorem for DC & AC circuits.
- 2.6 Solve simple problems using maximum power transfer theorem
- 2.7 State the importance of impedance matching.
- 2.8 State Reciprocity theorem
- 2.9 State the importance of Reciprocity theorem.
- 2.10 List the advantages and limitations of above theorems
- 2.11 Explain star and Delta configurations of resistances
- 2.12 Give transformation formulas from Star to Delta & Delta to Star (no derivation)
- 2.13 Solve simple problems on Star/Delta and Delta/Star transformation

3.0 Resonance

- 3.1 Explain the concept of resonance in RLC series circuit
- 3.2
 - i) State the conditions for series resonance
 - ii) Derive the formula for frequency of resonance in series RLC circuit
 - iii) Draw the characteristic curves for series resonance
 - iv) Define bandwidth of a resonant circuit
 - v) Define lower cut off and upper cut off frequencies
 - vi) Give formula for lower cut off and upper cut off frequencies
 - vii) Solve simple problems on series Resonance.
- 3.3 Explain Parallel AC circuit containing RLC
- 3.4 List the 3 methods
 - a) Vector or phasor method
 - b) Admittance method
 - c) Vector algebra method for solving AC parallel circuits.
- 3.5 Solve problems using above 3 methods
- 3.6 Explain Resonance in parallel circuits
- 3.7 State the conditions required for parallel resonance

- 3.8 Derive Equation for resonant frequency in parallel resonant circuit
- 3.9 Give graphical representation of parallel resonance.
- 3.10 Compare Series and parallel resonance
- 3.11 Solve problems on Resonance
- 3.12 Explain the effect of resistance on Bandwidth.

4.0 Transient analysis, Laplace transform and its applications in circuit analysis

- 4.1 Define the terms: i) initial conditions; ii) steady state; and iii) transient state
- 4.2 i) Explain the dc response of RL circuit.
ii) Derive expression for current in RL circuit.
- 4.3 i) Explain the dc response of RC circuit.
ii) Derive expression for current in an RC circuit.
- 4.4 Explain the dc response of an RLC circuit.
- 4.5 Solve simple problems on series RL,RC circuits for DC excitation.
- 4.6 Define Laplace Transform and know the concept of complex frequency
- 4.7 State the use of Laplace transform to convert from time domain to frequency domain (S-domain)
- 4.8 Define i) delta function ii) unit step function iii) ramp function iv) exponential function
- 4.9 Write Laplace transforms of following functions: i) delta function ii) Unit step function iii) ramp function iv)exponential function v) sine and cosine functions vi) hyperbolic sine and cosine functions vii) damped sine function viii) damped hyperbolic cosine and sine functions
- 4.10 State inverse Laplace transform
- 4.11 Write inverse Laplace transforms corresponding to Laplace transform of the following functions: i) Unit step function ii) exponential function iii) sine and cosine functions iv) hyperbolic sine and cosine functions v) damped sine function vi) damped hyperbolic cosine and sine functions
- 4.12 Represent the element models of resistance, inductance and capacitances in time and S-domains
- 4.13 Apply Laplace transform to solve simple problems on RL, RC, RLC circuits.

5.0 Filters and attenuators

- 5.1 Define the terms: neper, decibel, characteristic impedance, propagation constant and Attenuation
- 5.2 Define the terms: filter, LPF, HPF, BPF and BSF
- 5.3 Draw the characteristic curves for the above filters
- 5.4 Give the expression for f_c for constant K-LPF,HPF
- 5.5 List the disadvantages of constant K filters.
- 5.6 State the function of attenuator circuit and list different types of attenuators.
- 5.7 Explain T & π type attenuators with circuit diagram

COURSE CONTENT

1.0 Mesh current and Node voltage analysis

Define: branch, node, junction, loop - Mesh current equations – Solve problems - Node voltage equations -simple problems - duality

2.0. Network theorems

The venin's, and Norton's theorems – solve problems - superposition theorem- Maximum power transfer theorems- solve problems – impedance matching - Reciprocity theorem -

advantages and limitations of above theorems - star and Delta transformation - delta to star transformation-simple problems

3.0. Resonance

Concept of resonance in RLC series circuit -Conditions for series resonance- frequency of resonance in series RLC circuit- Characteristic curves for series resonance- bandwidth of a resonant circuit- Lower cut off and upper cut off frequencies- Formula for lower cut off and upper cut off frequencies- Simple problems on series Resonance- Parallel AC circuit containing RLC- methods a) Vector or pharos method b) Admittance method c) Vector algebra method for solving AC parallel circuits-Simple problems using above 3 methods- Resonance in parallel circuits- Conditions required for parallel resonance- Equation for resonant frequency- Graphical representation of parallel resonance- Series and parallel resonance comparison-Problems on resonance- Effect of Resistance on Bandwidth

4.0 Transient analysis, Laplace transform and its applications in circuit analysis

Definition of initial condition,steady state,transient state-DC response for RL, RC,RLC circuits-Solve the simple problems on series RL,RC circuits of DC excitation- delta function, unit step function, ramp function, exponential function- lapalce transforms for the above functions-element models of R, L, C in time and frequency domains-simple network problems using Laplace transforms.

5.0 Filters and attenuators

Define neper, decibel, characteristic impedance, propagation constant, Attenuation-Define filter, LPF, HPF, BPF, BSF- characteristic curves of filters - constant K-LPF, HPF-disadvantages –Function of attenuator - T & π attenuators

REFERENCE BOOKS

1. Hayt&Kemerly, Engineering Circuit analysis, 8th edition, McGraw Hill Publishers
2. Van Valkenberg, Network analysis, PHI
3. Sudhakar&Shyam Mohan, Circuits and Networks,TMH
4. Joseph Adminster, Network Theory- Schaum Series, McGraw Hill Publishers
5. D Roy Choudhury, Networks and Systems, Wiely Eastern Limited
6. Dr.Shyalashree.N,Dr. Mamatha A.S,Dr.Abhaydeshpande,Dr.V.Sridhar,Network theory: a simplified approach, 3rd Edition, MEDTECH
7. A.Chakrabarti,Circuit Theory(Analysis & syntheses),Dhampat rai & co

BLUE PRINT

SI No	Unit Title	No of Periods	Weightage Allotted	Weightage of Marks		COs mapped
				No of Essay Questions	No of Short answer Questions	
1	Mesh current and Node voltage analysis	18	26	2	2	CO1
2	Network Theorems	20	26	2	2	CO2
3	Resonance	12	16	1	2	CO3
4	Transient analysis, Laplace transforms and	18	26	2	2	CO4

	its applications					
5	Filters and Attenuators	7	16	1	2	CO5
		75	110	80	30	

Table specifying the scope of syllabus to be covered for Unit Tests

Unit Test	Learning outcomes to be covered
Unit Test-I	From 1.1 to 2.13
Unit Test-II	From 3.1 to 5.7

(Model Paper) C –20, EC -305
 State Board of Technical Education and Training, A. P
 Diploma in Electronics and Communication Engineering (DECE)
 III Semester

Subject Name: Network Analysis

Sub Code: EC - 305

Time : 90 minutes

Unit Test I

Max.Marks:40

Part-A

16Marks

Instructions: (1) Answer **all** questions.
 (2) First question carries **four** marks, each question of remaining carries **three** marks

1. Fill the following blanks with one word
 - a) The connecting path between two nodes is called as _____ (CO1)
 - b) _____ is the point where two or more elements (RLC) connected together. (CO1)
 - c) The internal resistance of ideal voltage source _____ (CO2)
 - d) The internal resistance of ideal current source _____ (CO2)
2. Write the mesh current equations for the network shown below (CO1)

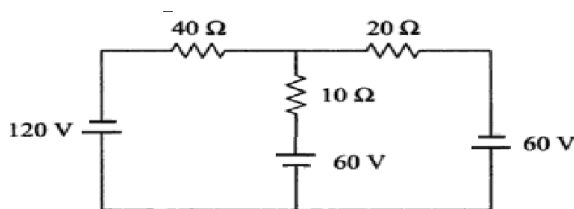

3. Find the V_1 node voltage by applying KCL (CO1)

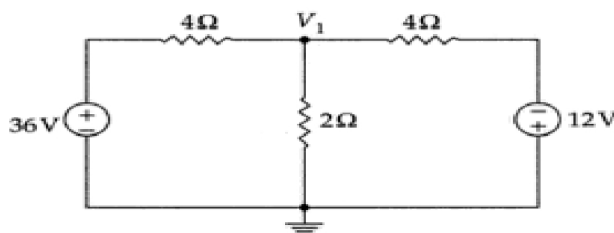

4. State Reciprocity theorem (CO2)
5. Give transformation formulas from Star to Delta (CO2)

Part-B

3×8=24

Instructions: (1) Answer **all** questions.
 (2) Each question carries **eight** marks
 (3) Answer should be comprehensive and the criterion for valuation

is the content but not the length of the answer.

6. (a) Solve for mesh currents using Cramer's rule for the given network below (CO1)

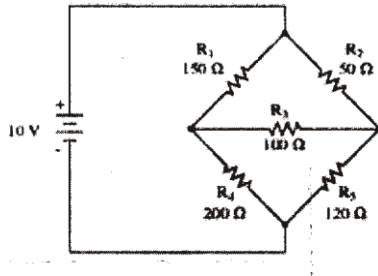

or

- (b) Find the voltage across 2 ohm resistor by using node voltage analysis (CO1)

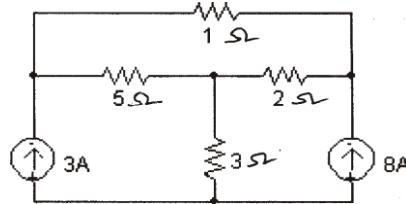

7. (a) Draw the Thevenin's equivalent network for the given network between A and B. (CO2)

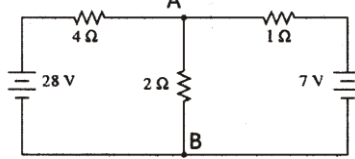

or

- (b) Find the current through 4 ohm resistor by using superposition theorem (CO2)

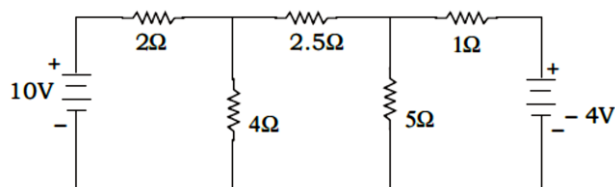

8. (a) Explain star and Delta configurations of resistances (CO3)

or

- (b) Explain the duality of a network (CO1)

-0o0-

(Model Paper) C –20, EC -305
State Board of Technical Education and Training, A. P
Diploma in Electronics and Communication Engineering (DECE)
III Semester

Subject Name: Network Analysis

Sub Code: EC - 305

Time : 90 minutes

Unit Test II

Max.Marks:40

Part-A

16Marks

Instructions: (1) Answer **all** questions.
(2) First question carries **four**marks, each question of remaining carries **three** marks

1. Fill the following blanks with one word
 - a) At resonance the admittance of the parallel RLC circuit is at its maximum and is equal to the conductance of the circuit(**State True/False**) (CO3)
 - b) Laplace transform is useful for studying behaviour of a digital system (**State True/False**) (CO4)
 - c) Constant K filter signal attenuation rate after the cut off point is not very sharp (**State True/False**) (CO5)
 - d) Parallel resonance occurs when the arrangement of components creates the largest impedance.(**State True/False**) (CO3)
2. State the conditions for series resonance (CO3)
3. Define the terms: i) initial conditions; ii) steady state; and iii) transient state (CO4)
4. Write the element model of inductor in time and S-domain. (CO4)
5. Define the terms: neper and decibel (CO5)

Part-B

3×8=24

Instructions: (1) Answer **all** questions.
(2) Each question carries **eight** marks
(3) Answer should be comprehensive and the criterion for valuation is the content but not the length of the answer.

6. (a) A series RLC circuit has a sinusoidal input voltage of 12 V_{peak to peak}. If inductance, L= 20 mH, resistance, R = 80 Ω, and capacitance, C = 400 nF, findthe (i) resonant frequency(ii) Inductive reactance and capacitive reactance at resonant frequency (iii) total current through the circuit at resonant frequency (CO3)

(or)

(b) Given the following parallel resonant circuit find the (i) resonant frequency (ii) Inductive reactance and capacitive reactance at resonant frequency (iii) branch currents at resonant frequency (CO3)

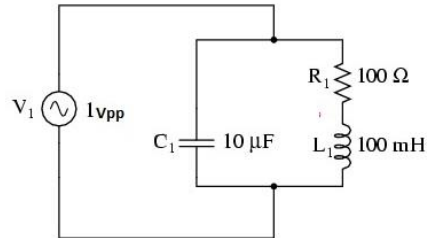

7. (a) Obtain the current expression in S-domain for RLC series circuit using Laplace transform (CO4)

(or)

(b) Obtain the current expression in S-domain for RC series circuit using Laplace transform (CO4)

8. (a) Explain T & π type attenuators with circuit diagram (CO5)

(or)

(b) Design a simple constant K Low Pass π filter with a cut-off frequency of 1KHz (CO5)

BOARD DIPLOMA EXAMINATIONS
C-23, EC-305, NETWORK ANALYSIS
III SEMESTER
MODEL PAPER - SEMESTER END EXAMINATION

TIME:3 HOURS

MAX MARKS:80

Part-A

10×3=30

- Instructions:**
- (1) Answer **all** questions.
 - (2) Each question carries **three** marks
 - (3) Answer should be brief and straight to the point and shall not exceed five simple sentences.

1. Define the terms: branch, node, and loop in circuits (CO1)
2. Write the mesh current equations for the network shown below (CO1)

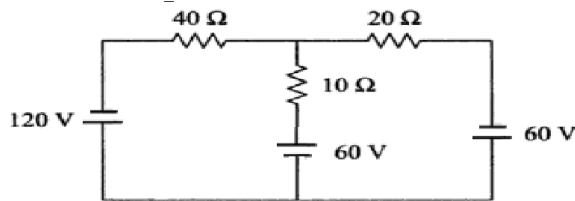

3. Give transformation formulas from Star to Delta (CO2)
4. State superposition theorem (CO2)
5. State the conditions for series resonance (CO3)
6. Compare Series and parallel resonance (CO3)
7. Define the terms: i) initial conditions; ii) steady state; and iii) transient state (CO4)
8. Write Laplace transforms for unit-step function and exponential function. (CO4)
9. List the disadvantages of constant K filters (CO5)
10. Define the terms: neper and decibel (CO5)

Part-B

5×10=50

- Instructions:**
- (1) Answer **any five** questions.
 - (2) Each question carries **10** marks
 - (3) Answer should be comprehensive and the criterion for valuation is the content but not the length of the answer.

11. Solve for mesh currents using Cramer's rule for the given network below (CO1)

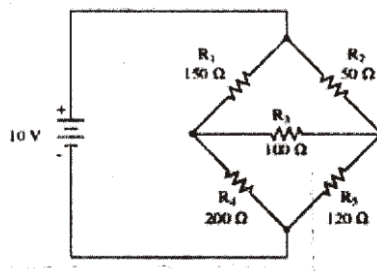

12. Find the voltage across 2 ohm resistor by using node voltage analysis (CO1)

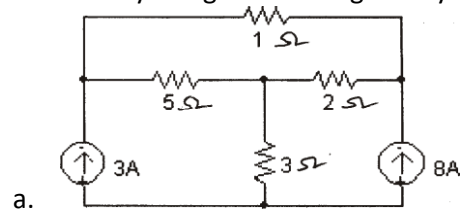

13. Draw the Thevenin's equivalent network for the given network between A and B.(CO2)

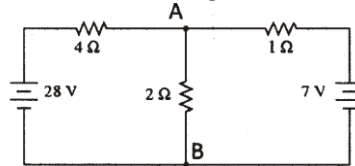

14. Find the current through 4 ohm resistor by using superposition theorem : (CO2)

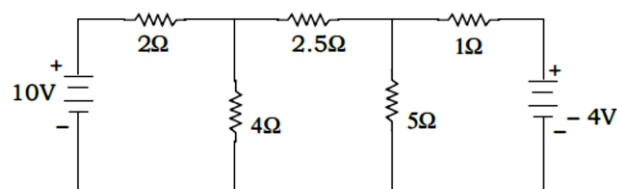

15. A series RLC circuit has a sinusoidal input voltage of 12 V_{peak to peak}. If inductance, $L = 20$ mH, resistance, $R = 80 \Omega$, and capacitance, $C = 400$ nF, find the (i) resonant frequency (ii) Inductive reactance and capacitive reactance at resonant frequency (iii) total current through the circuit at resonant frequency (CO3)

16. Obtain the current expression in S-domain for RLC series circuit using Laplace transform (CO4)

17. Find the voltage $v_o(t)$ in the following circuit using Laplace transform

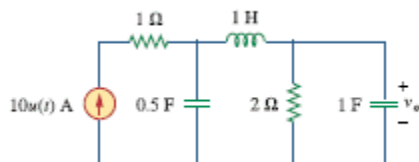

18. Explain T & π type attenuators with circuit diagram (CO5)

PROGRAMMING IN C & MATLAB

Course Code	Course title	No of periods/week	Total no of periods	Marks for FA	Marks for SA
EC-306	PROGRAMMING IN C & MATLAB	04	60	20	80

S No	Unit Title	No. of Periods	COs Mapped
1	C Programming Basics	10	CO1
2	Conditional statements and arrays	12	CO2
3	Strings, Functions & Pointers	13	CO3
4	Structures & unions	12	CO4
5	Basics of MATLAB	13	CO5
	Total	60	

Course Objectives	1. To familiarize with programming in C language and MATLAB
	2. To understand the programming in C language and MATLAB
	3. To learn the practical importance and applications of programming in C language and MATLAB

CO No		COURSE OUTCOMES
CO1	EC-306.1	Describe the basics of C Programming.
CO2	EC-306.2	Explain conditional statements and Arrays of C Programming
CO3	EC-306.3	Analyse the use of strings, functions and pointers C programming.
CO4	EC-306.4	Describe the structures and unions in C-Programming.
CO5	EC-306.5	Describe the basics of MATLAB

CO-PO/PSO MATRIX

CO No	PO1	PO2	PO3	PO4	PO5	PO6	PO7	PSO1	PSO2	PSO3
EC-306.1	3	1			1			3	1	1
EC-306.2	3	2	2		1			3	2	2
EC-306.3	3	2	2		1			3	2	2
EC-306.4	3	2	2		1			3	2	2
EC-306.5	3	2	2	2	1		2	3	2	2
Average	3	1.8	2	2	1		2	3	1.8	1.8

3=strongly mapped

2=moderately mapped

1=slightly mapped

LEARNING OUTCOMES

1.0 C Programming Basics

- 1.1 Give the structure of C program
- 1.2 Mention the character set of C language.
- 1.3 Define the Keywords and list them
- 1.4 List the data types used in C
- 1.5
 - i) Define constants and variables
 - ii) Explain the declaration & initialization of variables.
- 1.6 List the five Arithmetic Operators supported by C
- 1.7 Define an expression and show how to evaluate an Arithmetic Expression
- 1.8
 - i) Define the assignment statement and give the syntax of assignment statement
 - ii) Write the syntax for nested assignment statement
 - iii) List the compound/shorthand assignment operators
- 1.9 Explain the increment and decrement operators.
- 1.10 Explain printf () and scanf () functions with examples.
- 1.11 Mention various type conversion techniques and discuss them
- 1.12 List the four relational operators used in C
- 1.13 Give the operator precedence.
- 1.14 List the three logical operators supported by C
- 1.15 List the three bitwise logical operators

2.0 Conditional Statements and Arrays

- 2.1 Describe the conditional expression
- 2.2 List the four conditional statements supported by C
- 2.3 Write the syntaxes of the following conditional statements and explain
 - i. If
 - ii. If.. else.

- iii. Nested if ...else
- 2.4 Write the syntax of switch case statement and explain.
- 2.5 Write simple programs based on conditional statements.
 - i) Write a program to find whether a given year is leap year or not
 - ii) Write a program to find biggest of three numbers
 - iii) Write a program to check whether a given number is even or odd by using bitwise logical operator
 - iv) Write a program to check whether a given character is vowel or consonant by using switch case statement
 - v) Write a program to perform arithmetic operations using switch case statement
- 2.6 List the three types of iterative statements supported by C
- 2.7 Write the syntaxes of the following iterative statements and explain
 - i. while
 - ii. for
 - iii. do... while
- 2.8 Differentiate while & do while loops
- 2.9 Differentiate break & continue statements
- 2.10 Write the syntax of nested loops and explain
- 2.11 Write programs based on iterative statements.
 - i) Write a program to find sum of n natural numbers
 - ii) Write a program to find sum of digits of a given number
 - iii) Write a program to check whether a given number is Armstrong or not
 - iv) Write a program to print fibonacci series using loops.
 - v) Write a program to print even and odd numbers
 - vi) Write a program to check whether a given number is prime number or not
 - vii) Write a program to print prime numbers between two given numbers
 - viii) Write a program to check whether a given number is PALINDROME or not
- 2.12
 - i) Define an Array.
 - ii) Explain declaration and initialization of One Dimensional Array.
 - iii) Explain accessing the elements in the Array.
- 2.13
 - i) Write a C program to find largest / smallest number in an array
 - ii) Write a C program to sort the numbers in an array in ascending order
 - iii) Write a C program to find sum of elements of an array
- 2.14 Explain declaration and initialization of two Dimensional Arrays.
- 2.15 Write a C program to perform matrix addition/subtraction/Multiplication
- 3.0 Strings, Functions & Pointers**
- 3.1 Define String
- 3.2 Explain different functions used for reading and writing strings with examples
- 3.3 Explain the String manipulation functions strcat(), strcmp(), strcpy() and strlen() with examples.
- 3.4 State the use of function in C

- 3.5 Explain declaration of a function in program
- 3.6 Write the operation of getchar(),getch(),getche() and putchar() functions
- 3.7 State the use of return statement.
- 3.8 Explain passing of parameters to the function
- 3.9 Write simple programs on functions call techniques
- 3.10 Define a pointer.
- 3.11 Declare a pointer, assign a pointer, initialize a pointer
- 3.12 Explain pointer arithmetic operations with examples
- 3.13 Differentiate address and dereferencing operators.

4.0 Structures & unions

- 4.1 Define a structure in C
- 4.2 Write the syntax of structure declaration and explain
- 4.3 Explain the method of declaring a structure variable
- 4.4 Explain the method of initializing a structure variable
- 4.5 Explain the method of accessing of members of a structure
- 4.6 Illustrate structures with a program to read & print a book database consisting of Title of book, author, no. of pages, price as fields
- 4.7 Explain how to find size of a structure
- 4.8 Define a Union
- 4.9 Differentiate between structure and union
- 4.10 State the function of pre-processor directives in C
- 4.11 List the six pre-processor directives.
- 4.12 Explain the conditional pre-processor directives with examples
- 4.13 Explain the unconditional pre-processor directives with examples

5.0 Basics of MATLAB

- 5.1 State the need for MATLAB in solving engineering problems
- 5.2 List the major differences between C and MATLAB
- 5.3 List the arithmetic operators, relational operators, logical operators in MATLAB
- 5.4 Differentiate element wise multiplication/division/power operations and array multiplication/division/power operations
- 5.5 State the usage of
 - i) linspace operator
 - ii) clc,clear,who, whos commands
- 5.6 Give the syntax and usage of decision making statements : i) if...end statement; ii) if..else..end statement used in MATLAB
- 5.7 Give the syntax and usage of loop statements : i) while loop ii) for loop used in MATLAB
- 5.8 Explain the creation 1D & 2D arrays and mXn matrices in MATLAB
- 5.9 Illustrate with an example the matrix operations such as : i) addition ;ii) subtraction; iii) multiplication; iv) transpose and v) inverse using MATLAB
- 5.10 List the common input/output functions in MATLAB.
- 5.11 Illustrate plot commands such as: i) plot(x,y) ;ii) fplot() iii) title(); iv) xlabel(); v) ylabel(); vi) ezplot() vii) subplot() viii) bar() ix) pie() in MATLAB

- 5.12 State the usage of :
- i) SIMULINK
 - ii) GUI

COURSE CONTENT

1. C-Programming Basics

Structure of a C program - Character Set –keywords – Data types -Constants, Variables – Arithmetic operators- evaluation of expression– Assignment statement –Nested assignment statement – Compound assignment operators- Increment, Decrement operators- printf() and scanf() functions – Operator precedence – Relational, Logical, Bitwise logical operators

2. Conditional Statements and arrays

Conditional expression- conditional statements - If, If-else, Nested If else–Switch case statement- iterative statements:-While, for, do-while- Break, Continue -Nested loops - -1D Array declaration, Initialization - 2D Array declaration, Initialization -Accessing of Array elements

3. Strings, Functions & pointers

Define string - Reading and writing strings –String manipulation functions –function call - Return statement, passing parameters to function- Function calls - Pointer declaration- address and dereferencing operators.

4. Structures & Unions

Structure features - structure variable, declaration and Initialization - Accessing of Structure members- Unions -differentiate structure and union – Pre-processor directives

5. Basics of MATLAB

Need for Matlab - Difference between Matlab and C -Arithmetic,relational, logical operators-element wise multiplication/division/power operations and array multiplication/division/power operations –linespaceoperator – clc,clear,who,whos commands-decision making statements - Loop statements –arrays and matrices -working with matrices –input/output functions – plotting commands- SIMULINK-GUI

REFERENCE BOOKS

1. BalaguruSwamy.E, Programming in ANSI C, , 3rd Edition, TMH
2. Kamthane, Programming with ANSI and Turbo C, Pearson Education
3. Gottfried (Schaum Series), Programming in C, McGraw Hill
4. ReemaThareja, Programming in C by, Oxford university press.
5. YashwantKanetkar, Let us C, BPB Publication, New Delhi
6. Pratap,Getting Started with MATLAB: A Quick Introduction for Scientists and Engineers, Oxford University Press
7. Ram N.patel , Ankush mittal,Programing in MATLAB: aproblem solving approach , PERSON

BLUE PRINT

SI No	Unit Title	No of Periods	Weightage Allotted	Weightage of Marks		COs mapped
				No of Essay Questions	No of Short answer Questions	
1	C Programming Basics	10	16	1	2	CO1
2	Conditional statements and arrays	12	26	2	2	CO2
3	Strings, Functions & Pointers	13	26	2	2	CO3
4	Structures & unions	12	16	1	2	CO4
5	Basics of MATLAB	13	26	2	2	CO5
		60	110	80	30	

Table specifying the scope of syllabus to be covered for Unit Tests

Unit Test	Learning outcomes to be covered
Unit Test-I	From 1.1 to 3.10
Unit Test-II	From 3.11 to 5.12

(Model Paper)

C –23, EC -306

State Board of Technical Education and Training, A. P
Diploma in Electronics and Communication Engineering (DECE)

III Semester

Subject Name: Programming in C & MATLAB

Sub Code: EC - 306

Time : 90 minutes

Unit Test I

Max.Marks:40

Part-A

16Marks

Instructions: (1) Answer **all** questions.
(2) First question carries **four** marks, each question of remaining carries **three** marks

1. Fill the following blanks with one word
 - a) _____ symbol represents assignment operator (CO1)
 - b) ++a is the syntax of post increment (State True/False) (CO1)
 - c) Switch case is an example for iterative statement (State True/False) (CO2)
 - d) && symbol represents which operator in C _____ (CO1)
2. List six relational operators in C (CO1)
3. Define an Array. (CO2)
4. Distinguish between break and continue statements. (CO2)
5. Define String (CO3)

Part-B

3×8=24

Instructions: (1) Answer **all** questions.
(2) Each question carries **eight** marks
(3) Answer should be comprehensive and the criterion for valuation is the content but not the length of the answer.

6. (a) Explain the increment and decrement operators (CO1)
or
(b) Explain bitwise logical operators (CO1)
7. (a) Write the syntaxes of the following decision making statements and explain (CO2)
 - iv. If.. else statement
 - v. Nested if ...else statementor
(b) Write the syntaxes of the following loop control statements and explain (CO2)
 - iv. for
 - v. while
8. (a) Write a C program to sort the numbers in an array in ascending order (CO2)
or
(b) Write a C program to perform matrix addition. (CO2)

(Model Paper) **C –23, EC -306**
State Board of Technical Education and Training, A. P
Diploma in Electronics and Communication Engineering (DECE)
III Semester
Subject Name: Programming in C & MATLAB
Sub Code: EC- 306

Time : 90 minutes

Unit Test II

Max.Marks:40

Part-A

16Marks

Instructions: (1) Answer **all** questions.
(2) First question carries **four**marks, each question of remaining carries **three** marks

1. Fill the following blanks with one word
 - a) _____key word is used in the declaration of structure (CO4)
 - b) Pointer is a variable which stores the address of another variable **(State True/False)** (CO3)
 - c) Write any one conditional pre-processor directive (CO4)
 - d) In MATLAB declaration of variables is necessary before we initialize them **(State True/False)** (CO5)
2. Define a pointer (CO3)
3. Define a structure in C (CO4)
4. Differentiate structure and union in any three aspects (CO4)
5. Distinguish the major differences between C and MATLAB (CO5)

Part-B

3×8=24

Instructions: (1) Answer **all** questions.
(2) Each question carries **eight** marks
(3) Answer should be comprehensive and the criterion for valuation is the content but not the length of the answer.

6. a) Explain pointer arithmetic operations with examples. (CO3)
or
(b) Explain passing of parameters to the function (CO3)
7. (a) Explain the method of accessing of members of a structure. (CO4)
or
(b) Illustrate structures with a program to read & print a book database consisting of Title of book, author, no. of pages, price as fields (CO4)
8. (a) Explain with an example the matrix operations such as :i) addition ;ii) subtraction; iii) multiplication; iv) transpose and v) inverse using MATLAB (CO5)
or
(b) Illustrate plot commands such as: i) plot(x,y) ;ii) fplot() iii) title(); iv) xlabel(); v) ylabel(); vi) subplot() in MATLAB

-oOo-

MODEL PAPER
BOARD DIPLOMA EXAMINATIONS
C-23, EC-306, PROGRAMMING IN C & MATLAB
III SEMESTER
SEMESTER END EXAMINATION

TIME:3 HOURS

MAX MARKS:80

Part-A

10×3=30

Instructions: (1) Answer **all** questions.
(2) Each question carries **three** marks
(3) Answer should be brief and straight to the point and shall not exceed five simple sentences.

- | | |
|--|-------|
| 1. List any six relational operators used in C. | (CO1) |
| 2. Write the syntax for nested assignment statement | (CO1) |
| 3. Define an Array. | (CO2) |
| 4. Distinguish between break and continue statements. | (CO2) |
| 5. Define a String | (CO3) |
| 6. Describe the use of return statement in C | (CO3) |
| 7. Define a structure in C | (CO4) |
| 8. Differentiate structure and union in any three aspects | (CO4) |
| 9. State the need for MATLAB in solving engineering problems | (CO5) |
| 10. Distinguish the major differences between C and MATLAB | (CO5) |

Part-B

5×8=40

Instructions: (1) Answer **all** questions.
(2) Each question carries **eight** marks
(3) Answer should be comprehensive and the criterion for valuation is the content but not the length of the answer.

- | | |
|---|-------|
| 11. (i) Explain the increment and decrement operators | (CO1) |
| (ii) Explain bitwise logical operators | (CO1) |
| 12. Write a C program to sort the numbers in an array in ascending order | (CO2) |
| 13. Write a C program to perform matrix addition. | (CO2) |
| 14. Explain the String handling functions strcat(), strcmp(), strcpy() and strlen() with examples. | (CO3) |
| 15. Write a c program to check whether a given number is palindrome or not | (CO3) |
| 16. Explain the method of accessing of members of a structure. | (CO4) |
| 17. Explain with an example the matrix operations such as : i) addition ;ii) subtraction;
iii) multiplication; iv) transpose and v) inverse using MATLAB | (CO5) |
| 18. Illustrate plot commands such as: i) plot(x,y) ;ii) fplot() iii) title(); iv) xlabel(); v) ylabel();
vi) subplot() in MATLAB | (CO5) |

-o0o-

Electronic Circuits-I & Network Analysis Lab

Course Code	Course title	No of periods/week	Total no of periods	Marks for FA	Marks for SA
EC-307	Electronic Circuits-I & Network Analysis Lab	4	60	40	60

S No	Unit Title	No. of Periods	COs Mapped
1	Rectifiers and Power supplies	16	CO1
2	Amplifiers and oscillators	16	CO2
3	Resonance and Network Theorems	16	CO3
4	Circuit simulation using Pspice or equivalent	12	CO4
	TOTAL	60	

Course Objectives	1. To construct and measure various parameters of rectifiers.
	2 To construct and measure various parameters of amplifiers and Oscillators.
	3.To construct and verify the network theorems
	4. To simulate rectifiers, amplifiers and Oscillator circuits using simulation software.

CO No		COURSE OUTCOMES
CO1	EC-307.1	Construct the rectifiers and obtain different parameters.
CO2	EC-307.2	Construct the Amplifiers and obtain different parameters. Construct Oscillators, obtain output waveform and calculate output frequency.
CO3	EC-307.3	Construct the circuits for different theorems and verify
CO4	EC-307.4	Simulate rectifiers, amplifiers and Oscillators using P-spice or equivalent.

CO-PO/PSO MATRIX

CO No	PO1	PO2	PO3	PO4	PO5	PO6	PO7	PSO1	PSO2	PSO3
EC-307.1	3	2	2	1	1	2		3	1	2
EC-307.2	3	2	2	1	1	2		3	1	2
EC-307.3	3	2	2	1	1	2		3	1	2
EC-307.4	3	2	2	3			2	3	3	3
Average	3	2	2	1.5	1	2	2	3	1.5	2.25

3=strongly mapped
2=moderately mapped
1=slightly mapped

LEARNING OUTCOMES:

1.0 Rectifiers and Power supplies

1. Obtain output waveforms and measure DC o/p voltage, ripple voltage of a Bridge rectifier with/ without filter at different loads and compare with that of theoretical values
2. Obtain the voltage regulation characteristics of Zener regulator
3. Obtain the voltage regulation characteristics of IC regulator (78XX,79XX,LM317)
4. Construct and test the regulated power supply for any given DC voltage using 78XX/79XX

2.0 Amplifiers and Oscillators

5. (i)Plot the frequency response characteristics of a transformer coupled CE Amplifier
(ii)Plot the frequency response characteristics of a RC coupled Amplifier
6. Implement Colpitt's oscillator/Hartley oscillator and verify the effect of varying the tank circuit component values and observe output waveforms on CRO.
7. Construct Crystal oscillator and observe output waveforms on CRO
8. Construct RC Phase shift oscillator and verify the effect of varying the RC component values and observe output waveforms on CRO

3.0 Resonance and Network Theorems

9. Construct RLC series resonance circuit and draw its frequency response
10. Construct a parallel resonance circuit and draw its frequency response
11. Perform an experiment to verify super position theorem
12. Perform an experiment to verify maximum power transfer theorem.

4.0 Circuit simulation using PSPICE or equivalent software

13. Simulate Zener regulator circuit and assess the performance for various loads
14. Simulate of CE amplifier and observe the effect of disconnecting bypass capacitor
15. Simulate RC phase shift oscillator circuit and observe the effect of change in component values

Digital Electronics lab

Course Code	Course title	No of periods/week	Total no of periods	Marks for FA	Marks for SA
EC-308	Digital Electronics lab	3	45	40	60

S No	Unit Title	No. of Periods	COs Mapped
1	Logic Gates	6	CO1
2	Combinational logic circuits	15	CO2
3	Sequential Logic Circuits	15	CO3
4	Practice Using PspiceOrcad Tool Software	09	CO4
	TOTAL	45	

Course Objectives	1. To construct different combinational, sequential logic circuits and obtain truth tables..
	2. To simulate combinational and sequential logic circuits using simulation software
	3. To learn the practical importance of Digital Electronic Circuits.

CO No		COURSE OUTCOMES
CO1	EC-308.1	Test the truth tables of logic gates.
CO2	EC-308.2	Construct combinational logic circuits and verify truth tables.
CO3	EC-308.3	Construct Sequential logic circuits and verify truth tables.
CO4	EC-308.4	Simulate combinational and sequential logic circuits using P-spice or equivalent.

CO-PO/PSO MATRIX

CO No	PO1	PO2	PO3	PO4	PO5	PO6	PO7	PSO1	PSO2	PSO3
EC-308.1	3	1	2		2	2		3		2
EC-308.2	3	2	2		2	2		3	2	2
EC-308.3	3	2	2		2	2		3	2	2
EC-308.4	3	2	2	3			3	3	3	2
Average	3	1.75	2	3	2	2	3	3	2.3	2

3=strongly mapped 2=moderately mapped 1=slightly mapped

LEARNING OUTCOMES:

Logic Gates

1. Verify the truth tables of AND, OR, NOT, NAND, NOR, XOR Gates
2. Realize AND, OR, NOT, XOR gates using 2 input NAND and NOR Gates

Combinational logic circuits

3. Implement Half adder and full adder circuits using TTL/CMOS gates, and verify the truth tables
4. Verify the function of 4-bit magnitude comparator 7485 IC
5. Verify the truth table of Multiplexer IC 74153/74151 etc.
6. Verify the truth table of BCD to 7 segment Decoder 7448 IC
7. Verify the Truth table of 74148 Encoder & 74138 Decoder IC

Sequential Logic Circuits

8. Verify the truth tables RS, JK, T and D Flip-flops
9. Construct a ripple counter using JK-FFs and obtain its timing waveforms
10. Verify the function of 7490 as decade and modulus counter, obtain timing waveforms.
11. verify the function of up/down counter using 74190/ 74193, change the modulus of the counter and verify
12. Verify the function of shift register (ICs like 7495, 74194 etc.)

Practice Using PSPICE Software

13. Simulate AND, OR, NOT, EX-OR Gates Using Universal Gates (ICs 7400 and 7402).
14. Simulate Half Adder And Full Adder Circuits Using ICs 7408, 7486, and 7432
15. Simulate 8×1 Multiplexer Using IC 74153

-0o0-

Analog and Digital Communication systems Lab

Course Code	Course title	No of periods/week	Total no of periods	Marks for FA	Marks for SA
EC-309	Analog and Digital Communication systems Lab	3	45	40	60

S No	Unit Title	No. of Periods	COs Mapped
1	Analog Communication	15	CO1
2	Digital Communication	18	CO2
3	Simulation of Analog Communication systems using PSPICE or equivalent software	6	CO3
4	Simulation of Digital Communication systems using PSPICE or equivalent software	6	CO4
	TOTAL	45	

Course Objectives	1. To familiarisation with analog and digital modulation and demodulation techniques.
	2. To simulate Analog and Digital modulation circuits using simulation software.
	3. To learn the practical importance of Analog and Digital modulation.

CO No		COURSE OUTCOMES
CO1	EC-309.1	Construct AM, FM, PAM, PWM, PPM modulation and demodulation circuits and observe waveforms.
CO2	EC-309.2	Construct PCM, ASK, FSK, PSK modulator and demodulation circuits and TDM, FDM circuits and observe waveforms.
CO3	EC-309.3	Simulate Analog modulation circuits using P-spice or equivalent.
CO4	EC-309.4	Simulate Digital modulation circuits using P-spice or equivalent.

CO-PO/PSO MATRIX

CO No	PO1	PO2	PO3	PO4	PO5	PO6	PO7	PSO1	PSO2	PSO3
EC-309.1	3	3	2		2	3		3	1	2
EC-309.2	3	3	2		2	3		3	1	2
EC-309.3	3	3	2	3			3	3	3	2
EC-309.4	3	3	2	3			3	3	3	2
Average	3	3	2	3	2	3	3	3	2	2

3=strongly mapped

2=moderately mapped

1=slightly mapped

ANALOG COMMUNICATION

1. Conduct an experiment to observe AM waveform and determine Modulation index using CRO.
2. Conduct an experiment to observe FM waveform.
3. Verify and observe Pulse amplitude modulation and demodulation waveforms on CRO
4. Verify and observe Pulse Width modulation and demodulation waveforms on CRO
5. Observe pulse position modulation and demodulation waveforms on CRO

DIGITAL COMMUNICATION

6. Set up a Pulse code modulator/ Demodulator circuit and observe the waveforms.
7. Set up an ASK modulator and demodulator and observe the waveforms.
8. Set up an FSK modulator and demodulator and observe the waveforms
9. Set up a PSK modulator and demodulator and observe the waveforms
10. Perform an experiment on Time Division Multiplexing/ De-multiplexing circuit and observe the waveforms.
11. Perform an experiment on Frequency Division Multiplexing/ De-multiplexing circuit and observe the waveforms.

Simulation using PSPICE or equivalent software

12. Connect a circuit to generate AM waveform and determine Modulation index
13. Connect a circuit to generate Pulse amplitude modulation and observe waveforms
14. Connect a circuit to generate Pulse Width modulation and observe waveforms
15. Set up an ASK modulator and demodulator and observe the waveforms.
16. Set up an FSK modulator and demodulator and observe the waveforms

-0o0-

Programming in C & MATLAB Practice Laboratory

Course Code	Course title	No of periods/week	Total no of periods	Marks for FA	Marks for SA
EC-310	Programming in C & MATLAB Practice Laboratory	03	45	40	60

S No	Unit Title	No. of Periods	COs Mapped
1	C compiler Basics, programs on Decision & Loop Control Statements	9	CO1
2	Programs on functions, Arrays, Strings in C	9	CO2
3	Programs on Pointers, Structures and Unions in C	9	CO3
4	MAT Lab Practice	18	CO4
Total		45	

Course Objectives	1. To familiarize with programming in C and MATLAB
	2. To understand the programming concepts of C and MATLAB
	3. To learn the practical importance and applications of programming in C and MATLAB.

CO No		COURSE OUTCOMES
CO1	EC-310.1	Describe the usage of C Compiler, programs on Decision & Loop Control Statements
CO2	EC-310.2	Apply functions , arrays and strings in C language
CO3	EC-310.3	Apply pointers, structures and unions in C Language.
CO4	EC-310.4	Practice on basics of MATLAB.

CO-PO/PSO MATRIX

CO No	PO1	PO2	PO3	PO4	PO5	PO6	PO7	PSO1	PSO2	PSO3
EC-310.1	3	2	2					3	1	
EC-310.2	3	2	2		1			3	1	1
EC-310.3	3	2	2		1			3	1	1
EC-310.4	3	2	2	3	1		3	3	3	1
Average	3	2	2	3	1		3	3	1.5	1

3=strongly mapped

2=moderately mapped

1=slightly mapped

LEARNING OUTCOMES:

I. C Programming Basics

1. Familiarize with turbo C Compiler or equivalent compiler features
2. Practice formatted Input / Output (printf and scanf) functions.
3. Practice with various operators in C

II. Decision & Loop Control Statements

4. Practice with decision & control (if, if-else, nested if –else) Statements
5. Practice with decision control (Switch –case structure) statements
6. Practice with loop control Statements

III. Exercises on functions

7. Practice the use of functions in C

IV. Arrays, Strings and Pointers in C

8. Write and run small programs using single dimensional integer arrays
9. Write and run small programs using multidimensional integer arrays
10. Write and run small programs using string functions for string comparison, copying and concatenation
11. Write and run small programs using with pointers in 'C'

V. Structures and Unions

12. Write and run small programs using Structures& Unions in C

VI. MAT LAB PRACTICE

13. Familiarize with MATLAB Compiler environment, command line arguments, HELP and know about various tool boxes available in MATLAB
14. Write simple programs on decision making statements (if-end, if-else-end, nested if –else-end)
15. Write simple programs on loop control statements (while , for loops)
16. Write simple programs to create simple 1D & 2D arrays and perform addition & subtraction operations
17. Write simple programs to create 3X3 matrixes and perform : i) addition ;ii) subtraction; iii) multiplication; iv) transpose and v) inverse operations
18. Write simple programs to illustrate plot commands such as: i) plot(x,y) ;ii) fplot() iii) title(); iv) xlabel(); v) ylabel(); vi) legend() in MATLAB
19. Know the procedure to convert MATLAB program to C code

-0o0-

IV Semester

FOURTH SEMESTER**DIPLOMA IN ELECTRONICS & COMMUNICATION ENGINEERING
SCHEME OF INSTRUCTIONS AND EXAMINATIONS
IV SEMESTER**

Subject Code	Name of the Subject	Instruction period / week		Total Period / Sem	Scheme of Examination			
		Theory	Practical/Tutorial		Duration (hours)	Sessional Marks	End Exam Marks	Total Marks
THEORY								
EC- 401	Electronic Circuits-II	5	-	75	3	20	80	100
EC - 402	Microcontrollers and Interfacing	5	-	75	3	20	80	100
EC-403	Microwave & Satellite Communication systems	5	-	75	3	20	80	100
EC-404	IoT and Sensors	4	-	60	3	20	80	100
EC-405	Digital Logic Design through Verilog HDL	5	-	75	3	20	80	100
PRACTICAL								
EC - 406	Electronic Circuits-II Lab	-	3	45	3	40	60	100
EC - 407	Microcontrollers and Interfacing Lab	-	3	45	3	40	60	100
EC - 408	Communication skills	-	3	45	3	40	60	100
EC – 409	IoT and Sensors Lab	-	3	45	3	40	60	100
EC-410	Verilog HDL Lab	-	3	45	3	40	60	100
	Activities		3	45	-	-	-	-
TOTAL		24	18	630	-	300	700	1000

ELECTRONIC CIRCUITS -II

Course Code	Course title	No of periods/week	Total no of periods	Marks for FA	Marks for SA
EC-401	ELECTRONIC CIRCUITS -II	05	75	20	80

S No	Unit Title	No. of Periods	COs Mapped
1	Wave shaping Circuits	15	CO1
2	Linear Integrated Circuits	15	CO2
3	Op-Amp Applications	20	CO3
4	Timers and PLL	13	CO4
5	A/D & D/A Converters	12	CO5
	TOTAL	75	

Course Objectives	1. To learn the principles and working of Linear ICs, A/D and D/A converters and wave shaping circuits.
	2. To analyze the applications of linear ICs.
	3. To learn the practical importance of Linear ICs and wave shaping circuits

CO No	COURSE OUTCOMES
CO1	EC-401.1 Describe different wave shaping circuits.
CO2	EC-401.2 Describe IC manufacturing technologies and principles of OP-AMP
CO3	EC-401.3 Analyse the OP-Amp application circuits.
CO4	EC-401.4 Analyse the timer and PLL circuits.
CO5	EC-401.5 Describe Analog to Digital and Digital to Analog converters.

CO-PO/PSO MATRIX

CO No	PO1	PO2	PO3	PO4	PO5	PO6	PO7	PSO1	PSO2	PSO3
EC-401.1	3	3	3	1	1			3	1	1
EC-401.2	3	3	3	2	1			3	2	1
EC-401.3	3	3	3	3	3		1	3	3	3
EC-401.4	3	3	3	3	3		1	3	3	2
EC-401.5	3	3	3	3	3		1	3	3	3
Average	3	3	3	2.4	2.2		1	3	2.4	2

3=strongly mapped, 2=moderately mapped, 1=slightly mapped

LEARNING OUTCOMES:

1.0 Wave Shaping Circuits

- 1.1 Explain the need of wave shaping circuits
- 1.2 List different linear and non-linear wave shaping circuits
- 1.3 Explain RC differentiator circuit with wave forms
- 1.4 Explain RC integrator circuit with wave forms
- 1.5 Give the classification of clippers
- 1.6 Explain the working of different unbiased diode clipper circuits
- 1.7 Explain the working of different biased diode clipper circuits
- 1.8 Explain the double ended diode clipper with waveforms
- 1.9 Explain the working of transistor clipper with wave forms
- 1.10 Explain the working of Zener diode clipper with wave forms
- 1.11 Explain the working of clamper circuit
- 1.12 List the applications of clippers and clampers

2.0 Linear Integrated Circuits

- 2.1 List the advantages and disadvantages of Integrated Circuits over discrete circuits.
- 2.2 Distinguish between linear and digital ICs
- 2.3 Classify ICs based on manufacturing process (monolithic, thin film, thick film and hybrid).
- 2.4 i) List different IC packages.
ii) Draw the shape of above package types
- 2.5 State various levels of integration (SSI, MSI, LSI, VLSI etc.,).
- 2.6 i) State the features of Surface Mount Technology (SMT)
ii) List any 6 merits of SMT Technology.
- 2.7 Explain the working of differential amplifier constructed using BJTs.
- 2.8 i) Explain the functional block diagram of an operational amplifier.
ii) Draw the circuit symbol of an operational amplifier.
- 2.9 i) List the characteristics of ideal operational amplifier.
ii) Define the terms: Input impedance, Open loop gain, Slew rate, CMRR, Input offset voltage, Input offset Current and give the typical values of each.
- 2.10 Draw the pin diagram of IC 741 and state the function of each pin
- 2.11 State the concept of virtual ground.
- 2.12 i) Explain the function of Op Amp as Inverting amplifier with a circuit diagram.
ii) Derive the expression for voltage gain of Inverting amplifier
- 2.13 i) Explain the Non Inverting amplifier configuration of Op Amp.
ii) Derive the equation for Voltage gain of the Non Inverting amplifier

3.0 Op-Amp Applications

- 3.1 Explain the function of OP-Amp as: i) Summer ii) Scale changer
iii) Integrator and iv) Differentiator
- 3.2 Explain the working of OP-Amp based Wein-bridge Oscillator circuit
- 3.3 Give the conditions required for stable operation of above circuit
- 3.4 Explain the working of OP-Amp based RC Phase shift oscillator circuit
- 3.5 Define Sweep Voltage and state its use as time-base
- 3.6 Distinguish between voltage and current time-base generators and list their applications.
- 3.7 Explain the working of OP-Amp based Bootstrap sweep circuit.
- 3.8 Explain the working of OP-Amp based Miller sweep circuit

- 3.9 Explain the working of OP-Amp based Astable multi-vibrator with waveforms.
- 3.10 Explain the working of OP-Amp based Monostable multi-vibrator with waveforms
- 3.11 Explain the working of OP-Amp based Schmitt trigger circuit with waveforms
- 3.12 Explain the Voltage to current converter circuit.
- 3.13 List any three applications of Voltage to current converter.
- 3.14 i) Explain the Current to Voltage converter circuit.
ii) List any three applications of Current to Voltage converter.

4.0 Timers and PLL

- 4.1 Draw the pin diagram of 555 IC and state the function of each pin
- 4.2 Draw the internal block diagram of 555 IC and explain the function of each block.
- 4.3 Draw the circuit of astable multi-vibrator using 555 IC and explain its working
- 4.4 Explain the concept of Phase locked loop
- 4.5 Draw internal block diagram of PLL – LM565 and explain its working
- 4.6 Explain the operation of VCO (LM566)
- 4.7 Define lock range of PLL
- 4.8 Define capture range of PLL.
- 4.9 List any three applications of PLL
- 4.10 Explain frequency multiplier and FM demodulator using PLL

5.0 A/D & D/A Converters.

- 5.1 State the need for A/D and D/A conversion.
- 5.2 Define the terms resolution, Accuracy, Monotonicity and settling time of D/A converter.
- 5.3 Explain D/A conversion using binary weighted resistors.
- 5.4 Explain D/A conversion using R-2R ladder network.
- 5.5 Explain A/D conversion using counter method.
- 5.6 Explain A/D conversion using successive approximation method
- 5.7 List IC numbers of any three ADCs
- 5.8 List IC numbers of any three DACs

COURSE CONTENTS:

1. Wave Shaping Circuits

Need of wave shaping circuit- Linear and non-linear wave shaping networks - RC differentiator circuit - wave forms - RC integrator circuit - wave forms - classification of clippers - working of biased and un biased diode clipper circuits – Transistor clipper circuits – Zener diode clipper circuits - clamper circuit - applications of clippers and clampers

2. Linear Integrated Circuits

advantages and disadvantages of Integrated circuits over discrete circuits- Distinguish linear, digital ICs- Classifications of ICs based on manufacturing process -IC packages –Levels of integration – SMT- - Operational amplifiers– circuit symbol –block diagram – Input impedance, Open loop gain, Slew rate, CMRR, Input offset voltage, Input offset Current – IC 741- Pin diagram- Virtual ground — OpAmp as inverting amplifier & Non inverting amplifier

3. **Op-Amp Applications**—OP-Amp as summer, scale changer, integrator, differentiator- Wein bridge oscillator –RC Phase shift oscillator - Voltage and current time base generators- Bootstrap & Miller sweep circuits – Astable, Monostable multivibrators- Schmitt trigger— Voltage to current converter- applications – current to voltage converter- Applications
- 4 **Timers and PLL**
555 IC Pin diagram- Internal block diagram - 555 Timer as Astable Multivibrator – Phase locked loop –PLL-LM 565 block diagram & working- voltage Control Oscillators(LM 566) – Lock range of PLL – Capture range of PLL – Design rules for PLL – applications - frequency multiplier and FM demodulator using PLL
- 5 **A/D & D/A Converters**
Need for A/D and D/A conversion -Resolution, Accuracy, Monotonicity and settling time of D/A converter - D/A conversion using binary weighted resistors , R-2R ladder network - A/D conversion using counter method and successive approximation method - IC numbers of any three ADCs, DACs

REFERENCE BOOKS

1. Bogart, Electronic Devices and Circuits, TMH
2. Milliman and Hallkias, Integrated Electronics , TMH
3. Ramakanth A.Gaykwad, Opamps & Linear Integrated Circuits, 4th edition, PRENTICE Hall
4. D Roy Chowdary, Linear Integrated Circuits, 4th edition,
5. George Clayton, Operational Amplifiers, 5th edition, Newnes
6. Willam D. Stanley ,Operational Amplifiers with Linear Integrated Circuits, 4th Edition , PEARSON
7. Dr.Sanjay sarma, OPamps & LIC ,Katsonbooks
8. Johanhuijsing, Operational Amplifiers theory & Design, 3rd Edition, SPRINGER Publications

BLUE PRINT

SI No	Unit Title	No of Periods	Weightage Allotted	Weightage of Marks		COs mapped
				No of Essay Questions	No of Short answer Questions	
1	Wave shaping Circuits	15	23	2	1	CO1
2	Linear Integrated Circuits	15	19	1	3	CO2
3	Op-Amp Applications	20	26	2	2	CO3
4	Timers and PLL	13	26	2	2	CO4
5	A/D & D/A Converters	12	16	1	2	CO5
		75	110	80	30	

Table specifying the scope of syllabus to be covered for Unit Tests

Unit Test	Learning outcomes to be covered
Unit Test-I	From 1.1 to 3.8
Unit Test-II	From 3.9 to 5.8

(Model Paper) **C –23, EC-401**
State Board of Technical Education and Training, A. P
Diploma in Electronics and Communication Engineering (DECE)
IV Semester

Subject Name: Electronic circuits II

Sub Code: EC- 401

Time : 90 minutes

Unit Test-I

Max.Marks:40

Part-A

16Marks

Instructions: (1) Answer **all** questions.
(2) First question carries **four** marks, each question of remaining carries **three** marks

1. Fill the following blanks with one word
 - a) The output wave form shape of non linear wave shaping circuit is same as input wave form (State True/False) (CO1)
 - b) Draw RC differentiator circuit (CO1)
 - c) What is the input impedance of ideal OPAMP (CO2)
 - d) What is the open loop gain of ideal OPAMP (CO2)
2. List different linear and non-linear wave shaping circuits (CO1)
3. Define CMRR and Slew rate for OP-AMP (CO2)
4. Distinguish between linear and digital ICs (CO2)
5. Define sweep voltage (CO3)

Part-B

3×8=24

Instructions: (1) Answer **all** questions.
(2) Each question carries **eight** marks
(3) Answer should be comprehensive and the criterion for valuation is the content but not the length of the answer.

6. (a) Explain the working of transistor clipper with wave forms (CO1)
(or)
(b) Explain RC integrator circuit with wave forms (CO1)
7. (a) Explain the working of differential amplifier constructed using BJTs. (CO2)
(or)
(b) Explain the function of Op Amp as Inverting amplifier with a circuit diagram. (CO2)
8. (a) Explain the working of OP-Amp based RC-phase shift oscillator circuit (CO3)

or
(b) Explain the working of OP-Amp based Bootstrap sweep circuit (CO3)

(Model Paper) C –23, EC-401
State Board of Technical Education and Training, A. P
Diploma in Electronics and Communication Engineering (DECE)
IV Semester
Subject Name: Electronic circuits II
Sub Code: EC - 401

Time : 90 minutes

Unit Test II

Max.Marks:40

Part-A

16Marks

Instructions: (1) Answer **all** questions.
(2) First question carries **four** marks, each question of remaining carries **three** marks

1. Fill the following blanks with one word
 - a) It is an active circuit which converts an analog input signal to a digital output signal
(State True/False) (CO5)
 - b) In 555 IC which pin provides a discharge path from the timing capacitor to ground when the output is low (CO4)
 - c) What is the function of LM566 IC_____ (CO4)
 - d) Binary weighted resistors method is used for Analog to Digital conversion
(State True/False) (CO5)
2. List any 3 applications of voltage to current converter (CO3)
3. Define lock range of PLL (CO4)
4. Give the pin configuration of 555 IC (CO4)
5. Describe the need for A/D and D/A conversion. (CO5)

Part-B

3×8=24

- Instructions:** (1) Answer **all** questions.
(2) Each question carries **eight** marks
(3) Answer should be comprehensive and the criterion for valuation is the content but not the length of the answer.
6. (a) Explain the working of OP-Amp based monostable multivibrator circuit with waveforms (CO3)

or

(b) Explain the working of OP-Amp based Schmitt trigger circuit with waveforms (CO3)
 7. (a) Draw internal block diagram of PLL – LM565 and explain its working (CO4)

or

(b) Explain frequency multiplier and FM demodulator using PLL (CO4)
 8. (a) Explain D/A conversion using R-2R ladder network. (CO5)

or

(b) Explain A/D conversion using successive approximation method (CO5)

MODEL PAPER
BOARD DIPLOMA EXAMINATIONS
C-23, EC-401, ELECTRONIC CIRCUITS-II
IV SEMESTER
SEMESTER END EXAMINATION

TIME:3 HOURS

MAX MARKS:80

Part-A

10×3=30

Instructions: (1) Answer **all** questions.
(2) Each question carries **three** marks
(3) Answer should be brief and straight to the point and shall not exceed five simple sentences.

1. Give the classification of clippers (CO1)
2. Distinguish between linear and digital ICs (CO2)
3. List different IC packages. (CO2)
4. State various levels of integration (CO2)
5. Distinguish between voltage and current time-base generators (CO3)
6. List any three applications of current to voltage converter (CO3)
7. Define lock range of PLL (CO4)
8. Give the pin configuration of 555 IC (CO4)
9. List IC numbers of any three DACs (CO5)
10. Describe the need for A/D and D/A conversion. (CO5)

Part-B

5×8=40

Instructions: (1) Answer **any five** questions.
(2) Each question carries **10** marks
(3) Answer should be comprehensive and the criterion for valuation is the content but not the length of the answer.

11. Explain the working of transistor clipper with wave forms (CO1)
12. Explain RC integrator circuit with wave forms (CO1)
13. Explain the function of Op Amp as Inverting amplifier with a circuit diagram. (CO2)
14. Explain the working of OP-Amp based Miller sweep circuit. (CO3)
15. Explain the working of OP-Amp based Schmitt trigger circuit with waveforms (CO3)
16. Draw internal block diagram of 555 IC and explain the function of each block (CO4)
17. Explain frequency multiplier and FM demodulator using PLL (CO4)
18. Explain A/D conversion using successive approximation method (CO5)

-0o0-

MICROCONTROLLERS AND INTERFACING

Course Code	Course title	No of periods/week	Total no of periods	Marks for FA	Marks for SA
EC-402	MICROCONTROLLERS AND INTERFACING	05	75	20	80

S No	Unit Title	No. of Periods	COs Mapped
1	Architecture of Microcontroller 8051	20	CO1
2	Instruction set of 8051 micro controller	15	CO2
3	8051 Programming Concepts	15	CO3
4	Interfacing Simple I/O devices	15	CO4
5	Programming in Embedded C	10	CO5
	Total	75	

Course Objectives	1. To familiarize with various microcontrollers
	2. To understand the programming and applications of 8051 microcontrollers
	3. To learn the practical importance and applications of Microcontrollers.

CO No	COURSE OUTCOMES	
CO1	EC-402.1	Describe the Architecture of 8051 microcontroller
CO2	EC-402.2	Explain the instruction set of 8051 microcontroller
CO3	EC-402.3	Analyze 8051 programming for Arithmetic and Logical operations
CO4	EC-402.4	Describe the Interfacing techniques of I/O devices with 8051 micro controller.
CO5	EC-402.5	Analyze 8051 programming using Embedded C.

CO-PO/PSO MATRIX

CO No	PO1	PO2	PO3	PO4	PO5	PO6	PO7	PSO1	PSO2	PSO3
EC-402.1	3							3		
EC-402.2	3	3						3		
EC-402.3	3	3	3		3			3	3	3
EC-402.4	3	3	3		3		2	3	3	3
EC-402.5	3	3	3		3		3	3	3	3
Average	3	3	3		3		2.5	3	3	3

3=strongly mapped 2=moderately mapped 1=slightly mapped

LEARNING OUTCOMES:

1.0 Architecture of Microcontroller 8051

1.1 List the features of micro controllers.

- 1.2 Compare microprocessors and microcontrollers
- 1.3 Give the details of 8051 microcontroller family chips
- 1.4 Draw the functional block diagram of 8051 microcontroller and state the function of each block
- 1.5 Draw the pin diagram of 8051 micro controller and specify the purpose of each pin
- 1.6 Explain the internal memory organization of 8051 with suitable diagram
- 1.7 Explain the external memory organization of 8051
- 1.8 List various special function registers of 8051 and state their functions
- 1.9 Explain PSW register of 8051
- 1.10 Explain the SFRs associated with timer/counters of 8051
- 1.11 Explain the modes of operations of counters & timers in 8051
- 1.12 List the interrupts of 8051
- 1.13 Explain the SFRs associated with interrupts of 8051
- 1.14 Explain the SFRs associated with serial communication of 8051
- 1.15 List the modes of operation of serial communication with 8051
- 1.16 Describe various I/O ports of 8051

2.0 Instruction set of 8051 micro controller

- 2.1 State the need for an instruction set
- 2.2 Mention the instruction format of 8051
- 2.3 State the terms operation code, operand and illustrate these terms by writing an instruction
- 2.4 Define fetch cycle, execution cycle and instruction cycle.
- 2.5 Distinguish between machine cycle and T-state.
- 2.6 Define the terms machine language, assembly language, and mnemonics.
- 2.7 Classify the 8051 instructions into one byte, two byte and three byte instructions
- 2.8 Classify the 8051 instructions based on their function
- 2.9 List the various addressing modes of 8051 and explain them with examples.
- 2.10 Explain various data transfer group of instructions of 8051 with examples
- 2.11 Explain various arithmetic instructions of 8051
- 2.12 State the effect of arithmetic operations on flags of 8051 with examples
- 2.13 Explain the logic instructions and recognize the flags that are set or reset for given data conditions
- 2.14 List various bit manipulation instructions of 8051 and illustrate with examples
- 2.15 Explain unconditional jump instructions of 8051
- 2.16 Explain conditional jump instructions of 8051
- 2.17 Explain CALL and RET instructions of 8051
- 2.18 State the use of NOP instruction of 8051

3.0 8051 Programming Concepts using assembly language

- 3.1 List the various symbols used in drawing flow charts
- 3.2 Write programs in 8051 assembly language to illustrate the application of data copy instructions
- 3.3 Write programs in 8051 assembly language to perform single byte and double byte addition and subtraction.
- 3.4 Write programs in 8051 assembly language which use jump instructions
- 3.5 Write a delay subroutine to introduce time delay of given time period (in milliseconds) without using 8051 internal timer.
- 3.6 Write a program to introduce time delay of given time period (in milliseconds) using 8051 internal timer.
- 3.7 Define a subroutine and state its use.

- 3.8 Explain the sequence of program when subroutine is called and executed.
- 3.9 Explain information exchange between the program counter and the stack and identification of stack pointer register when a subroutine is called and executed.
- 3.10 Illustrate PUSH, POP instructions with an example.
- 3.11 Define the term debugging a program
- 3.12 Explain the principles of single step and break point debugging techniques

4.0 Interfacing Simple I/O devices

- 4.1 Explain the Interfacing concepts of push button switches and LEDs with 8051
- 4.2 Draw a diagram to connect an LED to a port pin and Write an 8051 assembly language program to blink it with a given time delay.
- 4.3 Interface a common cathode/anode seven segment display with 8051 and write a program to display a given decimal number
- 4.4 List reasons for the popularity of LCDs
- 4.5 State the functions of pins of 16x2 LCD module
- 4.6 List the instruction command codes for programming 16x2 LCD module
- 4.7 Explain Interfacing of 16x2 LCD module to 8051
- 4.8 Write an 8051 ALP to display a given message on 16x2 LCD module
- 4.9 Describe key bouncing problem and de-bouncing solutions
- 4.10 Explain the Interfacing concepts of a 4x4 Matrix Key Board with 8051 with diagram
- 4.11 Explain the interfacing concepts of stepper motor with 8051 and write a program to run the motor continuously
- 4.12 Interface 8051 with Relay to drive a lamp

5.0 Programming using Embedded C

- 5.1 List the differences between C and Embedded C
- 5.2 List the reasons for writing programs in Embedded C
- 5.3 Explain the C data types for 8051
- 5.4 Write an 8051 C program to store the data in the accumulator
- 5.5 Write a program to load three numbers into Accumulator and send them to port 1
- 5.6 Write an 8051 C program to send values 00 – FF to port P1
- 5.7 Write an 8051 C program to toggle all the bits of P1 continuously.
- 5.8 Write an 8051 C program to toggle bits of P1 ports continuously with 250 ms.
- 5.9 Write a C program for 8051 to transfer the letter "A" serially at 9600 baud continuously. Use 8-bit data and 1 stop bit.
- 5.10 Write an 8051 C program to toggle all the bits of port P1 continuously with some delay in between. Use Timer 0, 16-bit mode to generate the delay.

COURSE CONTENTS:

1. Architecture of Microcontroller 8051

Features of micro controllers, Compare Microprocessors and Microcontrollers, block diagram of 8051 microcontroller, pin diagram of 8051 microcontroller, internal memory & external memory organizations, various special function registers, PSW, SFRs , counters & timers, interrupts in 8051, Serial communication of 8051, I/O ports of 8051,

2. Instruction set of 8051 micro controller

Need for an instruction set, instruction format of 8051,opcode, operand, machine cycle and T-state,major groups in the instruction set, various addressing modes of 8051, data transfer, arithmetic, logical, branching and boolean instructions, one byte, two byte and three byte

instructions, , unconditional and conditional jump instructions, CALL and RET instructions, NOP instruction

3. 8051 Programming Concepts

Various symbols used in drawing flow charts, programs in mnemonics to illustrate the application of data copy instructions, programs to perform single byte, double byte and multi byte addition and subtraction, the application of jump instruction in the program, program using delay subroutines, subroutine and its use, PUSH, POP instructions, single step and break point debugging techniques.

4. Interfacing Simple I/O devices

Interfacing of push button switches and LEDs, Seven segment display interface, functions of pins of LCD, Interfacing 16x2 LCD to 8051, Program LCD in assembly language, Interfacing of a 4x4 Matrix Key Board, key bouncing problem and de-bouncing solutions

5. Programming using Embedded C

Introduction to Embedded C, Compare C and Embedded C, Data types, Embedded C Programs

REFERENCE BOOKS:

1. Mazidi and Mazidi, The 8051 Microcontroller and Embedded Systems Using Assembly and C, 2nd edition Pearson
2. Kenneth J.Ayala, 8051 Microcontroller
3. MykePredko , Programming customizing the 8051 Microcontroller, TMH
4. Ajay V Deshmukh , Microcontrollers (theory and applications)
5. Subratha Ghosal, 8051 Microcontroller (Instruction, programme & interfacing), PEARSON
6. Kenneth Ayalla, The 8051 Microcontroller, 3rd Edition, CENGAGE learning India Edition
7. Dr. Rajiv Kapadia, 8051 Microcontroller Embedded systems, Jico student Edition

BLUE PRINT

SI No	Unit Title	No of Periods	Weightage Allotted	Weightage of Marks		COs mapped
				No of Essay Questions	No of Short answer Questions	
1	Architecture of Microcontroller 8051	20	26	2	2	CO1
2	Instruction set of 8051 micro controller	15	26	2	2	CO2
3	8051 Programming Concepts	15	26	2	2	CO3
4	Interfacing Simple I/O devices	15	16	1	2	CO4
5	Programming in Embedded C	10	16	1	2	CO5
		75	110	80	30	

Table specifying the scope of syllabus to be covered for Unit Tests

Unit Test	Learning outcomes to be covered
Unit Test-I	From 1.1 to 2.16
Unit Test-II	From 3.1 to 5.14

State Board of Technical Education and Training, A. P
Diploma in Electronics and Communication Engineering (DECE)
IV Semester
Subject Name: Microcontrollers And Interfacing
Sub Code: EC - 402

Time : 90 minutes

Unit Test I

Max.Marks:40

Part-A

16Marks

Instructions: (1) Answer **all** questions.
(2) First question carries **four** marks, each question of remaining carries **three** marks

1. Write the importance of following registers in one sentence
 - a) Stack pointer (CO1)
 - b) Program counter (CO1)
 - c) Accumulator (CO1)
 - d) PSW (CO1)
2. List any three featured of microcontrollers (CO1)
3. Distinguish between machine cycle and T-state (CO2)
4. List any three data transfer instructions of 8051 microcontroller. (CO2)
5. Explain the status of flag register after executing the following two instructions. (CO2)
MOV A, #42H
ADD A, #44H

Part-B

3×8=24

Instructions: (1) Answer **all** questions.
(2) Each question carries **eight** marks
(3) Answer should be comprehensive and the criterion for valuation is the content but not the length of the answer.

6. (a) Draw the functional block diagram of 8051 microcontroller and explain about each block (CO1)
or
(b) Draw the PIN diagram of 8051 microcontroller and explain the function of each PIN (CO1)
7. (a) Explain the internal memory organization of 8051 with suitable diagram (CO1)
or
(b) Explain the SFRs associated with timer/counters of 8051 microcontroller. (CO1)
8. (a) Explain the operation carried out on execution of the following instructions. (CO2)
(i) MUL AB (ii) DIV AB (iii) DA A (iv) ADDC A, @R0
or
(b) Explain various addressing modes of 8051 microcontroller with suitable examples. (CO2)

-o0o-

(Model Paper)

C -23, EC -402

State Board of Technical Education and Training, A. P
Diploma in Electronics and Communication Engineering (DECE)

IV Semester

Subject Name: Microcontrollers And Applications

Sub Code: EC - 402

Time : 90 minutes

Unit Test II

Max.Marks:40

Part-A

16Marks

Instructions: (1) Answer **all** questions.
(2) First question carries **four** marks, each question of remaining carries **three** marks

1. Draw symbols used in flow charts to indicate the following
 - a) End or Beginning (CO3)
 - b) Process (CO3)
 - c) Decision (CO3)
 - d) Input and Output (CO3)
2. Draw the interfacing diagram of push button switch and LED with 8051. (CO4)
3. List the reasons for the popularity of LCDs (CO4)
4. List the differences between C and Embedded C (CO5)
5. List the reasons for writing programs in Embedded C (CO5)

Part-B

3×8=24

Instructions: (1) Answer **all** questions.
(2) Each question carries **eight** marks
(3) Answer should be comprehensive and the criterion for valuation is the content but not the length of the answer.

6. (a) Write an assembly language to generate a Square wave of 1 KHz from the P1.0 pin of 8051, using Timer-1 mode-1. Assume Clock Frequency of 12 MHz. (CO3)
(or)
(b) Write an assembly language to add a series of 10 bytes. The series begins from location 2000H in External RAM. Store the result at locations 3000 and 3001H. (CO3)
7. (a) Explain the Interfacing concepts of push button switches and LEDs with 8051 (CO4)
(or)
(b) Explain Interfacing of 16×2 LCD module to 8051 (CO4)
8. (a) Write an 8051 C program to send values 00 – FF to port P1 (CO5)
(or)
(b) Write an 8051 C program to toggle bits of P1 ports continuously with 250 ms (CO5)

-o0o-

MODEL PAPER

BOARD DIPLOMA EXAMINATIONS
C-23, EC-402, MICROCONTROLLERS AND APPLICATIONS
IV SEMESTER
SEMESTER END EXAMINATION

TIME:3 HOURS

MAX MARKS:80

Part-A

10×3=30

Instructions: (1) Answer **all** questions.
(2) Each question carries **three** marks
(3) Answer should be brief and straight to the point and shall not exceed five simple sentences.

1. List any three features of microcontrollers (CO1)
2. List the interrupts of 8051 (CO1)
3. List any three data transfer instructions of 8051 microcontroller. (CO2)
4. Mention the instruction format of 8051 (CO2)
5. Define a subroutine and state its use (CO3)
6. Explain PUSH and POP instructions. (CO3)
7. List the reasons for the popularity of LCDs (CO4)
8. Draw the interfacing diagram of push button switch and LED with 8051. (CO4)
9. List the differences between C and Embedded C (CO5)
10. List the reasons for writing programs in Embedded C (CO5)

Part-B

5×10=50

Instructions: (1) Answer **any five** questions.
(2) Each question carries **10** marks
(3) Answer should be comprehensive and the criterion for valuation is the content but not the length of the answer.

11. Draw the functional block diagram of 8051 microcontroller and explain about each block (CO1)
12. Explain the internal memory organization of 8051 with suitable diagram (CO1)
13. Explain the operation carried out on execution of the following instructions. (CO2)
(i) MUL AB (ii) DIV AB (iii) DA A (iv) ADDC A, @R0
14. Explain various addressing modes of 8051 microcontroller with suitable examples (CO2)
15. Write an assembly language to generate a Square wave of 1 KHz from the P1.0 pin of

- 8051, using Timer-1 mode-1. Assume Clock Frequency of 12 MHz. (CO3)
16. Write an assembly language to add a series of 10 bytes. The series begins from location 2000H in External RAM. Store the result at locations 3000 and 3001H. (CO3)
17. Explain the Interfacing concepts of push button switches and LEDs with 8051 (CO4)
18. Write an 8051 C program to toggle bits of P1 ports continuously with 250 ms (CO5)

-o0o-

Course Code	Course title	No of periods/week	Total no of periods	Marks for FA	Marks for SA
EC-403	MICROWAVE & SATELLITE COMMUNICATION SYSTEMS	05	75	20	80

S No	Unit Title	No. of Periods	COs Mapped
1	Transmission Lines and Wave Propagation	17	CO1
2	Antennas	16	CO2
3	Microwave Components and Devices	20	CO3
4	RADARs	12	CO4
5	Satellite Communication System	10	CO5
	Total	75	

Course Objectives	1. To familiarize the concepts of Microwave Engineering, Radar and Satellite communication systems.
	2. To equip with various issues related to Microwave Engineering, Radar and Satellite communication systems.
	3. To learn the practical importance and applications of Microwave Engineering, Radar and Satellite communication systems.

CO No	COURSE OUTCOMES	
CO1	EC-403.1	Describe the transmission Lines and wave propagation.
CO2	EC-403.2	Interpret the Radiation patterns of various Antennas.
CO3	EC-403.3	Analyse various microwave components and devices.
CO4	EC-403.4	Analyse the Radar Engineering.
CO5	EC-403.5	Describe the principles of Satellite communication.

CO-PO/PSO MATRIX

CO No	PO1	PO2	PO3	PO4	PO5	PO6	PO7	PSO1	PSO2	PSO3
EC-403.1	3				1			3		1
EC-403.2	3	2	1		2			3	1	
EC-403.3	3	1	1		1			3		1
EC-403.4	3	3	2	1	2			3		2
EC-403.5	3	3	1	2	3		1	3	1	2
Average	3	1.8	1.25	1.5	1.8			3	1	1.5

3=strongly mapped 2=moderately mapped 1=slightly mapped

LEARNING OUTCOMES

1.0 Transmission lines and wave propagation

- 1.1 Introduction to transmission lines and different types.
- 1.2 Draw the electrical equivalent of transmission line.
- 1.3 Define the primary and secondary constants of a transmission line.
- 1.4 Explain the significance of characteristic impedance and Propagation constant of a transmission line.
- 1.5 Define reflection coefficient and standing wave ratio and give the relation between them.
- 1.6 Explain the concept of Reflection, Refraction and diffraction of EM waves.
- 1.7 Explain the Ground wave propagation with the equation for electric field at a distant place.
- 1.8 List the applications and limitations of ground wave propagation
- 1.9 Classify different layers of ionosphere and briefly explain them
- 1.10 Explain the ionospheric wave (sky wave) propagation
- 1.11 Define the terms
 - i) Critical Frequency ii) MUF iii) Skip Distance iv) Skip Zone v) Actual height and vi) Virtual height of an Ionosphere
- 1.12 Explain Space wave (tropospheric wave) propagation and factors affecting space wave propagation (LOS)
- 1.13 Briefly explain i) Duct propagation & ii) Tropospheric Scatter Propagation

2.0 Antennas

- 2.1 Explain the principle of radiation of EM waves from antennas
- 2.2 Explain radiation mechanism of an antenna from transmission line theory
- 2.3 State the following parameters of antenna
 - i. Radiation pattern
 - ii. Front to back ratio
 - iii. Directive gain
 - iv. Directivity
 - v. Power gain
 - vi. Beamwidth
 - vii. Bandwidth
 - viii. Antenna resistance: Radiation and Loss Resistance
 - ix. Antenna efficiency
 - x. Antenna aperture (Effective area)
 - xi. Antenna polarization
- 2.4 Explain Isotropic radiator
- 2.5 Classify antennas based on i) Radiation pattern ii) Frequency range iii) Construction iv) Bandwidth
- 2.6 Explain the function of dipole and folded dipole antennas and give their applications
- 2.7 List different microwave antennas
- 2.8 Explain different horn antennas and give its applications
- 2.9 Explain the construction and working principle of Parabolic Dish antenna
- 2.10 State the need of antenna arrays
- 2.11 Explain about end-fire array and broadside array
- 2.12 Introduction to smart antennas

- 2.13 Working of smart antennas
- 2.14 Main types of smart antennas (Switched beam and Adaptive array)
- 2.15 Applications and Advantages of smart antennas.

3.0. Microwave Components and Devices

- 3.1 Define microwave frequencies
- 3.2 State the different microwave frequency bands and their applications
- 3.3 State the function of waveguides and classify them
- 3.4 Explain the concept of propagation of wave in rectangular waveguides
- 3.5 Define TE (Transverse Electric) Mode and TM (Transverse Magnetic) Mode
- 3.6 Define the terms: i) dominant mode, ii) cut-off wavelength, iii) cut-off frequency iv) phase velocity and v) group velocity related to waveguides
- 3.7 List different Microwave passive devices
- 3.8 State the uses of i) T-junctions: E-Plane T, H-Plane T & Hybrid T ii) Microwave Bends iii) Microwave tapers iv) Microwave Twist
- 3.9 Explain the working principle of Reflex Klystron
- 3.10 Explain the working principle of Magnetron and state its applications
- 3.11 Explain the working principle of Travelling Wave Tube and state its applications
- 3.12 List different microwave solid state devices
- 3.13 Explain the working of Gunn diode
- 3.14 Explain the working IMPATT DIODE

4.0 RADARs

- 4.1 State the basic working principle of a RADAR
- 4.2 Derive the free space RADAR range equation
- 4.3 Explain the factors affecting range of a RADAR
- 4.4 Classify RADARs
- 4.5 Draw the block diagram of a pulse RADAR and explain the function of each block
- 4.6 State the major advantages & disadvantages of a pulsed RADAR system
- 4.7 State the need of duplexer
- 4.8 List the various displays used in RADAR
- 4.9 Draw and explain the block diagram of continuous wave (CW) RADAR
- 4.10 Explain the Doppler Effect
- 4.11 Draw and explain the moving target indicating (MTI) RADAR
- 4.12 Briefly explain the concept of blind speed
- 4.13 List the applications of RADARs

5.0 Satellite Communication System

- 5.1 State the need for satellite communication
- 5.2 List the advantages of satellite communication system over terrestrial communication system
- 5.3 Explain uplink and down link frequencies
- 5.4 List various types of satellites (LEOs, MEOs and GEOs)
- 5.5 List the advantages of Geosynchronous satellites
- 5.6 Draw and explain block diagram of a satellite communication system (Satellite on board)
- 5.7 Draw the block diagram of earth station and explain each block.
- 5.8 List the functions of the satellite transponder.
- 5.9 Explain various types of transponders used in satellite.

- 5.10 Explain the bandwidth of satellite system.
- 5.11 Explain the application of satellite in GPS (Global Position System).
- 5.12 Explain the application of satellite in Direct to Home (DTH) TV.

COURSE CONTENTS:

1 Transmission lines and Wave Propagation

Transmission lines-Primary and Secondary constants-reflection coefficient-standing wave ratio- Effects of environment-Ground wave propagation -Applications, limitations - layers of ionosphere - sky wave propagation- Actual height, Virtual height, Critical frequency - Maximum usable frequency- Skip distance, Skip zone (dead zone)-Space wave (tropospheric wave) propagation-Duct propagation & ii) Tropospheric scattering

2 Antennas

Radiation of EM waves from antennas- Isotropic radiator - Classify antennas - Antenna Parameters - dipole and folded dipole antennas- different microwave antennas- Horn antenna - Parabolic reflector – end fire array and Broadside array-smart antennas

3 Microwave Components and Devices

Microwave frequencies - Rectangular wave guides - TE (Transverse Electric) Mode and TM (Transverse Magnetic) Mode- T-junctions - Microwave Bends - Microwave tapers- Reflex Klystron - Magnetron- Travelling Wave Tube- microwave solid state devices - Gunn diode - IMPATT diode.

4 RADARS

Working principle of a RADAR- Radar Range Equation- Pulse Radar -need of duplexer –displays of RADAR-Continuous Wave (CW) Radar- Doppler Effect - Moving Target Indicating (MTI) Radar – blind speed – Applications of RADARS

5 Satellite Communication Systems

Block diagram of a satellite communications system- Advantages - block diagram of earth station-satellite transponders –bandwidth of satellite-application of satellite in GPS (Global Position System), Direct to Home (DTH) TV.

Reference Books:

1. F.E.Terman, Electronic and Radio engineering, McGraw Hill Publishers
2. George F Kenndy, Electronic communication system, McGraw Hill Publishers
3. AthanasiosG.Kanatas, AthanasiosD.Panagopopulos, Radio Wave Propagation and channel modeling for earth-space systems, CRC Press
4. UmeshSinha, Networks and Transmission lines, Satya Prakashan, Tech India Publications, New Delhi, 2001.
5. Ian A. Glover, Steve pennock, Microwave Devices, circuits and subsystems for Communication engineering, Wiley-Blackwell Publishers

6. Samuel Y. Liao, Microwave Devices and Circuits, Pearson Publishers
7. G.S.N. Raju, Microwave devices, I K International Publishing House Pvt. Ltd
8. E.V.D. Glazier and H.R.L. Lamont, Transmission and Propagation, The Services Text Book of Radio, vol. 5, Standard Publishers Distributors, Delhi.
9. K D Prasad, Antenna Theory, SatyaPrakashan, Tech India Publications, New Delhi, 2001.
10. A.V. Bakshi, Transmission line and waveguides, Technical Publications, 2009
11. MojjitMitra, Satellite communication, PHI
12. Michael O Kolawole, Satellite communication Engineering, CRC Press

BLUE PRINT:

SI No	Unit Title	No of Periods	Weightage Allotted	Weightage of Marks		COs mapped
				No of Essay Questions	No of Short answer Questions	
1	Transmission lines and Wave Propagation	15	21	1.5	2	CO1
2	Antennas	12	16	1.5	2	CO2
3	Microwave Components and Devices	20	26	2	2	CO3
4	RADARs	18	26	2	2	CO4
5	Satellite Communication System	10	16	1	2	CO5
		75	110	80	30	

Table specifying the scope of syllabus to be covered for Unit Tests

Unit Test	Learning outcomes to be covered
Unit Test-I	From 1.1 to 2.16
Unit Test-II	From 3.1 to 5.14

(Model Paper)

C –23, EC -403

State Board of Technical Education and Training, A. P
Diploma in Electronics and Communication Engineering (DECE)

IV Semester

Subject Name: **Microwave & Satellite Communication Systems**

Sub Code: **EC - 403**

Part-A

16Marks

Instructions: (1) Answer **all** questions.
 (2) First question carries **four** marks, each question of remaining carries **three** marks

1. Fill the following blanks with one word
 - a) Critical frequency is the highest magnitude of frequency above which the waves penetrate the ionosphere and below which the waves are reflected back from the ionosphere (State True/False) (CO 1)
 - b) Ionosphere propagation is also called as tropospheric propagation (State True/False) (CO 1)
 - c) Maximum directivity of an antenna is indicated with which term _____ (CO 2)
 - d) The radiation pattern of end fire array is bi directional (State True/False) (CO 2)
2. Classify the layers of Ionosphere (CO 1)
3. Describe briefly about tropospheric scattering (CO 1)
4. State the parameters of antenna (CO 2)
5. State the need of antenna arrays (CO 2)

Part-B

3×8=24

Instructions: (1) Answer **all** questions.
 (2) Each question carries **eight** marks
 (3) Answer should be comprehensive and the criterion for valuation is the content but not the length of the answer.

6. (a) Explain the Ground wave propagation and ground effects on EM waves (CO1)
 or
 (b) Explain Space wave propagation and factors affecting space wave propagation (CO1)
7. (a) Explain Horn antenna and give its applications (CO2)
 or
 (b) Explain the concepts of: i) Skip distance & ii) Skip zone (dead zone) (CO2)
8. (a) Explain energy absorption and wave path in the ionosphere (CO1)
 or
 (b) Explain the working principle of Travelling Wave Tube and state its applications (CO2)

-oOo-

(Model Paper)

C –23, EC -403

State Board of Technical Education and Training, A. P
 Diploma in Electronics and Communication Engineering (DECE)

IV Semester

Subject Name: **Microwave & Satellite Communication Systems**Sub Code: **EC - 403**

Part-A

16Marks

- Instructions:** (1) Answer **all** questions.
(2) First question carries **four** marks, each question of remaining carries **three** marks

1. Fill the following blanks with one word
 - a) Write any one microwave passive device (CO3)
 - b) In radar and radio communications systems, duplexer isolates the receiver from the transmitter while permitting them to share a common antenna (**State True/False**) (CO 4)
 - c) Write the full form of DTH (CO5)
 - d) Write the full form of GPS (CO5)
2. Describe various modes of operations of wave guides (CO3)
3. Classify different types of waveguides (CO3)
4. State the factors affecting range of a RADAR (CO4)
5. Interpret the advantages of satellite communication system over terrestrial communication systems (CO5)

Part-B

3×8=24

- Instructions:** (1) Answer **all** questions.
(2) Each question carries **eight** marks
(3) Answer should be comprehensive and the criterion for valuation is the content but not the length of the answer.

6. (a) Explain the working principle of Magnetron and state its applications (CO3)
or
(b) Explain the working principle of Travelling Wave Tube and state its applications (CO3)
7. (a) Draw and explain the block diagram of Continuous Wave(CW) RADAR (CO4)
or
(b) Draw and explain the Moving Target Indicator (MTI) RADAR (CO4)
8. (a) Draw and explain block diagram of a satellite communications system (CO5)
or
(b) Explain the application of satellite in GPS (Global Position System) (CO5)

-oOo-

MODEL PAPER
BOARD DIPLOMA EXAMINATIONS
C-23, EC-403, MICROWAVE & SATELLITE COMMUNICATION SYSTEMS
IV SEMESTER
SEMESTER END EXAMINATION

TIME: 3 HOURS

MAX MARKS:80

Part-A

10×3=30

Instructions: (1) Answer **all** questions.
(2) Each question carries **three** marks
(3) Answer should be brief and straight to the point and shall not exceed five simple sentences.

1. Define critical frequency and maximum usable frequency (CO1)
2. Classify the layers of Ionosphere (CO1)
3. Define beamwidth and bandwidth of an antenna (CO2)
4. State the need for antenna arrays (CO2)
5. Define dominant mode and cut-off wavelength of a waveguide (CO3)
6. Write the function of Microwave Twist and Taper (CO3)
7. Write the need for Duplexer in Pulsed RADAR (CO4)
8. Define Blind Speed (CO4)
9. List the advantages of satellite communication system over terrestrial communication systems (CO5)
10. Write functions of Satellite Transponder (CO5)

Part-B

5×10=50

Instructions: (1) Answer **any Five** questions.
(2) Each question carries **TEN** marks
(3) Answer should be comprehensive and the criterion for valuation is the content but not the length of the answer.

11. Explain Space wave propagation and factors affecting space wave propagation (CO1)

12. Explain the working principle of microwave dish antenna (CO2)
13. Explain the working principle of GUNN diode and state its applications (CO3)
14. Explain the working principle of Travelling Wave Tube amplifier (CO3)
15. Draw and explain the block diagram of Continuous Wave (CW) RADAR (CO4)
16. Draw and explain the Moving Target Indicator (MTI) RADAR (CO4)
17. Draw and explain block diagram of a satellite communications system (CO5)
18. a) Derive the relation between reflection coefficient and SWR (5 Marks) (CO2)
 b) Write short notes on smart antennas (5 Marks) (CO2)

-o0o-

IoT and SENSORS

Course Code	Course title	No of periods/week	Total no of periods	Marks for FA	Marks for SA
EC-404	IoT AND SENSORS	04	60	20	80

S No	Unit Title	No. of Periods	COs Mapped
1	Introduction to Industry 4.0 and Internet of Things	12	CO1
2	Elements of IoT	10	CO2
3	Sensors and Actuators	10	CO3
4	Connectivity Technologies, computing hardware and Software components	13	CO4
5	IoT Case Studies	15	CO5
	Total	60	

Course Objectives	To Introduce Industry 4.0 and Internet of Things
	To familiarise with Sensors and Actuators in connection with IoT
	To familiarise with Connectivity Technologies, computing hardware and Software components in connection with IoT and to explore case case studies

CO No		COURSE OUTCOMES
CO1	EC-404.1	Introduce Industry 4.0 and Internet of Things
CO2	EC-404.2	Get acquient with Elements of IoT
CO3	EC-404.3	Get acquient with Sensors and Actuators in connection with IoT
CO4	EC-404.4	Understand connectivity Technologies, computing hardware and Software components in connection with IoT
CO5	EC-404.5	Explore IoT Case Studies

CO-PO/PSO MATRIX

CO No	PO1	PO2	PO3	PO4	PO5	PO6	PO7	PSO1	PSO2	PSO3
EC-403.1	3				1			3		1
EC-403.2	3	2	1		2			3	1	
EC-403.3	3	1	1		1			3		1

EC-403.4	3	3	2	1	2			3		2
EC-403.5	3	3	1	2	3		1	3	1	2
Average	3	1.8	1.25	1.5	1.8			3	1	1.5

3=strongly mapped
2=moderately mapped
1=slightly mapped

LEARNING OUTCOMES

1.0 Introduction to Industry 4.0 and Internet of Things

- 1.1 Explain the concept of Industry 4.0 and its benefits.
- 1.2 Explain the components of futuristic industrial plant in industry 4.0 with a block diagram
- 1.3 Define IoT and state its role in Industry 4.0
- 1.4 List the goals of industry 4.0
- 1.5 List the advantages of industry 4.0
- 1.6 Explain what technologies driving industry 4.0
- 1.7 Explain various challenges in industry 4.0
- 1.8 State the impact of IoT on businesses and society
- 1.9 List the applications of IoT in different industries.
- 1.10 Explain the concepts of different IoT enabling Technologies such as: i) Wireless Sensor networks ii) Cloud Computing iii) Big Data Analytics iv) Communication Protocols iv) Embedded Systems
- 1.11 Explain the concepts of different IoT Levels (IoT Level-1 to Level-5) and Development Templates
- 1.12 Explain M2M and IoT Technology Fundamentals such as: i) Devices and Gateways ii) Data Management iii) Business Process in IoT iv) Everything as a Service (XaaS)
- 1.13 State the role of cloud in IoT
- 1.14 State the Security aspects of IoT

2.0 Elements of IoT

- 2.1 State the elements of IoT such as: i) Sensors & Actuators ii) Edge Gateway iii) Communication Protocols iv) computing hardware v) Software components and their use
- 2.2 Classify sensors used in IoT based on i) Passive & Active ii) Analog & digital iii) Scalar & vector and give examples
- 2.3 List the common actuators used in IoT
- 2.4 State the role of edge gateway in IoT
- 2.5 State the function of computing hardware in IoT
- 2.6 State the purpose of communication protocols used in IoT
- 2.7 List different communication protocols used in IoT
- 2.8 List different software components used in IoT
- 2.9 Explain the functions of Sensors & actuators in IoT
- 2.10 Explain the function of software components in data storage and data analytics in IoT

3.0 Sensors and Actuators

- 3.1 List the common analog sensors used in IoT
- 3.2 List the common digital sensors used in IoT
- 3.3 State the functions and applications the following sensors :i)Temperature sensors ii) Pressure sensors ii) Motion sensors iii) Level sensors iv) Image sensors v) Proximity sensors vi) Water quality sensors vii) Chemical sensors viii) Gas sensors viii) Smoke sensors ix) Infrared (IR) sensors x) Acceleration sensors xi) Gyroscopic sensors xii) Humidity sensors xiii) Optical sensors
- 3.4 State the specifications of DHT11 temperature and humidity sensor module For Arduino Raspberry Pi
- 3.5 State the specifications of BMP280 Pressure Sensor Module High Precision Arduino
- 3.6 State the specifications of MQ-2 Smoke/Gas Sensor Module for Arduino
- 3.7 State the specifications of HC-SR501 Adjust Ir Pyroelectric Infrared PIR Motion Sensor Module for Arduino, ARM
- 3.8 State the function of the following actuators : i) Hydraulic Actuators ii) Pneumatic Actuators iii) Electrical Actuators iv) Thermal/Magnetic actuators iv) Mechanical actuators

4.0 Connectivity Technologies, computing hardware and Software components

- 4.1. State the use of Standard Wireless Access connecting technologies such as i) WiFi ii) 2G, 3G and standard LTE, 5G in IoT
- 4.2. State the use of Private Long Range – LoRA based platform, Zigbee, and SigFox.
- 4.3. State the use of Mobile IoT Technologies – LTE-M, NB-IoT, and EC-GSM-IoT
- 4.4. State the specifications (coverage range, data rate) and IoT specific applications of the following connecting technologies: i) WiFi ii) 2G iii) 3G iv) 4G v) 5G vi) LoRA based platform vii) Zigbee viii) SigFox
- 4.5. What is NFC (Near Field Communication) and List its applications
- 4.6. Differences between NFC and Bluetooth and WiFi technologies
- 4.7. List the typical specifications and applications of i) WiFi ii) Bluetooth iii) Zigbee iv) GSM v) GPS modules designed for Arduino, Raspberry Pi hardware platforms
- 4.8. Explain the use of Computing Hardware (Arduino, Raspberry Pi) in IoT

5.0 IoT Case Studies

- 5.1 Explain the IoT based system for Home Automation with block diagram
- 5.2 Explain the IoT based system for Smart lighting with block diagram
- 5.3 Explain the IoT based system for Home intrusion detection with block diagram
- 5.4 Explain the IoT based system for Air pollution monitoring system with block diagram
- 5.5 Explain the IoT based system for Smart irrigation with block diagram
- 5.6 Explain the IoT based system for Healthcare with block diagram

COURSE CONTENT:

1. Introduction to Industry 4.0 and Internet of Things

Concept of Industry 4.0 and its benefits- components of futuristic industrial plant in industry 4.0- Define IoT and state its role in Industry 4.0-List the goals of industry 4.0- advantages of industry 4.0- technologies driving industry 4.0-various challenges in industry 4.0- the impact of IoT on businesses and society- applications of IoT in different industries- the concepts of different IoT enabling Technologies - M2M and IoT Technology Fundamentals -role of cloud in IoT - the Security aspects of IoT

2. Elements of IoT

Elements of IoT --classify sensors used in IoT - common actuators used in IoT- the role of edge gateway in IoT- the function of computing hardware in IoT-the purpose of communication protocols used in IoT- different communication protocols used in IoT- different software components used in IoT- the functions of Sensors & actuators in IoT- the function of software components in data storage and data analytics in IoT-sensors and Actuators-Connectivity Technologies, computing hardware and Software components

3. Sensors and Actuators

List the common analog sensors used in IoT -List the common digital sensors used in IoT-State the function the following sensors :i)Temperature sensors ii) Pressure sensors ii) Motion sensors iii) Level sensors iv) Image sensors v) Proximity sensors vi) Water quality sensors vii) Chemical sensors viii) Gas sensors viii) Smoke sensors ix) Infrared (IR) sensors x) Acceleration sensors xi) Gyroscopic sensors xii) Humidity sensors xiii) Optical sensors-State the specifications of DHT11 temperature and humidity sensor module For Arduino Raspberry Pi-State the specifications of BMP280 Pressure Sensor Module High Precision Arduino-State the specifications of MQ-2 Smoke/Gas Sensor Module for Arduino-State the specifications of HC-SR501 Adjust Ir Pyroelectric Infrared PIR Motion Sensor Module for Arduino, ARM -State the function of the following actuators : i) Hydraulic Actuators ii) Pneumatic Actuators iii) Electrical Actuators iv) Thermal/Magnetic actuators iv) Mechanical actuators

4.Connectivity Technologies, computing hardware and Software components

State the use of Standard Wireless Access connecting technologies such as i) WiFi ii) 2G, 3G and standard LTE, 5G in IoT-State the use of Private Long Range – LoRA based platform, Zigbee, and SigFox. -State the use of Mobile IoT Technologies – LTE-M, NB-IoT, and EC-GSM-IoT-State the specifications (coverage range, data rate) and IoT specific applications of the following connecting technologies: i) WiFi ii) 2G iii) 3G iv) 4G v) 5G vi) LoRA based platform vii) Zigbee viii) SigFox-What is NFC (Near Field Communication) and List its applications-Differences between NFC and Bluetooth and WiFi technologies-List the typical specifications and applications of i) WiFi ii) Bluetooth iii) Zigbee iv) GSM v) GPS modules designed for Arduino, Raspberry Pi hardware platforms-Explain the use of Computing Hardware (Arduino, Raspberry Pi) in IoT

5. IoT Case Studies

Explain the following IoT Case Studies with block diagrams -i) Home Automation-ii)Smart lighting - iii)Home intrusion detection -iv) Air pollution monitoring system -v) Smart irrigation -vi)Healthcare

Reference Books:

1. Vijay Madiseti, Arshdeep Bahga, Internet of Things, "A Hands on Approach", University Press
2. Dr. SRN Reddy, Rachit Thukral and Manasi Mishra, "Introduction to Internet of Things: A practical Approach", ETI Labs
3. Pethuru Raj and Anupama C. Raman, "The Internet of Things: Enabling Technologies, Platforms, and Use Cases", CRC Press
4. Jeeva Jose, "Internet of Things", Khanna Publishing House, Delhi
5. Adrian McEwen, "Designing the Internet of Things", Wiley
6. Raj Kamal, "Internet of Things: Architecture and Design", McGraw Hill
7. Cuno Pfister, "Getting Started with the Internet of Things", O Reilly Medi
8. Internet of Things Reference Architecture – Whitepaper – CISCO
9. IoT and Edge Computing for Architects: Implementing edge and IoT systems from sensors to clouds with communication systems, analytics, and security, 2nd Edition – Perry Lea, Packt Publishing Limited, ISBN-10: 189214805
10. IoT Fundamentals: Networking Technologies, Protocols and Use Cases for Internet of Things, David Hanes, Gonzalo Salgueiro, Patrick Grossetete, Rob Barton and Jerome Henry, Cisco Press, 2017
11. The Internet of Things – Key applications and Protocols, Olivier Hersent, David Boswarthick, Omar Elloumi and Wiley, 2012 (for Unit 2).
12. "From Machine-to-Machine to the Internet of Things – Introduction to a New Age of Intelligence", Jan Höller, Vlasios Tsiatsis, Catherine Mulligan, Stamatis, Karnouskos, Stefan Avesand. David Boyle and Elsevier, 2014.
13. Architecting the Internet of Things, Dieter Uckelmann, Mark Harrison, Michahelles and Florian (Eds), Springer, 2011

BLUE PRINT:

SI No	Unit Title	No of Periods	Weightage Allotted	Weightage of Marks		COs mapped
				No of Essay Questions	No of Short answer Questions	
1	Introduction to Industry 4.0 and Internet of Things	12	26	2	2	CO1
2	Elements of IoT	10	16	1	2	CO2
3	Sensors and Actuators	10	16	1	2	CO3
4	Connectivity Technologies, computing	13	26	2	2	CO4

	hardware and Software components					
5	IoT Case Studies	15	26	2	2	CO5
		75	110	80	30	

Table specifying the scope of syllabus to be covered for Unit Tests

Unit Test	Learning outcomes to be covered
Unit Test-I	From 1.1 to 3.5
Unit Test-II	From 3.6 to 5.6

(Model Paper)

C –23, EC -404

State Board of Technical Education and Training, A. P
Diploma in Electronics and Communication Engineering (DECE)

IV Semester

Subject Name: **IoT and Sensors**

Sub Code: **EC - 404**

Time: 90 minutes

Unit Test I

Max.Marks:40

Part-A

16Marks

Instructions: (1) Answer **all** questions.
(2) First question carries **four** marks, each question of remaining carries **three** marks

1. Fill the following blanks with one word
 - a) IoT stand for _____ (CO 1)
 - b) XaaS stands for _____ (CO 1)
 - c) Sensor in IoT is for _____ purpose (CO 2)
 - d) Actuator in IoT is for _____ purpose (CO 2)
2. List the goals of industry 4.0 (CO 1)
3. State the role of edge gateway in IoT (CO 2)
4. List the common analog sensors used in IoT (CO 3)
5. State the role of cloud in IoT (CO 1)

Part-B

3×8=24

Instructions: (1) Answer **all** questions.
 (2) Each question carries **eight** marks
 (3) Answer should be comprehensive and the criterion for valuation is the content but not the length of the answer.

6. (a) Explain the components of futuristic industrial plant in industry 4.0 with a block diagram (CO1)
 Or
 (b) Explain the concepts of different IoT Levels and Development Templates (CO1)
7. (a) Classify sensors used in IoT based on i) Passive & Active ii) Analog & digital iii) Scalar & vector and give examples (CO2)
 or
 (b) 2.0 Explain the functions of Sensors & actuators in IoT (CO2)
8. (a) State the function the following sensors :i)Temperature sensors ii) Pressure sensors ii) Motion sensors iii) Level sensors iv) Image sensors (CO3)
 or
 (b) State the specifications of i) DHT11 temperature and humidity sensor module ii)State the specifications of BMP280 Pressure Sensor Module (CO3)
 -o0o-

(Model Paper)

C –23, EC -404

State Board of Technical Education and Training, A. P
 Diploma in Electronics and Communication Engineering (DECE)

IV Semester

Subject Name: **IoT and Sensors**

Sub Code: **EC - 404**

Time: 90 minutes

Unit Test II

Max.Marks:40

Part-A

16Marks

Instructions: (1) Answer **all** questions.
 (2) First question carries **four** marks, each question of remaining carries **three** marks

1. Fill the following blanks with one word
 - a) HC-SR501 is a _____ sensor (CO 3)
 - b) NFC stands for _____ (CO 4)
 - c) _____ is an example for Computing Hardware used in IoT (CO 4)
 - d) _____ is a sensor used in IoT based Home automations (CO 5)
2. List any three Standard Wireless Access connecting technologies used in IoT (CO 4)
3. What is NFC (Near Field Communication) and List its applications (CO 4)
4. List any three sensors used in IoT based system for Smart lighting (CO 5)
5. List any two actuators used in IoT based system for Smart irrigation (CO 5)

Part-B

3×8=24

Instructions: (1) Answer **all** questions.

(2) Each question carries **eight** marks

(3) Answer should be comprehensive and the criterion for valuation is the content but not the length of the answer.

6. (a) State the function of the following actuators : i) Hydraulic Actuators ii) Pneumatic Actuators (CO3)
 or
 (b) State the function of the following actuators : i) Electrical Actuators ii) hermal/Magnetic actuators (CO3)
7. (a) State the use of Standard Wireless Access connecting technologies such as i) WiFi ii) 2G, 3G and standard LTE, 5G in IoT (CO4)
 or
 (b) Differences between NFC and Bluetooth and WiFi technologies (CO4)
8. (a) Explain the IoT based system for Home Automation with block diagram (CO5)
 or
 (b) Explain the IoT based system for Smart irrigation with block diagram (CO5)

-oOo-

MODEL PAPER
BOARD DIPLOMA EXAMINATIONS
C-23, EC-404, IoT and Sensors
IV SEMESTER
SEMESTER END EXAMINATION

TIME: 3 HOURS

MAX MARKS:80

Part-A

10×3=30

Instructions: (1) Answer **all** questions.

(2) Each question carries **three** marks

(3) Answer should be brief and straight to the point and shall not exceed five simple sentences.

1. List the goals of industry 4.0 (CO1)
2. State the role of cloud in IoT (CO1)
3. State the role of edge gateway in IoT (CO2)
4. State the function of computing hardware in IoT (CO2)
5. List the common analog sensors used in IoT (CO3)
6. List the common digital sensors used in IoT (CO3)
7. List any three Standard Wireless Access connecting technologies used in IoT (CO4)
8. What is NFC (Near Field Communication) and List its applications (CO4)
9. List any three sensors used in IoT based system for Smart lighting (CO5)
10. List any two actuators used in IoT based system for Smart irrigation (CO5)

Part-B

5×10=50

Instructions: (1) Answer **any Five** questions.
 (2) Each question carries **TEN** marks
 (3) Answer should be comprehensive and the criterion for valuation is the content but not the length of the answer.

11. Explain the components of futuristic industrial plant in industry 4.0 with a block diagram (CO1)
12. Explain the concepts of different IoT Levels and Development Templates (CO1)
13. Classify sensors used in IoT based on i) Passive & Active ii) Analog & digital iii) Scalar & vector and give examples (CO2)
14. State the function the following sensors :i)Temperature sensors ii) Pressure sensors ii) Motion sensors iii) Level sensors iv) Image sensors (CO3)
15. State the use of Standard Wireless Access connecting technologies such as i) WiFi ii) 2G, 3G and standard LTE, 5G in IoT (CO4)
16. Differences between NFC and Bluetooth and WiFi technologies (CO4)
17. Explain the IoT based system for Home Automation with block diagram (CO5)
18. Explain the IoT based system for Smart irrigation with block diagram (CO5)

-o0o-

DIGITAL LOGIC DESIGN THROUGH VERILOG HDL

Course Code	Course title	No of periods/week	Total no of periods	Marks for FA	Marks for SA
EC-405	DIGITAL LOGIC DESIGN THROUGH VERILOG HDL	05	75	20	80

S No	Unit Title	No. of Periods	COs Mapped
1	Introduction to Verilog HDL, Language constructs and conventions	20	CO1
2	Gate level and Data flow modeling.	10	CO2
3	Behavioral modeling	15	CO3

4	Modeling of combinational and sequential logic circuits	15	CO4
5	System design concepts	15	CO5
Total		75	

Course Objectives	To introduce the need of hardware description languages such as Verilog HDL and to Use Verilog HDL constructs and conventions.
	To Understand the concepts of Gate level and Data flow modelling and Behavioral modeling
	To Understand modeling of combinational and sequential logic circuits

CO No		COURSE OUTCOMES
CO1	EC-405.1	Apply the basics of Hardware Description Languages and use Verilog modules, instantiation process and hierarchical modeling concepts, Use Verilog HDL constructs and conventions.
CO2	EC-405.2	Develop Simple combinational logic circuits using Gate level and Data flow modeling.
CO3	EC-405.3	Develop Simple combinational and sequential logic circuits using Behavioral modeling in Verilog HDL.
CO4	EC-405.4	Design and Simulate sequential circuits using Verilog HDL.
CO5	EC-405.5	Using concepts of Finite State machine and PLDs, FPGA, analyze system designs steps of UART and Traffic Light Controller

CO-PO/PSO MATRIX

CO No	PO1	PO2	PO3	PO4	PO5	PO6	PO7	PSO1	PSO2	PSO3
EC-403.1	3				1			3		1
EC-403.2	3	2	1		2			3	1	
EC-403.3	3	1	1		1			3		1
EC-403.4	3	3	2	1	2			3		2
EC-403.5	3	3	1	2	3		1	3	1	2
Average	3	1.8	1.25	1.5	1.8			3	1	1.5

3=strongly mapped 2=moderately mapped 1=slightly mapped

LEARNING OUTCOMES

1.0 Introduction to Verilog HDL, Language constructs and conventions

- 1.1 Explain the steps involved in the design flow for the VLSI IC design
- 1.2 Explain the importance of Hardware Description Languages in VLSI design
- 1.3 Compare VHDL and Verilog HDL
- 1.4 List the features of Verilog HDL
- 1.5 Explain the difference between an instantiation and inference of a component.
- 1.6 Explain differences between modules and module instances in Verilog.
- 1.7 Explain four levels of abstraction to represent the internals of a module

- 1.8 Identify the components of a Verilog module definition
- 1.9 Explain the port connection rules in a module instantiation
- 1.10 Explain about the hierarchical modelling/ Design methodologies
- 1.11 List the advantages of hierarchical modelling.
- 1.12 Explain the lexical conventions like number specification, Identifiers, keywords, etc.
- 1.13 Explain different data types like value set, nets, registers, vectors, integer, real and time Register data types
- 1.14 Explain data types like arrays, memories and strings.
- 1.15 Explain the difference between arrays and vectors with example
- 1.16 Explain defparam and localparam keywords
- 1.17 Explain about system tasks and compiler directives
- 1.18 Define expressions, operators and operands.
- 1.19 Explain all types of operators used in the Verilog HDL

2.0 Understand the concepts of Gate level and Data flow modeling.

- 2.1 Identify the logic gate primitives provided in Verilog
- 2.2 Explain the instantiation of gates, gate symbols, and truth tables for and/or and buf/not type gates.
- 2.3 Explain Rise, fall and turn-off delays in the gate level modeling.
- 2.4 Explain the assignment statements in data flow modeling
- 2.5 Explain different types of delays used in the data flow level modeling
- 2.6 List the advantages of data flow modeling over gate level modeling.
- 2.7 Design simple logic combinational circuits like adders and subtractors, multiplexers and demultiplexers, encoders and Decoders, comparators and ALU using Data Flow and Gate level Modeling.

3.0 Understand the concepts of Behavioral modeling

- 3.1 Explain structural procedures - initial and always statements.
- 3.2 Explain blocking and non blocking procedural assignments with examples
- 3.3 Explain timing controls like delay based timing control and event based timing control
- 3.4 Explain conditional statements.
- 3.5 Explain multiway branching – use case, caseX, and caseZ statements.
- 3.6 Explain the difference between conditional if statement and case statements.
- 3.7 Explain looping statements such as while, for, repeat, and forever.
- 3.8 Explain sequential and parallel blocks.
- 3.9 Explain about user defined primitives (UDP).
- 3.10 List the types of UDPs
- 3.11 Explain combinational UDPs with example
- 3.12 Explain sequential UDPs with example

4.0 Understand behavioral modeling of combinational and sequential logic circuits

- 4.1 Design combinational circuits like i) Multiplexers ii) Demultiplexers iii) Encoders iv) Decoders
- 4.2 Design RS, JK, T and D flip flops with Asynchronous and Synchronous Clock and reset
- 4.3 Explain implementation of shift registers like SISO, SIPO, PISO, PIPO, etc.
- 4.4 Design synchronous and asynchronous counters
- 4.5 Design a divide by 3 counter
- 4.6 Design shift register counters like ring counter, etc.
- 4.7 Design memories like RAM and ROM.
- 4.8 Compare RTL level and structural level modeling.
- 4.9 Explain the importance of stimulus block/test bench module.

- 4.10 Explain the structure of stimulus module.
- 4.11 Apply the stimulus modules for combinational and sequential circuits of Verilog designs

5.0 Understand the system design concepts

- 5.1 Explain the importance of Finite State Machines
- 5.2 Explain the Mealy and Moore types of State Machines.
- 5.3 Explain the design of Mealy state machine using Verilog HDL
- 5.4 Explain the design of Moore state machine using Verilog HDL
- 5.5 List various design tools which are useful in different stages of design.
- 5.6 List four important programmable logic devices.
- 5.7 Explain the architecture of PLAs.
- 5.8 Explain the architecture of PALs
- 5.9 Explain the architecture of CPLD.
- 5.10 Explain the architecture of FPGA.
- 5.11 Compare the programmable logic devices.
- 5.12 List any 3 applications of programmable logic devices.
- 5.13 Explain the design steps for simple systems like UART, Traffic Light controller using FPGA board

COURSE CONTENT:

1. Introduction to Verilog HDL, Language constructs and conventions

Steps involved in the design flow for the VLSI IC design-Importance of Hardware Description Languages in VLSI design-Compare VHDL and Verilog HDL-Features of Verilog HDL-Difference between an instantiation and inference of a component-Differences between modules and module instances in Verilog-Levels of abstraction to represent the internals of the module-Identify the components of a Verilog module definition-Port connection rules in module instantiation-hierarchical modeling concepts, Lexical conventions like number specification, Identifiers, Keywords, etc-Different data types like value set, nets, registers, vectors, integer, real and time register data types, arrays, memories and strings-defparam and localparam keywords-System tasks and compiler directives-Expressions, operators and operands-Types of operators used in the Verilog HDL

2. Understand the concepts of Gate level and Data Flow modeling

Logic gates primitives provided in Verilog-Instantiation of gates, gate symbols, and truth tables for and/or and buf/not types gates-Rise, fall and turn off delays in gate level design -Assignment statements used in data flow modeling-Different types of delays used in the data flow level-compare gate level and behavioral Design simple logic circuits like adders, subtractors using Dataflow and Gatelevelmodeling.

3. Understand the concepts of Behavioral modeling

Initial and Always statements-modeling-Blocking and Non blocking procedural assignments with examples-Timing controls like delay based timing control and event based timing control-Conditional statements-Multiway branching-Use of case, casex and casez statements-Difference between conditional if statement and case statements-Looping statements such as while, for, repeat and forever-Sequential and parallel blocks- User Defined Primitives (UDP)-combinational and sequential UDPs

4. Understand behavioral Modeling of combinational and Sequential Logic circuits

Modeling of combinational and sequential circuits-Design combinational circuits like multiplexers, decoders, encoders, comparators and ALU-Design RS, JK, T and D flip flops with asynchronous and synchronous clock and reset- Explain implementation of shift registers like SISO, SIPO, PISO, PIPO, etc-Design synchronous and asynchronous counters-Design a divide by 3 counter-Design shift register counters like ring counter, etc-Design memories like RAM and ROM-.Importance of stimulus block-Structure of stimulus module-stimulus modules for combinational and sequential circuits of Verilog designs.

5. Understand the System design concepts

Concept of Finite State Machines-Mealy and Moore types of state machines-Problems on Mealy and Moore state machines-Design of Mealy state machine using Verilog HDL. Various design tools which are useful in different stages of design-Important programmable logic devices- Architecture of PLAs - Architecture of CPLD-Architecture of FPGAs-Comparison-Applications.

Reference Books:

1. Digital systems design by Morris Mano
2. Verilog HDL: A guide to digital design and synthesis by S. Palnitkar
3. Advanced Digital Design with VERILOG HDL by Michael D. Ciletti
4. Switching and finite automation theory by ZviKohavi
5. Digital state machine design by David J. Comes
6. Digital Systems by Ronald Tocci
7. Digital design principles and practice- John F Wakerly, PHI / Pearson education Asia 3rd Edn,2005
8. Design through Verilog HDL – T.R. Padmanabhan and B. Bala Tripura Sundari, WSE, IEEE Press, 2004.
9. A Verilog Premier – J. Bhasker, BSP, 2003.
10. Fundamentals of Logic Design with Verilog – Stephen. Brown and ZvonkoVranesic, TMH, 2005.

BLUE PRINT:

SI No	Unit Title	No of Periods	Weightage Allotted	Weightage of Marks		COs mapped
				No of Essay Questions	No of Short answer Questions	
1	Introduction to Verilog HDL, Language constructs and conventions	20	26	2	2	CO1
2	Gate level and Data flow modeling	10	16	1	2	CO2
3	Behavioral modeling	15	26	2	2	CO3
4	Modeling of combinational and sequential logic circuits	15	26	2	2	CO4
5	System design concepts	15	16	1	2	CO5

	75	110	80	30	
--	----	-----	----	----	--

Table specifying the scope of syllabus to be covered for Unit Tests

Unit Test	Learning outcomes to be covered
Unit Test-I	From 1.1 to 3.6
Unit Test-II	From 3.7 to 5.13

(Model Paper)

C –23, EC -405

State Board of Technical Education and Training, A. P
Diploma in Electronics and Communication Engineering (DECE)

IV Semester

Subject Name: DIGITAL LOGIC DESIGN USING VERILOG HDL

Sub Code: **EC - 405**

Time: 90 minutes

Unit Test I

Max.Marks:40

Part-A

16Marks

- Instructions:** (1) Answer **all** questions.
(2) First question carries **four** marks, each question of remaining carries **three** marks

1. Fill the following blanks with one word

- a) HDL stands for _____ (CO 1)
- b) VLSI stands for _____ (CO 1)
- c) Write any one assignment statements in data flow modeling _____ (CO 2)
- d) Write any two types of timing controls used in Verilog HDL _____ (CO 3)
- 2. Compare VHDL and Verilog HDL (CO1)
- 3. Define expression and operator. (CO 1)
- 4. List the advantages of data flow modeling over gate level modeling (CO 2)
- 5. Differentiate between case, caseX branching statements (CO 3)

Part-B

3×8=24

Instructions: (1) Answer **all** questions.
 (2) Each question carries **eight** marks
 (3) Answer should be comprehensive and the criterion for valuation is the content but not the length of the answer.

- 6. (a) Explain the steps involved in the design flow for the VLSI IC design (CO1)
- or
- (b) Explain different data types like value set, nets, registers, vectors, integer, real and time Register data types (CO1)
- 7. (a) Explain Rise, fall and turn-off delays in the gate level modelling (CO2)
- or
- (b) Explain different types of delays used in the data flow level modelling (CO2)
- 8. (a) Explain structural procedures - initial and always statements (CO3)
- or
- (b) Explain conditional statements used in Verilog HDL (CO3)

Model Paper)

C –23, EC -405

State Board of Technical Education and Training, A. P
 Diploma in Electronics and Communication Engineering (DECE)

IV Semester

Subject Name: DIGITAL LOGIC DESIGN USING VERILOG HDL

Sub Code: **EC - 405**

Time: 90 minutes

Unit Test II

Max.Marks:40

Part-A

16Marks

Instructions: (1) Answer **all** questions.
 (2) First question carries **four** marks, each question of remaining carries **three** marks

- 1. Fill the following blanks with one word
 - a) Write any one difference between conditional if statement and case statements (CO 3)

- b) Write any one example for combinational logic circuit (CO 4)
- c) Write any one example for sequential logic circuit (CO 4)
- d) PLA stands for _____ (CO 5)
- 2. List the types of UDPs (CO 3)
- 3. Compare RTL level and structural level modeling (CO 4)
- 4. List various design tools which are useful in different stages of design (CO 5)
- 5. List any 3 applications of programmable logic devices. (CO 5)

Part-B

3×8=24

Instructions: (1) Answer **all** questions.
 (2) Each question carries **eight** marks
 (3) Answer should be comprehensive and the criterion for valuation is the content but not the length of the answer.

- 6. (a) Explain looping statements such as while, for, repeat, and forever. (CO 3)
 or
 (b) Explain combinational UDPs with example (CO 3)
- 7. (a) Design a divide by 3 counter (CO4)
 or
 (b) Explain the structure of stimulus module (CO4)
- 8. (a) Explain the architecture of CPLD (CO5)
 or
 (b) Explain the design steps for UART using FPGA board (CO5)

-oOo-

MODEL PAPER
BOARD DIPLOMA EXAMINATIONS
IV SEMESTER
Sub Code: EC – 405
Subject Name: DIGITAL LOGIC DESIGN USING VERILOG HDL
SEMESTER END EXAMINATION

TIME: 3 HOURS

MAX MARKS:80

Part-A

10×3=30

Instructions: (1) Answer **all** questions.
 (2) Each question carries **three** marks
 (3) Answer should be brief and straight to the point and shall not exceed five simple sentences.

- 1. Compare VHDL and Verilog HDL (CO1)
- 2. Define expression and operator (CO1)

3. List the advantages of data flow modeling over gate level modeling (CO2)
4. List different types of delays used in the data flow level modeling (CO2)
5. Differentiate between case, caseX branching statement (CO3)
6. List the types of UDPs (CO3)
7. Compare RTL level and structural level modeling (CO4)
8. Differentiate between Asynchronous and Synchronous Clock (CO4)
9. List various design tools which are useful in different stages of design (CO5)
10. List any 3 applications of programmable logic devices. (CO5)

Part-B

5×10=50

Instructions: (1) Answer **any Five** questions.
 (2) Each question carries **TEN** marks
 (3) Answer should be comprehensive and the criterion for valuation is the content but not the length of the answer.

11. Explain the steps involved in the design flow for the VLSI IC design (CO1)
12. Explain different data types like value set, nets, registers, vectors, integer, real and time Register data types (CO1)
13. Explain Rise, fall and turn-off delays in the gate level modelling (CO1)
14. Explain looping statements such as while, for, repeat, and forever. (CO3)
15. Explain combinational UDPs with example (CO3)
16. Design a divide by 3 counter (CO4)
17. Explain the structure of stimulus module (CO4)
18. Explain the architecture of CPLD (CO5)

-oOo-

Electronic Circuits-II Lab

Course Code	Course title	No of periods/week	Total no of periods	Marks for FA	Marks for SA
EC-406	Electronic Circuits-II Lab	03	45	40	60

S No	Unit Title	No. of Periods	COs Mapped
1	Wave Shaping Circuits	06	CO1
2	Operational Amplifier Circuits	21	CO2
3	Timers	06	CO3
4	PSpice or equivalent software simulation	12	CO4
	Total	45	

Course Objectives	1. To construct wave shaping circuits,
	2.To learn the practical importance of OP-AMP circuits .
	3.To learn the practical importance of OP-AMP timers. .
	4. To simulate wave shaping circuits, OP-AMP circuits, timers using simulation software.

CO No		COURSE OUTCOMES
CO1	EC-406.1	Construct the wave shaping circuits and observe the waveforms.
CO2	EC-406.2	Construct the Circuits using OP-AMP and observe the waveforms.
CO3	EC-406.3	Construct Timer circuits using 555 IC timer.
CO4	EC-406.4	Simulate wave shaping circuits, OP-AMP circuits, timers using P-spice or equivalent.

CO-PO/PSO MATRIX

CO No	PO1	PO2	PO3	PO4	PO5	PO6	PO7	PSO1	PSO2	PSO3
EC-406.1	3		2			3		3		
EC-406.2	3	2	2		2	3		3	2	2
EC-406.3	3	2	2		2	3		3	2	2
EC-406.4	3	2	2		2	3		3	2	2
Average	3	2	2	3	2	3	3	3	2	2

3=strongly mapped 2=moderately mapped 1=slightly mapped

LEARNING OUTCOMES:

I. Wave shaping circuits

- 1.Construct different Positive and negative clipper circuits and obtain output waveforms with sinusoidal input
2. Realize a Clamper circuit and observe the input and output waveforms on CRO

II. Operational Amplifier Circuits

3. Implement and test 741 Op-Amp as a) inverting amplifier, b) Non Inverting amplifier and c) Voltage follower (Buffer) – observe wave forms
4. Implement and test 741 Operation amplifier as a) Summer b) Differentiator c) Integrator
5. Implement Monostable using Op-Amp and observe output waveform on CRO
6. Implement Astable multivibrator using Op-Amp and observe output waveform on CRO
7. Construct multi tone bell using IC 741 OP-AMP and observe the changes in the tone and the output of bell

8. Implement Schmitt trigger using Op-Amp and observe output waveform on CRO
9. Implement RC-phase shift oscillator Circuit using Op-Amp and observe output waveform on CRO
10. Implement Wien bridge oscillator Circuit using Op-Amp and observe Output waveform on CRO

III. 555 Timer

- 10 Implement Astable multi vibrator using 555 IC and observe output waveform on CRO
11. Construct LED sequencer using IC 555 and observe the sequence of running LEDs (Use 8 LEDs)

IV. PSpice or equivalent software simulation

12. Simulate Double sided clipper using diodes
13. Simulate a) Summer b) Differentiator c) Integrator and c) Scale changer using Op-Amp
14. Simulate Monostable multivibrator using Op-Amp
15. Simulate Astable multivibrator using 555 IC

MICROCONTROLLERS AND INTERFACING LAB

Course Code	Course title	No of periods/week	Total no of periods	Marks for FA	Marks for SA
EC-407	MICROCONTROLLERS AND INTERFACING LAB	03	45	40	60

S.No	Unit Title	No. of Periods	COs Mapped
1	Familiarization with Keil software and Microcontroller Kit	03	CO1
2	Basic programming using Microcontroller kit/Keil	15	CO2
3	Interfacing I/O devices with 8051 using Embedded C	18	CO3
4	Application development using Proteus/equivalent software	06	CO4

5	Dumping/Burning into Microcontroller chip	03	CO4
	Total	45	

Course Objectives	1. To familiarize with 8051 Microcontroller kit and Keil compiler
	2. To understand the programming and interfacing concepts of 8051 Microcontroller
	3. To learn the practical importance and applications of programming and interfacing of 8051 Microcontroller chip

CO No		COURSE OUTCOMES
CO1	EC-407.1	Describe the usage of 8051 Microcontroller kit and Keil Compiler
CO2	EC-407.2	Apply Instruction set of 8051 Microcontroller in AL programming
CO3	EC-407.3	Apply Instruction set of 8051 Microcontroller for interfacing of I/O devices
CO4	EC-407.4	Simulate Interfacing circuits using Proteus and learn the burning of firmware into Microcontroller chip

CO-PO/PSO MATRIX

CO No	PO1	PO2	PO3	PO4	PO5	PO6	PO7	PSO1	PSO2	PSO3
EC-407.1	3	3	3	3			3	3	3	
EC-407.2	3	3	3	3	3			3	3	3
EC-407.3	3	3	3	3	3	1	3	3	3	3
EC-407.4	3	3	3	3	3	1	3	3	3	3
Average	3	3	3	3	3	1	3	3	3	3

3=strongly mapped 2=moderately mapped 1=slightly mapped

LEARNING OUTCOMES:

I. Familiarization with Microcontroller Kit & Simulators

1. Familiarize with 8051 Microcontroller Kit
2. Familiarize with 8051 simulator KEIL (or equivalent software)

II. Basic programming using Microcontroller kit/Keil

1. Write an ALP to perform Block move - 10bytes of data from 0X30-0X39 to 0X40-0X49
2. Write an ALP to perform Block exchange – 10bytes of data between 0X30-0X39 to 0X40-0X49
3. Write an ALP to perform: Addition , subtraction , division and multiplication of two 8 bit numbers
4. Write an ALP to perform addition of two16-bit numbers
5. Write an ALP to perform subtraction of two16-bit numbers
6. Write an ALP to the find Smallest/Largest number in 10bytes of data stored from 0X30 to 0X39 and store the result in the next location i.e., 0X3A

7. Write an ALP to find the 2's complement of given 8-bit number

III. To practice Interfacing Techniques using Embedded C

8. Write a program to make an LED connected to port pin P1.5, light up for specific time on pressing a switch connected to port pin P2.3
9. Write a Program to make an LED connected to pin P1.7 to blink at a specific rate
10. Interface a 7 segment LED display with 8051 microcontroller and write a program to display a given decimal digit
11. Interface a small DC motor with 8051 and write a program to rotate the motor in clockwise/anti clockwise direction

IV. Application development using proteus/equivalent software

12. Familiarization of firmware based application with proteus/equivalent software
13. Perform experiments given in 10 and 11 above using proteus

V. Dumping/Burning into Microcontroller

14. Perform burning/loading of .HEX file of experiments given in 10 and 11 above into flash memory for 89C51 and test it in development kit

COMMUNICATION SKILLS

Course Code	Course Title	No. of Periods/Week	Total No. of Periods	Marks for FA	Marks for SA
EC-408	Communication Skills	3	45	40	60

Course Objectives: The students shall

- communicate effectively in diverse academic, professional and everyday situations
- exhibit appropriate body language and etiquette at workplace
- be employable through preparing appropriate job applications and attend interviews confidently with all necessary skills

Course Outcomes: The students shall

CO1: Listen and comprehend the listening inputs related to different genres effectively

CO2: Communicate effectively in interpersonal interactions, interviews, group discussions and presentations

CO3: Acquire employability skills: job hunting, resume writing, attending interviews

CO4: Practise appropriate body language and professional etiquette

Course Delivery: Text book: “**Communication Skills**”

by State Board of Technical Education and Training, AP

SI No	Unit	Teaching Hours
1	Listening Skills	6
2	Work place Etiquette	3
3	Introduce oneself	3
4	Short presentation (JAM)	6
5	Group Discussion	6
6	Resume Writing and Cover Letter	3
7	Interview Skills	9
8	Presentation Skills	9
<i>Total</i>		45

Course Content:

UNIT 1: Listening Skills

6 periods

Pre – While- Post-listening activities- Listening to audio content (dialogues/ speech/ narrations) - answering the questions and fill in the blanks- vocabulary

UNIT 2: Work place Etiquette

3 periods

Basics of Etiquette- politeness/ courtesy, good manners- features of work place etiquette- adaptability, positive attitude, body language.

UNIT 3: Introducing Oneself

3 periods

Speak about oneself - introduce oneself to a gathering/ formal & informal situations- Know about others- filling in the grid- introducing oneself in interviews

UNIT 4: Short Presentation

6 periods

Dos and Don'ts in short presentation- speak for a minute without repetition, deviation & hesitation - the techniques to speak fluently – defining and describing objects, people, phenomena, events.- speaking on randomly chosen topics.

UNIT 5: Group Discussion

6 periods

Fundamentals of Group Discussion- Dos and Don'ts- filling the Grid- possible list of topics- practice sessions- sample videos-Group activity

UNIT 6: Resume Writing and Cover Letter

3 periods

Pre activity: answer the questions- jotting down biographical information- sample resumes- tips, Dos and Don'ts- model resumes- practice exercises on Resume writing

UNIT 7: Interview Skills

9 periods

Pre –while-post activities: - things to do at three stages – respond to notifications- know the information about the organisation-practice FAQs - preparation of good/ suitable C V, Body language, tips for success in interviews, model / mock interviews.

UNIT 8: Presentation Skills

9 periods

Preparatory work: observe pictures and answer questions- different kinds of presentations- PPTs, Flash cards, Posters, Charts. - tips to prepare aids, slide show, model PPTs, - checklist on pre, while and post presentations.

Mapping Course Outcomes with Programme Outcomes:

PO	1	2	3	4	5	6	7
CO	POs 1 to 5 are applications of Engineering Principles, can't be directly mapped to Communication Skills					1,2,3,4	1,2,3,4

CO –PO Mapping

CO	Course Outcome	Cos / Unit Mapped	POs mapping	Cognitive levels as per Bloom's Taxonomy R/U/A/An (Remembering / Understanding / Applying/ Analysing)
CO 1	Listen and comprehend listening inputs related to different genres effectively	Unit 1	6,7	R/U/A
CO2	Communicate effectively in interpersonal interactions, interviews, group discussions and presentations	3,4,5,7,8	6,7	R/U/A/An
CO3	Acquire employability skills: job hunting, resume writing, attending interviews	6,7	6,7	R/U/A/An
CO4	Practise appropriate body	2, 3,	6,7	R/U/A

	language and professional etiquette	4,5,7,8		
--	-------------------------------------	---------	--	--

ASSESSMENT

C23-Common-408: English Communication Skills Lab

- The assessment for C23-Common 408 : ‘English Communication Skills’ is on par with all other practical subjects comprising 40 marks for Internal assessment and 60 marks for External examination attaining the final total of 100 Marks.
- The Internal Assessment can be conducted in the form of Assignments in all the 8 Units. One or Two assignments can be conducted in each Unit, awarding 10 marks for each assignment and the total marks can be averaged to 40 marks as suggested below.
- These assignments should focus mostly on LISTENING and SPEAKING skills rather than writing. However, for the practice sake, students can write down their assignments in a separate note book to enable them speak/present in the end exam fluently. The students should submit these assignment note books to the teacher.
- Questioning styles vary from Unit to Unit as different skills are assessed in each Unit with specific parameters as given in the workbook.
- Listening skills can be tested by playing different Audio/ Video clips (appropriate in content and language, preferably without subtitles) and test their skill of listening comprehension . Follow pre-while-post stages of listening activity and students should answer general, specific, inferential, vocabulary questions.
- Personal profile, describing a place/a thing/ a person/ an event / a picture, JAM, presentations, Direct interaction with the teacher/ examiner are the topics for individual speaking skills.
- Role plays, GD and Interview skills should be made as group activities and the teacher assesses various skills of the students as given in the workbook.
- Teacher should maintain a record of the following Assessment sheet (one for each student) to award Internal marks.

Calculating Internal marks through Assignments :					
Name of the Student:		PIN:	Branch:	Academic Year:	
S. No.	Title of the Unit	Assignment 1: 10 Marks	Assignment 2: 10 Marks	Total Marks in each Unit (Average for 10 Marks)	
1	Listening Skills				
2	Workplace etiquette				
3	Introducing Oneself				
4	Short Presentations (JAM)				
5	Group Discussion				
6	Resume & Cover Letter				
7	Interview Skills				
8	Presentation Skills				
	Marks Scored				Ex: 65

	Total No. of Units		8
	Internal Assessment : Average for 40 Marks	(65/8) X4 = 32.5	33 (for 40 Marks)

End Exam Model paper: C23-Common-408 : Communication Skills Lab

Guidelines to prepare the question paper of the Lab End exam for 60 marks:

I. Listening Skills:

Students listen to the audio / watch the video clip (without subtitles) and answer the questions supplied to them in advance; observe the three stages of the Listening activity.
: 10 Marks

II. Individual Speaking skills:

a) Speak for a minute (JAM) on the given topic, can be allotted through chits/lots: 10 M. b) Individual speaking skills on any given topicdescriptions / role play etc: 10 Marks

c) Direct Interaction/ dialogue with the examiner to test his/her speaking skills : 10 M.

III. Pair / Group Speaking Activities. : 20 Marks

a) Role Plays / dialogue making

b) Group Discussion

c) Interview skills

Note: If the students are more in number and the time is not sufficient to conduct the Viva for all the students in a single spell, the examiner can also adapt the blended mode of exam. A few significant questions can be tested orally and one or two questions can be answered in writing. (Ex: Resume, cover letter, FAQs in Interview skills etc.) along with the answers of Listening Test.

Aspects to be evaluated to test speaking skills			
S.No	Language Aspects	Organising Aspects	Body Language aspects
1	Content: Quality, clarity and relevance of ideas	Coherence, cohesion of relevant ideas	Postures
2	Fluency	Proper beginning, topic sentence, expansion/details, conclusion	Gestures,
3	Vocabulary	Using proper Linkers	Eye contact
4	Pronunciation	Avoid repetitions, clichés, fillers	Audibility, pitch, Permissible pauses
5	Grammar (Syntax, semantics)		Other Permissible body movements

IOT AND SENSORS LAB

Course Code	Course title	No of periods/week	Total no of periods	Marks for FA	Marks for SA
EC-409	IOT AND SENSORS LAB	03	45	40	60

S.No	Unit Title	No. of Periods	COs Mapped
1	Familiarization with Esp8266 Board (or equivalent Board)	03	CO1
2	Basic Interfacing programming using Esp8266 and Blynk IoT	30	CO2
3	Application development using Esp8266 and Blynk IoT	12	CO3
	Total	45	

Course Objectives	1. To Familiarization with Esp8266 Board (or equivalent Board) and Blynk IoT
	2. To interface sensors using Esp8266 and Blynk IoT
	3. To learn the practical importance and Application development using Esp8266

	and Blynk IoT
--	----------------------

CO No		COURSE OUTCOMES
CO1	EC-409.1	Describe the usage of Esp8266 and Blynk IoT Platform
CO2	EC-409.2	Apply Interfacing using Esp8266 and Blynk IoT
CO3	EC-409.3	Apply Application development using Esp8266 and Blynk IoT

CO-PO/PSO MATRIX

CO No	PO1	PO2	PO3	PO4	PO5	PO6	PO7	PSO1	PSO2	PSO3
EC-409.1	3	3	3	3			3	3	3	
EC-409.2	3	3	3	3	3			3	3	3
EC-409.3	3	3	3	3	3	2	3	3	3	3
Average	3	3	3	3	3	2	3	3	3	3

3=strongly mapped 2=moderately mapped 1=slightly mapped

LEARNING OUTCOMES:

I. Familiarization with Esp8266 Board (or equivalent Board)

1. Familiarize with Esp8266 Board(NodeMCU)
2. Familiarize with ARDUINO IDE (or equivalent software)
3. Familiarize with Blynk IoT (or equivalent software)

II. Basic Interfacing programming using Esp8266 and Blynk IoT

4. Interface LED with Esp8266 and control it through mobile using Blynk IoT app
5. Interface DHT11 sensor with Esp8266 and display temperature in Blynk IoT app
6. Interface DHT11 sensor with Esp8266 and display humidity in Blynk IoT app
7. Interface Ac load with Esp8266 and control it through Blynk IoT app
8. Interface Ultrasonic sensor with Esp8266 to measure the distance from the target and display it in Blynk IoT app
9. Interface soil moisture sensor with Esp8266 to measure the percentage of soil moisture and display it in Blynk IoT app
10. Interface servo motor with Esp8266 and rotate it (0-180°) .

III.Application development using Esp8266 and Blynk IoT

11. Interface temperature sensor with Esp8266 and turn on the fan when temperature exceeds the threshold level ,and observe the status of temperature and fan through IoT.
12. Build a Webserver on Esp8266 to control LED
13. Build any small prototype by using any three sensors mentioned above and Blynk IoT.

DIGITAL LOGIC DESIGN THROUGH VERILOG HDL LAB

Course Code	Course Title	No. of Periods/Week	Total No. of Periods	Marks for FA	Marks for SA
EC-410	DIGITAL LOGIC DESIGN THROUGH VERILOG HDL LAB	3	45	40	60

S No	Unit Title	No. of Periods	COs Mapped
1	Familiarization with Xilinx ISE/Vivado (or) similar software	06	CO1
2	Implementing Basic logic gates	9	CO2
3	Implementing Combinational Circuits	9	CO3
4	Implementing Sequential Circuits such as Flipflops, Registers & counters	21	CO4
	Total	45	

Course Objectives	1. To familiarize with with Xilinx ISE/Vivado (or) similar software
	2. To Implement Basic logic gates, Combinational Circuits

	3. To implement Sequential Circuits such as Flipflops, Registers & counters
--	---

CO No		COURSE OUTCOMES
CO1	EC-410.1	Work with Xilinx ISE/Vivado (or) similar software
CO2	EC-410.2	Implement Basic logic gates
CO3	EC-410.3	Implement Combinational Circuits
CO4	EC-410.4	Implement Sequential Circuits such as Flipflops, Registers & counters

Course Contents:

Using Xilinx ISE/Vivado (or) similar software

I. Implementing Basic logic gates

1. Implement Basic Logic Gates
2. Implement Adders(Half adder and Full Adder)
3. Implement Subtractors(Half Subtractor and Full Subtractor)

II. Combinational Circuits

4. Implement 4-bit Parallel Adder
5. Implement Multiplexers (2:1, 4:1 and 8:1 MUX)
6. Implement Demultiplexers (1:2, 1:4 and 1:8 DEMUX)
7. Implement Decoders (1:2, 2:4 and 3:8 Decoder)
8. Implement Encoders (2:1, 4:2 and 8:3 encoder)
9. Implement Comparator (2-bit and 4-bit)
10. Implement ALU

III. Sequential Circuits

11. Implement Flip Flops (JK- Flip Flop and SR-Flip flop)
12. Implement Flip Flops (D- Flip Flop and T-Flip flop)

IV. Registers & counters

13. Implement Shift Registers (SISO, SIPO)
14. Implement Shift Registers (PISO, PIPO)
15. Implement Counter (BCD and Decimal Counters)

-0o0-

V SEMESTER

FIFTH SEMESTER

DIPLOMA IN ELECTRONICS & COMMUNICATION ENGINEERING SCHEME OF INSTRUCTIONS AND EXAMINATIONS V SEMESTER

Subject Code	Name of the Subject	Instruction period / week		Total Periods / Sem	Scheme of Examination			
		Theory	Practical/Tutorial		Duration (hours)	Sessional Marks	End Exam Marks	Total Marks
THEORY								
EC -501	Industrial Management & Entrepreneurship	4		60	3	20	80	100
EC-502	Embedded Systems	5	-	75	3	20	80	100
EC-503	Optical & Mobile Communications	5	-	75	3	20	80	100
EC-504	Industrial Electronics & Automation	5	-	75	3	20	80	100
EC-505	Data Communication & Computer Networks	5	-	75	3	20	80	100
PRACTICAL								

EC-506	Embedded Systems lab	-	3	45	3	40	60	100
EC-507	Industrial Electronics & Automation Lab	-	3	45	3	40	60	100
EC-508	Life Skills	-	3	45	3	40	60	100
EC-509	Data Communication & Computer Networks	-	3	45	3	40	60	100
EC-510	Project Work	-	3	45	3	40	60	100
	Activities		3	45	-	-	-	-
	TOTAL	24	18	630	-	300	700	1000

INDUSTRIAL MANAGEMENT & ENTREPRENEURSHIP

Course Code	Course title	No of periods/week	Total no of periods	Marks for FA	Marks for SA
EC-501	INDUSTRIAL MANAGEMENT & ENTREPRENEURSHIP	04	60	20	80

S.No	Unit Title	No.of Periods	CO'S Mapped
1	Basics of Industrial Management, Organisation structure & Organisational behaviour	10	CO1
2	Electronic Product design and Development stages	13	CO2
3	Electronic Product testing & documentation	15	CO3
4	Entrepreneurship Development.	12	CO4
5	Industrial Safety	10	CO5
Total Periods		60	

COURSE OBJECTIVES:

COURSE OBJECTIVES	<ol style="list-style-type: none"> 1. To familiarise the concepts of management, ownership styles, organisation structures and Industrial safety. 2. To get Exposure to organisational behavioural concepts, basics of Electronic Product design, Development, testing and documentation stages in Electronic industries. 3. To understand the concept Entrepreneurship Development in industries.
--------------------------	---

COURSE OUTCOMES:

CO No		COURSE OUTCOMES
CO1	EC-501.1	Explain the basics of management, Organisation structure & Organizational behaviour as applied to industry
CO2	EC-501.2	Explain Product Design and Development Stages applied to electronic industries
CO3	EC-501.3	Analyse the testing standardisation for Electronic products.
CO4	EC-501.4	Describe the role of entrepreneur in economic development and in improving the quality of life
CO5	EC-501.5	Explain about Industrial Safety

CO-PO/PSO MATRIX

CO No	PO1	PO2	PO3	PO4	PO5	PO6	PO7	PSO1	PSO2	PSO3
EC-501.1	1							1		
EC-501.2	3	2	3		2		2	3	2	2
EC-501.3	3	2	3	3	2		2	3	2	2
EC-501.4	1				1			1		3
EC-501.5	3	2		2	2		0	2		2
Average	2.20	3.00	3.00	2.50	1.75		1.33	2.00	1.33	2.25

3=strongly mapped 2=moderately mapped 1=slightly mapped

LEARNING OUTCOMES:

1. Basics of Industrial Management, Organization Structure & organizational behaviour

- 1.1 Define industry, commerce (Trade) and business.
- 1.2 State the need for management.
- 1.3 State the functions of Management.
- 1.4 Explain the principles of scientific management.
- 1.5 Differentiate: i) management and administration.
ii) Supervisory, middle and top level management
- 1.6 Explain the line, staff and Functional organization structures.
- 1.7 State motivation theories.
- 1.8 Explain Maslow's Hierarchy of needs.
- 1.9 List out different leadership models.
- 1.10 Explain the trait theory of leadership and behavioural theory of Leadership
- 1.11 Explain the process of recruitment and selection.
- 1.12 Explain different types of business ownerships and compare them
- 1.13 Define social responsibilities and Corporate social responsibility

2. Electronic Product design and Development stages

- 2.1 Explain the concept of product development with a block diagram.
- 2.2 Give classification of Electronic Products.
- 2.3 Explain the Techno Commercial Feasibility of a product.
- 2.4 Explain customer requirements
- 2.5 Explain R&D prototype Assessment of reliability.
- 2.6 Explain factors for reliability of equipment.
- 2.7 Explain quality considerations.
- 2.8 List reasons for failure of an electronic product
- 2.9 Explain Bath tub curve
- 2.10 Explain Product packaging and storage
- 2.11 Estimate power supply requirements of an electronic product
- 2.12 List two types of power supply protection devices
- 2.13 Define noise reduction.
- 2.14 Explain grounding, shielding and guarding techniques
- 2.15 Explain Thermal management

3. Electronic Product testing & documentation

- 3.1 Explain the importance of product testing and Environmental testing
- 3.2 Explain Dry heat testing, Vibration testing, random testing and Bump testing
- 3.3 Explain Temperature extreme testing for linear and step stress profiles
- 3.4 Explain Vibration & temperature cycling
- 3.5 Explain EMI and EMC compliance testing standardization
- 3.6 Explain UL and CE Certification of industrial electronic products.
- 3.7 Explain the importance of documentation
- 3.8 List types of documentation
- 3.9 Explain types of documents
- 3.10 List rules for preparation of effective document
- 3.11 Explain PCB documentation
- 3.12 Explain Assembly and fabrication related documentation for Laminate grade
- 3.13 Explain the preparation a manual document
- 3.14 Explain the details of service manual
- 3.15 Explain test report/manuals
- 3.16 Explain product documentation, Bill of materials, Production test specifications

4. Entrepreneurship Development.

- 4.1 Define the word entrepreneur.
- 4.2 Explain the requirements of an entrepreneur.
- 4.3 Determine the role of entrepreneurs in promoting Small Scale Industries.
- 4.4 Describe the details of self-employment schemes.
- 4.5 List the financial assistance programmes.
- 4.6 List out the organisations that help an entrepreneur
- 4.7 Explain the use of EDP Programmes
- 4.8 Understand the concept of make in India, Zero defect and zero effect
- 4.9 Understand the importance for start ups
- 4.10 Explain the conduct of demand surveys

- 4.11 Explain the conduct of a market survey
- 4.12 Evaluate Economic and Technical factors.
- 4.13 What is the feasibility study in project management
- 4.14 What is the advantages of feasibility study
- 4.15 Prepare feasibility report study

5. Industrial Safety

- 5.1 Explain the importance of safety in the industry.
- 5.2 Explain the principles of 5S safety system.
- 5.3 Explain the major hazards which may arise from the use of electrical equipment
- 5.4 Explain the precautions to be taken to prevent accidents while using Machines
- 5.5 Explain method of first aid treatment for someone suffering from electric shock.
- 5.6 State general electrical safety rules
- 5.7 Explain the safety signs and colours
- 5.8 Show various safety symbols and explain their meaning.
- 5.9 Explain the causes of Fire and fire accidents in industry.
- 5.10 Explain Fire prevention measures.
- 5.11 List four types of Portable fire extinguishers
- 5.12 Explain the choice of above extinguishers.
- 5.13 Explain the First aid treatment in the case of burns

COURSE CONTENT

1. Basics of Industrial Management, Organisation Structure & organisational behaviour

Introduction: Industry, Commerce and Business; Definition of management; Functions of management - Principles of scientific management: –Administration and management;- levels of management; Organisation structure- behaviour of individual in an organisation-delegation an decentralisation- effective organisation- Motivational Theories; -Leadership Models; -decision making-Human resources requirement- process of recruitment, selection - Forms of Business ownerships - Social responsibility and Corporate Social responsibility

2. Electronic Product design and Development stages:

Introduction, Explain The Techno Commercial Feasibility of specifications, Explain R&D prototype Assessment of reliability, Estimating power supply requirements, Power supply protection devices, Noise reduction, Grounding, Shielding and guarding techniques, Thermal management,

3. Electronic Product testing and Documentation:

Introduction to product testing, Environmental testing: Dry heat, Vibration temperature cycling, Bump and Humidity tests as specified in IS standards, EMI EMC compliance testing standardization, UL and CE Certification of industrial electronic products-PCB documentation, Assembly and fabrication related documentation Laminate grade, product documentation User manual service maintenance manual Bill of materials Production test specifications

4. Entrepreneurship Development.

Definition of Entrepreneur; Role of Entrepreneur; Concept of Make In India, ZERO defect, Zero Effect, Concept of Start-up Company, Entrepreneurial Development: Role of SSI, MSME, DICs, Entrepreneurial development schemes; Institutional support, financial assistance programmes; Market survey and Demand survey; Preparation of Feasibility study reports

5. Industrial Safety

Importance of safety in the industry-the principles of 5S safety system-the major hazards which may arise from the use of electrical equipment-precautions to be taken to prevent accidents while using Machines - method of first aid treatment for someone suffering from electric shock- general electrical safety rules-the safety signs and colours-various safety symbols and explain their meaning-causes of Fire and fire accidents in industry-Fire prevention measures-types of Portable fire extinguisher-choice of above extinguishers-the First aid treatment in the case of burns

REFERENCE BOOKS

1. O.P Khanna, Industrial Engineering and Management
2. Buffa, Production Management
3. Banga& Sharma, Engineering Economics and Management Science
4. Flippo, Personnel Management
5. S.N. Chary, Production and Operations Management
6. Converging_Technologies_for_Smart_Environments_and_Integrated_Ecosystems_IERC_Book_Open_Access_2013 pages-54-76
7. Electronic Product Design, R.G.Kaduskar, V.B.Baru, Wiley India
8. Electronic testing and fault diagnosis –G.C. Loveday (Ah wheeler Publication, India)

BLUE PRINT

SI No	Unit Title	No of Periods	Weightage Allotted	Weightage of Marks		COs mapped
				No of Essay Questions	No of Short answer Questions	
1	Basics of Industrial Management, Organisation structure & Organisational behaviour	10	26	2	2	CO1
2	Electronic Product design and Development stages	13	26	2	2	CO2
3	Electronic Product testing & documentation	15	26	2	2	CO3
4	Entrepreneurship Development.	12	16	1	2	CO4
5	Industrial Safety	10	16	1	2	CO5
		60	110	80	30	

Table specifying the scope of syllabus to be covered for Unit Tests

Unit Test	Learning outcomes to be covered
Unit Test-I	From 1.1 to 3.8
Unit Test-II	From 3.9 to 5.13

(Model Paper) **C –23, EC -501**
State Board of Technical Education and Training, A. P
Diploma in Electronics and Communication Engineering (DECE)
V Semester
Subject Name: Industrial Management & Entrepreneurship
Sub Code: EC - 501

Time: 90 minutes

Unit Test I

Max.Marks:40

Part-A

16Marks

Instructions: (1) Answer **all** questions.
(2) First question carries **four** marks; each question of remaining carries **three** marks

1. Answer the following questions with **one word** only
 - a) Name any one business owner ship (CO1)
 - b) Name any one power supply protection device (CO2)
 - c) Name any one leadership model (CO1)
 - d) Name any one functional organization (CO1)
2. List out different leadership models. (CO1)
3. Distinguish between management and administration (CO1)
4. Define noise reduction (CO2)

5. Describe any three customer requirements (CO2)

Part-B

3×8=24

- Instructions:** (1) Answer **all** questions.
(2) Each question carries **eight** marks
(3) Answer should be comprehensive and the criterion for valuation is the content but not the length of the answer?

6. (a) Explain the trait theory of leadership and behavioural theory of Leadership (CO1)
Or
(b) Explain the principles of scientific management (CO1)
7. (a) Explain the Techno Commercial Feasibility of a product (CO2)
Or
(b) Explain grounding, shielding and guarding techniques (CO2)
8. (a) Explain different types of business ownerships and compare them (CO1)
Or
(b) Explain the concept of ergonomic and aesthetic considerations of pilot production (CO2)

-oOo-

(Model Paper)

C –23, EC -501

State Board of Technical Education and Training, A. P
Diploma in Electronics and Communication Engineering (DECE)
V Semester
Subject Name: Industrial Management & Entrepreneurship
Sub Code: EC - 501

Time: 90 minutes

Unit Test II

Max.Marks:40

Part-A

16Marks

- Instructions:** (1) Answer **all** questions.
(2) First question carries **four** marks; each question of remaining carries **three** marks

1. Answer the following questions with one word
- a) Write full form of EMI and EMC (CO2)
- b) Write any one characteristic of successful entrepreneurs (CO4)
- c) Which type of fire extinguisher is used for electrical hazard (CO5)
- d) Which type of colour is used for warning signs (CO5)
2. Give any three details of service manual (CO3)
3. State the rules needed for preparation of effective document (CO3)
4. Describe any three financial assistance programmes for the entrepreneurship (CO4)
5. Draw the safety symbols to indicate flammables, explosives and radioactive (CO5)

Part-B

3×8=24

- Instructions:** (1) Answer **all** questions.
(2) Each question carries **eight** marks
(3) Answer should be comprehensive and the criterion for valuation is the content but not the length of the answer.
6. (a) Explain EMI and EMC compliance testing standardization (CO3)
Or
(b) Explain Assembly and fabrication related documentation for Laminate grade (CO3)
7. (a) Explain the use of EDP Programmes (CO4)
Or
(b) Explain the conduct of a market survey (CO4)
8. (a) Explain the precautions to be taken to prevent accidents while using Machines (CO5)
Or
(b) Explain method of first aid treatment for someone suffering from electric shock (CO5)

-oOo-

MODEL PAPER
BOARD DIPLOMA EXAMINATIONS
C-23, EC-501, INDUSTRIAL MANAGEMENT & ENTREPRENEURSHIP
V SEMESTER
SEMESTER END EXAMINATION

TIME: 3 HOURS

MAX MARKS: 80

Part-A

10×3=30

- Instructions:** (1) Answer **all** questions.
(2) Each question carries **three** marks
(3) Answer should be brief and straight to the point and shall not exceed Five simple sentences.
1. Define industry, commerce (Trade) and business. (CO1)
2. Distinguish between delegation and decentralization (CO1)
3. Define noise reduction (CO2)
4. State Dry heat testing (CO2)
5. State the rules needed for preparation of effective document (CO3)
6. List types of documentation (CO3)
7. Define the word entrepreneur (CO4)
8. State any three financial assistance programmes for the entrepreneurship (CO4)
9. List 4 types of Portable fire extinguishers (CO5)

10. Draw the safety symbols to indicate flammables, explosives and radioactive (CO5)

Part-B

5×10=50

- Instructions:** (1) Answer **any 5** questions.
 (2) Each question carries **ten** marks
 (3) Answer should be comprehensive and the criterion for valuation is the content but not the length of the answer?

11. Explain the trait theory of leadership and behavioural theory of Leadership (CO1)
 12. Explain the principles of scientific management (CO1)
 13. Explain the Techno Commercial Feasibility of a product. (CO2)
 14. Explain grounding, shielding and guarding techniques (CO2)
 15. Explain R&D prototype Assessment of reliability. (CO3)
 16. Explain Bath tub curve (CO3)
 17. Explain the use of EDP Programmes (CO4)
 18. Explain method of first aid treatment for someone suffering from electric shock (CO5)

-oOo-

EMBEDDED SYSTEMS

Course Code	Course title	No of periods/week	Total no of periods	Marks for FA	Marks for SA
EC-502	EMBEDDED SYSTEMS	05	75	20	80

S No	Unit Title	No. of Periods	COs Mapped
1	Introduction to Embedded systems	10	CO1
2	Communication Standards And Real Time Operating System	15	CO2
3	ARM Cortex M3 Architecture	15	CO3
4	ARM - Instruction set and programming	15	CO4
5	ARM Interfacing	10	CO5
	Total	75	

Course Objectives	To introduce Embedded systems and to explain Communication Standards And Real Time Operating System
	To understand ARM Cortex M3 Architecture, Memory and Peripherals
	To learn ARM - Instruction set and programming

CO No	COURSE OUTCOMES
-------	-----------------

CO1	EC-502.1	Introduce to Embedded systems
CO2	EC-502.2	Know about Communication Standards And Real Time Operating System
CO3	EC-502.3	Understand ARM Cortex M3 Architecture
CO4	EC-502.4	Learn Memory and Peripherals
CO5	EC-502.5	Learn ARM - Instruction set and programming

CO-PO/PSO MATRIX

CO No	PO1	PO2	PO3	PO4	PO5	PO6	PO7	PSO1	PSO2	PSO3
EC-502.1	3							3		
EC-502.2	3	3						3		
EC-502.3	3	3	3		3			3	3	3
EC-502.4	3	3	3		3		2	3	3	3
EC-502.5	3	3	3		3		3	3	3	3
Average	3	3	3		3		2.5	3	3	3

3=strongly mapped

2=moderately mapped

1=slightly mapped

LEARNING OUTCOMES:

1.0. INTRODUCTION TO EMBEDDED SYSTEMS

- 1.1. Define Embedded System
- 1.2. Compare Embedded System and General Computing System
- 1.3. List five Application areas of Embedded System
- 1.4. Draw and explain the general block diagram of an embedded system
- 1.5. Explain Harvard and Von-Neumann architecture.
- 1.6. State the features of CISC architecture
- 1.7. State the features of RISC architecture
- 1.8. Compare the features of RISC and CISC architectures
- 1.9. Classify embedded systems
- 1.10. Explain Core of the Embedded System
- 1.11. Explain Memory management in Embedded System
- 1.12. Explain Embedded Firmware

2.0 COMMUNICATION STANDARDS AND REAL TIME OPERATING SYSTEM

- 2.1 Explain about SPI, I2C, UART communication communication protocols
- 2.2 Explain Operating System Basics
- 2.3 Compare general OS and RTOS
- 2.4 List three Types of RTOS
- 2.5 List the features of RTOS
- 2.6 Explain Real Time Operating System
- 2.7 List the characteristics of RTOS

- 2.8 Explain Tasks, Process and Threads
- 2.9 Explain task management and scheduling
- 2.10 Explain resource allocation and interrupt handling
- 2.11 Define Multi Processing and Multi Tasking

3.0 ARM CORTEX M3 ARCHITECTURE

- 3.1. List ARM cortex families.
- 3.2. Compare different types of ARM cortex series.
- 3.3. List the features of ARM cortex M3
- 3.4. List the applications of ARM cortex M3
- 3.5. Draw and explain the architecture of ARM cortex M3
- 3.6. List the general purpose and special purpose registers of ARM cortex M3
- 3.7. Explain ARM cortex M3 processor operating modes with switching diagrams
- 3.8. List interrupts in ARM cortex M3
- 3.9. Explain about Interrupt Vector controller of ARM cortex M3
- 3.10. List the differences between Exceptions and Interrupts
- 3.11. Explain about handling of exceptions and interrupts of ARM cortex M3
- 3.12. Define interrupts tail chaining in ARM
- 3.13. Explain about system stack architecture of ARM cortex M3
- 3.14. Explain about reset sequence in ARM cortex M3
- 3.15. Explain about pipeline architecture and data path of ARM cortex M3
- 3.16. Define Memory endianness in ARM cortex M3
- 3.17. Define bit banding in ARM cortex processor
- 3.18. Explain about memory address mapping of ARM cortex M3

4.0 ARM - INSTRUCTION SET AND PROGRAMMING

- 4.1. Draw the generalized instruction format of ARM cortex M3
- 4.2. Classify the instruction set of ARM cortex M3
- 4.3. Explain the data processing instructions of ARM cortex M3
- 4.4. Explain the memory access instructions of ARM cortex M3
- 4.5. Explain the multiply and divide instructions of ARM cortex M3
- 4.6. Explain the bit field instructions of ARM cortex M3
- 4.7. Explain the branch and control instructions of ARM cortex M3
- 4.8. Explain the Saturating instructions of ARM cortex M3
- 4.9. Write a program to illustrate the application of data processing instructions
- 4.10. Write a program to perform addition, subtraction, multiplication and division
- 4.11. Write a program to perform branch control operations

5.0 ARM INTERFACING

- 5.1 Explain about GPIO interfacing of ARM cortex M3
- 5.2 Explain about ADC and DAC interfacing and their usage and applications (Voltage measurement, sinewave generation).
- 5.3 Explain about ARM peripherals: i) Timer ii) Watchdog timer iii) Sys Tick iv) PWM v) Internal RTC

- 5.4 Explain about Interfacing LEDs and switches of ARM cortex M3
- 5.5 Explain about interfacing seven segment display of ARM cortex M3
- 5.6 Explain about keypad interfacing of ARM cortex M3
- 5.7 Explain about LCD interfacing of ARM cortex M3

COURSE CONTENT

1. INTRODUCTION TO EMBEDDED SYSTEM AND RTOS

Introduction, embedded system vs General computing system, classification and applications, Typical Embedded System- memory management, Firmware,

2. COMMUNICATION STANDARDS AND REAL TIME OPERATING SYSTEM

Explain about SPI, I2C, UART communication protocols- Operating System Basics - Compare general OS and RTOS-Explain Real Time Operating System -List the characteristics of RTOS- Explain Tasks, Process and Threads -Explain task management and scheduling -Explain resource allocation and interrupt handling-Define Multi Processing and Multi Tasking

3. ARM CORTEX M3 ARCHITECTURE

List ARM cortex families-Compare different types of ARM cortex series- Features and applications of ARM cortex M3- architecture of ARM cortex M3- general purpose and special purpose registers of ARM cortex M3- ARM cortex M3 processor operating modes with switching diagrams- interrupts in ARM cortex M3-Interrupt Vector controller of ARM cortex M3-handling of exceptions and interrupts of ARM cortex M3-Define interrupts tail chaining in ARM-system stack architecture of ARM cortex M3-Explain about reset sequence in ARM cortex M3-Explain about pipeline architecture and data path of ARM cortex M3-Define Memory endianness in ARM cortex M3 -Define bit banding in ARM cortex processor -Explain about memory address mapping of ARM cortex M3

4. ARM - INSTRUCTION SET AND PROGRAMMING

ARM Instruction set basics, data processing instructions, memory access instructions, Multiply and divide instructions, bit field instructions, branch and control instructions.ARM programming

5. ARM INTERFACING

I/O interfacing – Fundamentals, GPIO interfacing-Explain about ADC and DAC interfacing and their usage and applications (Voltage measurement, sinewave generation)-Explain about ARM peripherals: i) Timer ii) Watchdog timer iii) Sys Tick iv) PWM v)Internal RTC Interfacing LEDs and switches, interfacing seven segment display, keypad interfacing and LCD interfacing.

Reference Books:

1. Joseph Yiu, "The Definitive Guide to ARM Cortex-M3 and Cortex-M4 Processors", Elsevier, 3rd Edition, 2014.
2. Trevor Martin, "The Designer's Guide to the Cortex-M Processor Family", 2th edition, Elsevier 2016.

3. Muhammad Tahir and Kashif Javed, "ARM Microprocessor Systems - Cortex-M Architecture, Programming, and Interfacing", CRC Press, 2017.
4. Joseph Yiu," The Definitive Guide to ARM Cortex" Prentice Hall, 3rd Edition, Elsevier 2010.
5. Jonathan W. Valvano, "Embedded Systems: Real-Time Interfacing to Arm Cortex-M Microcontrollers", Volume-2, 4th edition, 2014.
6. James A. Langbridge, "Professional Embedded Arm Development", John Wiley & Sons, 2014
7. Cortex -M3 Technical Reference Manual
8. Dr. Alexander G. Dean, "Embedded Systems Fundamentals with Arm Cortex-M based Microcontrollers: A Practical Approach in English", Published by Arm Education Media
9. Andrew Sloss, Dominic Symes and Chris Wright, "ARM System Developer's Guide", Elsevier India, 1st Edition.

BLUE PRINT

SI No	Unit Title	No of Periods	Weightage Allotted	Weightage of Marks		COs mapped
				No of Essay Questions	No of Short answer Questions	
1	Introduction to Embedded systems	10	16	1	2	CO1
2	Communication Standards And Real Time Operating System	15	26	2	2	CO2
3	ARM Cortex M3 Architecture	15	26	2	2	CO3
4	ARM - Instruction set and programming	15	26	2	2	CO4
5	ARM interfacing	10	16	1	2	CO5
		75	110	80	30	

Table specifying the scope of syllabus to be covered for Unit Tests

Unit Test	Learning outcomes to be covered
Unit Test-I	From 1.1 to 3.8
Unit Test-II	From 3.9 to 5.7

(Model Paper)

C –23, EC -502

State Board of Technical Education and Training, A. P
Diploma in Electronics and Communication Engineering (DECE)

V Semester

Subject Name: **EMBEDDED SYSTEMS**

Sub Code: **EC - 502**

Time: 90 minutes

Unit Test I

Max.Marks:40

Part-A

16Marks

Instructions: (1) Answer **all** questions.
(2) First question carries **four** marks, each question of remaining carries **three** marks

1. Fill the following blanks with one word
 - a) RISC stands for _____ (CO1)
 - b) CISC stands for _____ (CO1)
 - c) RTOS stands for _____ (CO2)
 - d) ARM stands for _____ (CO3)
2. Define Embedded System (CO 1)
3. State the features of CISC architecture (CO 1)
4. List the characteristics of RTOS (CO 2)
5. List ARM cortex families (CO 3)

Part-B

3×8=24

Instructions: (1) Answer **all** questions.
(2) Each question carries **eight** marks
(3) Answer should be comprehensive and the criterion for valuation is the content but not the length of the answer.

6. (a) Draw and explain the general block diagram of an embedded system (CO1)
or
(b) Explain Core of the Embedded System (CO1)
7. (a) Explain Real Time Operating System (CO2)
or
(b) Explain task management and scheduling (CO2)
8. (a) Draw and explain the architecture of ARM cortex M3 (CO3)
or
(b) Explain ARM cortex M3 processor operating modes with switching diagrams (CO3)

-oOo-

(Model Paper)

C –23, EC -502

State Board of Technical Education and Training, A. P
Diploma in Electronics and Communication Engineering (DECE)

V Semester

Subject Name: **EMBEDDED SYSTEMS**

Sub Code: **EC - 502**

Time: 90 minutes

Unit Test II

Max.Marks:40

Part-A

16Marks

Instructions: (1) Answer **all** questions.
(2) First question carries **four** marks, each question of remaining carries **three** marks

1. Fill the following blanks with one word
 - a) Interrupt means _____ (CO3)
 - b) Write any one data processing instruction of ARM CORTEX M3 microcontroller (CO4)
 - c) Write any one memory access instruction of ARM CORTEX M3 microcontroller (CO4)
 - d) GPIO stands for _____ (CO5)
2. Define Interrupt (CO3)
3. Define exception (CO3)
4. Draw the generalized instruction format of ARM cortex M3 (CO4)
5. Draw the pin diagram of seven segment display (common cathode) (CO 5)

Part-B

3×8=24

Instructions: (1) Answer **all** questions.
(2) Each question carries **eight** marks
(3) Answer should be comprehensive and the criterion for valuation is the content but not the length of the answer.

6. (a) Explain about system stack architecture of ARM cortex M3 (CO3)
or
(b) Explain about pipeline architecture and data path of ARM cortex M3 (CO3)
7. (a) Explain the multiply and divide instructions of ARM cortex M3 (CO4)
or
(b) Explain the bit field instructions of ARM cortex M3 (CO4)
8. (a) Explain about GPIO interfacing of ARM cortex M3 (CO5)
or
(b) Explain about Interfacing LEDs and switches of ARM cortex M3 (CO5)

-oOo-

MODEL PAPER
BOARD DIPLOMA EXAMINATIONS
V SEMESTER
Sub Code: C-23, EC – 502
Subject Name: EMBEDDED SYSTEMS
SEMESTER END EXAMINATION

TIME: 3 HOURS

MAX MARKS:80

Part-A

10×3=30

Instructions: (1) Answer **all** questions.
(2) Each question carries **three** marks
(3) Answer should be brief and straight to the point and shall not exceed five simple sentences.

1. Define Embedded System (CO1)
2. State the features of CISC architecture (CO1)
3. List the characteristics of RTOS (CO2)
4. List the features of RTOS (CO2)
5. Define Interrupt (CO3)
6. Define exception (CO3)
7. Draw the generalized instruction format of ARM cortex M3 (CO4)
8. Classify the instruction set of ARM cortex M3 (CO4)
9. Draw the pin diagram of seven segment display (common cathode) (CO5)
10. State the function of different push button switches (CO5)

Part-B

5×10=50

Instructions: (1) Answer **any Five** questions.
(2) Each question carries **TEN** marks
(3) Answer should be comprehensive and the criterion for valuation is the content but not the length of the answer.

11. Draw and explain the general block diagram of an embedded system (CO1)
12. Explain Real Time Operating System (CO2)
13. Explain task management and scheduling (CO2)
14. Draw and explain the architecture of ARM cortex M3 (CO3)
15. Explain ARM cortex M3 processor operating modes with switching diagrams (CO3)
16. Explain the multiply and divide instructions of ARM cortex M3 (CO4)
17. Explain the bit field instructions of ARM cortex M3 (CO4)
18. Explain about GPIO interfacing of ARM cortex M3 (CO5)

-oOo-

OPTICAL & MOBILE COMMUNICATIONS

Course Code	Course title	No of periods/week	Total no of periods	Marks for FA	Marks for SA
EC-503	OPTICAL & MOBILE COMMUNICATIONS	05	75	20	80

S No	Unit Title	No. of Periods	COs Mapped
1	Overview of Fibre Optic Communication	10	CO1
2	Fibre Optic components and Devices	15	CO2
3	Cellular system design fundamentals	12	CO3
4	Digital Cellular Mobile System and Multiplexing Techniques	20	CO4
5	Advanced Concepts in Digital Cellular Mobile system	18	CO5
Total		75	

Course Objectives	1. To familiarize the concepts of Fiber optic, Telephony and Cellular communication systems.
	2. To equip with various issues related to Fiber optic, Telephony and Cellular communication systems.
	3. To learn the practical importance and applications of Fiber optic, Telephony and Cellular communication systems.

CO No	COURSE OUTCOMES	
CO1	EC-503.1	Describe fiber optic communication techniques.
CO2	EC-503.2	Describe fiber optic components and devices

CO3	EC-503.3	Analyze the cellular system design
CO4	EC-503.4	Interpret Digital cellular systems and multiplexing Techniques
CO5	EC-503.5	Describe the Advanced Digital cellular mobile systems

CO-PO/PSO MATRIX

CO No	PO1	PO2	PO3	PO4	PO5	PO6	PO7	PSO1	PSO2	PSO3
EC-503.1	3	3	1		2			3		2
EC-503.2	3	3	1		2		2	3	2	2
EC-503.3	3	3	3	2	3		2	3	2	2
EC-503.4	3	3	3	2	3		2	3	2	2
EC-503.5	3	3	3	2	3		3	3	3	2
Average	3	3	2.2	2	2.6		2.25	3	2.25	2

3=strongly mapped 2=moderately mapped 1=slightly mapped

LEARNING OUTCOMES

1.0 Over View of Fibre Optic Communication

- 1.1 State the advantages of lightwave communication system over EM wave systems.
- 1.2 Explain the structure of optical fibre
- 1.3 Classify optical fibres based on refractive index profile
- 1.4 List the types of fibres based on core diameter
- 1.5 Define Single mode fibre (SMF) and multimode fibre (MMF)
- 1.6 Define Snell's law in optics
- 1.7 Explain light wave propagation in OFC
- 1.8 Define acceptance angle and Cone of acceptance.
- 1.9 Define numerical aperture (NA)
- 1.10 Derive the expression for NA interms of refractive **indices** of core and cladding

2.0 Fibre Optic Components and Devices

- 2.1 List various fibre optic components
- 2.2 State the need of splicing in optical fibres
- 2.3 State the need for optical coupler/splitter
- 2.4 List two types of sources used in OFC
- 2.5 List the salient features of an optical source
- 2.6 List two types of detectors used in OFC
- 2.7 List the salient features of an optical detector
- 2.8 State the principle of LASER
- 2.9 Explain the construction and working of LASER source (Fabry Perot Resonator Cavity)
- 2.10 Explain the construction and working of Avalench Photo Diode (Reach Through APD)
- 2.11 Draw the block diagram of fibre optic communication system and explain each block
- 2.12 Explain intrinsic and extrinsic losses in optical fibres
- 2.13 Classify different types of dispersion losses occur in optical fibres.
- 2.14 State the limitations of TDM in fiber optic communications
- 2.15 State the need for WDM in fibre optic communication
- 2.16 Draw the block diagram of WDM system and explain
- 2.17 Draw the block diagram of DWDM system and explain

3.0 Cellular system design fundamentals

- 3.1 List the limitations of conventional mobile phone system.
- 3.2 Explain the evolution of cellular mobile communication system.
- 3.3 Draw the block diagram of a basic cellular system
- 3.4 Define the terms mobile station and base station
- 3.5 State the functions of Mobile Switching Centre (MSC)
- 3.6 Define forward and reverse channels in mobile communication
- 3.7 Define voice and control channels in mobile communication
- 3.8 Explain the process of call progress in a cellular telephone system
- 3.9 State the need for hexagonal cell site
- 3.10 Explain the concept of Frequency reuse
- 3.11 Define the terms cell and cluster related to Mobile communications
- 3.12 Define Co-Channel Reuse ratio and obtain its relation with cluster size.
- 3.13 Explain the capacity of a cellular system and derive its expression.
- 3.14 Define Hand-off in mobile communication
- 3.15 Explain the radio subsystem of analog cellular system (AMPS)
- 3.16 List the drawbacks of analog cellular system.

4.0 Digital Cellular Mobile System and Multiple access Techniques

- 4.1 List the features of digital cellular system.
- 4.2 Explain the frequency spectrum of Global system for mobile communication (GSM) system
- 4.3 Explain the architecture of GSM.
- 4.4 List various interfaces in GSM architecture
- 4.5 List the service and security aspects of GSM.
- 4.6 Explain the authentication and encryption process used in GSM security.
- 4.7 List the advantages of GSM
- 4.8 List the draw backs of GSM system.
- 4.9 State the need for multiple access techniques
- 4.10 List the three types of multiple access techniques.
- 4.11 List the features of FDMA and TDMA
- 4.12 Explain the frame structure of a TDMA
- 4.13 Explain the concept of spread spectrum technique
- 4.14 Explain CDMA and list its features
- 4.15 Compare FDMA, TDMA and CDMA
- 4.16 Explain the concept of OFDM

5.0 Advanced Concepts in Digital Cellular Mobile system

- 5.1 List the features of GPRS and EDGE systems
- 5.2 Compare the features of GSM, GPRS and EDGE systems
- 5.3 List the salient features of 3G system
- 5.4 List the advantages of 3G over earlier versions
- 5.5 Explain the architecture of 3G Cellular System (UMTS)
- 5.6 Explain briefly about soft-handoff and power control in CDMA
- 5.7 Distinguish bwtween hard-off and soft-hand-off.
- 5.8 List the salient features of 4G Cellular system
- 5.9 Explain the VoLTE architecture of IP Multimedia Subsystem (IMS)
- 5.10 List different IMS applications
- 5.11 List the salient features of 5G Cellular System
- 5.12 Explain the architecture of 5G Cellular system

- 5.13 Explain about 5G NR technology
- 5.14 List the applications of 5G technology

COURSE CONTENTS:

1. Overview of Fibre Optic Communication

Advantages of Light wave communication system over EM wave systems- structure of optical fibre- Classification of optical fibres based on refractive index profile- types of fibres based on core diameter - Single mode(SMF) and Multimode fibre (MMF)-Snell's law in optics -light wave propagation in OFC-acceptance angle and Cone of acceptance-numerical aperture (NA)-intrinsic and extrinsic losses-Classification of different types of dispersion losses occur in optical fibres- WDM in fibre optic communication- block diagram of WDM system

2.Fibre Optic Components and Devices

List of fibre optic components- function of splice in optical fibres-need for optical coupler/splitter-sources used in OFC- two types of detectors used in OFC- feature of an optical detector-principle of LASER-construction and working of LASER source- construction and working of APD- block diagram of fibre optic communication system and explain each block.

3. Cellular system design fundamentals

Conventional mobile phone system-Evolution of cellular mobile communication system- mobile station and base station-functions of Mobile switching centre (MSC)- voice and control channels in mobile communication-Block diagram of a basic cellular system- call progress in a cellular telephone system- hexagonal cell site- Frequency reuse-Cell and cluster- Cluster size and co-channel reuse ratio - capacity of a cellular system-Hand-off in mobile communication-drawbacks of analog cellular system

4. Digital Cellular mobile system and Multiplexing Techniques

-need for multiple access techniques-three types of multiple access techniques TDMA, FDMA and CDMA -Compare FDMA, TDMA and CDMA-OFDM-Features of digital cellular system- Global system for mobile communication (GSM) with block diagram-interfaces in GSM architecture-service and security aspects of GSM-advantages of GSM-draw backs of GSM system

5. Advanced Digital Cellular mobile system

GPRS and EDGE-salient features of 3G system-advantages of 3G over earlier versions-architecture of 3G cellular system – soft hand-off – power control in CDMA -basic concepts of 4G aspects –VoLTE architecture of IP Multimedia Subsystem (IMS) - IMS applications-Salient features of 5G-architecture of 5G

REFERENCE BOOKS

1. Raj Pandya, Mobile and Personal communication systems and services,PHI
2. Theodore S. Rappaport, PEARSON Wireless communications-Principles and practice
3. Willium C. Y. Lee Mobile Cellular Telecommunications-Analog and Digital systems, McGrawHill
4. Jochen Schiller Mobile Communications ,PEARSON
5. GerdKeise,OpticalFiberCommunications
6. Anuradha De Optical fiber and Laser- Principles and applications, New Agepublications
7. John M. Senior Optical fiber communications-Principles and practice, PearsonPublications

8. S.C.Gupta, 2004 Optical Fiber Communications and Its Applications ,PHI.

BLUE PRINT:

SI No	Unit Title	No of Periods	Weightage Allotted	Weightage of Marks		COs mapped
				No of Essay Questions	No of Short answer Questions	
1	Over View of Fibre Optic Communication	10	16	1	2	CO1
2	Fibre Optic components and Devices	15	21	1.5	2	CO2
3	Cellular system design fundamentals	12	26	2	2	CO3
4	Digital Cellular mobile system and Multiplexing Techniques	20	26	2	2	CO4
5	Advanced Digital Cellular mobile system	18	21	1.5	2	CO5
		75	110	80	30	

Table specifying the scope of syllabus to be covered for Unit Tests

Unit Test	Learning outcomes to be covered
Unit Test-I	From 1.1 to 3.8
Unit Test-II	From 3.9 to 5.12

(Model Paper)

C –23, EC -503

State Board of Technical Education and Training, A. P
Diploma in Electronics and Communication Engineering (DECE)

V Semester

Subject Name: **Optical & Mobile Communications**

Sub Code: **EC - 503**

Time : 90 minutes

Unit Test I

Max.Marks:40

Part-A

16Marks

Instructions: (1) Answer **all** questions.
(2) First question carries **four** marks, each question of remaining carries **three** marks

1. Answer the following questions with one word
 - a) Write Full form of TIR (CO1)
 - b) Write full form of WDM (CO2)
 - c) Write full form of LASER (CO2)
 - d) Write full form of FCC (CO3)
2. Classify fibers based on refractive index profile and core diameter. (CO1)
3. Define critical angle and numerical aperture. (CO1)
4. List various fiber optic components. (CO2)
5. Write the need Hexagonal Cell Site. (CO3)

Part-B

3×8=24

Instructions: (1) Answer **all** questions.
(2) Each question carries **eight** marks
(3) Answer should be comprehensive and the criterion for valuation is the content but not the length of the answer.

6. (a) Explain the principle of Light propagation through Optical fiber (CO1)
or
(b) Explain structure of optical fiber and classify them based on RI profile (CO1)
7. (a) Draw the block diagram of fiber optic communication system and explain. (CO2)
or

- (b) Explain the construction and working of LASER source. (CO2)
8. (a) Explain the evolution of cellular communication in detail. (CO3)
- or
- (b) Derive the expression for cellular capacity. (CO3)

o0o-
(Model Paper)

C -23, EC -503

State Board of Technical Education and Training, A. P
Diploma in Electronics and Communication Engineering (DECE)

V Semester

Subject Name: **Optical & Mobile Communications**

Sub Code: **EC - 503**

Time : 90 minutes

Unit Test II

Max.Marks:40

Part-A

16Marks

Instructions: (1) Answer **all** questions.
(2) First question carries **four** marks, each question of remaining carries **three** marks

1. Answer the following questions with one word
 - a) List any one type of multiple access techniques (CO3)
 - b) Write any one application of IP Multimedia Subsystem (CO5)
 - c) Write full form of GPRS (CO5)
 - d) Write full form of GPS (CO5)
2. Define the terms Cell station and Cluster. (CO3)
3. Define capacity of cellular system (CO3)
4. List the various interfaces of GSM (CO4)
5. List the salient features of 5G system (CO5)

Part-B

3×8=24

Instructions: (1) Answer **all** questions.
(2) Each question carries **eight** marks
(3) Answer should be comprehensive and the criterion for valuation is the content but not the length of the answer.

6. (a) Explain the Concept of Spread Spectrum technique (CO3)
- or
- (b) Explain the frame structure of TDM. (CO3)
7. (a) Draw the block diagram of GSM architecture and explain. (CO4)
- or
- (b) Explain process of data encryption in GSM. (CO4)

8. (a) Explain the architecture of 5G cellular system. (CO5)
or
(b) Compare the features of GSM, GPRS and EDGE systems. (CO5)

o0o-

MODEL PAPER
BOARD DIPLOMA EXAMINATIONS
C-23, EC-503, OPTICAL & MOBILE COMMUNICATIONS
V SEMESTER
SEMESTER END EXAMINATION

TIME:3 HOURS

MAX MARKS:80

Part-A

10×3=30

Instructions: (1) Answer **all** questions.
(2) Each question carries **three** marks
(3) Answer should be brief and straight to the point and shall not exceed five simple sentences.

1. Classify fibers based on refractive index profile and core diameter. (CO1)
2. Define critical angle and acceptance angle. (CO1)
3. Write the need for Splice and Coupler. (CO2)
4. List the salient features of optical detectors. (CO2)
5. Define the terms cell and cluster. (CO3)
6. Define handoff in mobile communication. (CO3)
7. List the applications of Spread spectrum technique. (CO4)
8. List the service aspects of GSM. (CO4)
9. Distinguish between GPRS and EDGE. (CO5)
10. List the salient features of 5G systems. (CO5)

Part-B

5×10=50

- Instructions:** (1) Answer **any Five** questions.
(2) Each question carries **10** marks
(3) Answer should be comprehensive and the criterion for valuation is the content but not the length of the answer.

11. Define Snell's law and explain the principle of light propagation through an optical fiber. (CO1)
12. Draw the structure of Fabry perot resonator cavity LASER and explain its working. (CO2)
13. Explain the process of call progress in cellular system. (CO3)
14. Define Cellular capacity and derive the relation between cellular capacity and co-channel reuse ratio (CO3)
15. Explain the concept of spread spectrum technique with block diagram (CO4)
16. Draw the block diagram of GSM architecture and explain. (CO4)
17. Draw and explain the VoLTE architecture for IMS. (CO5)
18. (a) Write short notes on various dispersions in the fiber. (5 Marks) (CO2)
(b) Explain the concepts of GPRS. (5 Marks) (CO5)

INDUSTRIAL ELECTRONICS & AUTOMATION

Course Code	Course title	No of periods/week	Total no of periods	Marks for FA	Marks for SA
EC-504	INDUSTRIAL ELECTRONICS & AUTOMATION	05	75	20	80

S No	Unit Title	No. of Periods	COs Mapped
1	Power Electronic Devices	20	CO1
2	Inverters, SMPS, UPS & Battery Management	15	CO2
3	Transducers and Ultrasonics	12	CO3
4	Control systems	13	CO4
5	PLCs and SCADA	15	CO5
	Total	75	

Course Objectives	1. To learn the principles and working of power Electronic devices, opto electronic devices, Transducers, SMPS, UPS, PLC etc..
	2. To analyze the Industrial heating, and Control systems
	3. To learn the practical importance Industrial electronic devices and circuits.

CO No		COURSE OUTCOMES
CO1	EC-504.1	Describe Various Power Electronic Devices like SCR, DIAC, TRIAC etc.
CO2	EC-504.2	Understand the principle of working of Inverters, SMPS, UPS and Battery Management
CO3	EC-504.3	Understand and use different Transducers and Ultrasonics
CO4	EC-504.4	Understand the concepts of control systems
CO5	EC-504.5	Use the concepts of PLC & SCADA for industrial applications

CO-PO/PSO MATRIX

CO No	PO1	PO2	PO3	PO4	PO5	PO6	PO7	PSO1	PSO2	PSO3
EC-504.1	3	2	2	2	2		2	3		
EC-504.2	3	2	2	2	2		2	3		
EC-504.3	3	2	3	2	3		2	3	1	2
EC-504.4	3	2	3	2	3		2	3	1	2
EC-504.5	3	2	3	3	3		3	3	3	3

Average	3	2	2.6	2.2	2.6		2.2	3	1.6	2.3
----------------	---	---	-----	-----	-----	--	-----	---	-----	-----

3=strongly mapped

2=moderately mapped

1=slightly mapped

LEARNING OUTCOMES

1.0 Power Electronic Devices

- 1.1 List different thyristor family devices.
- 1.2 Sketch the ISI circuit symbols of SCR, SCS, SBS, SUS, DIAC, TRIAC and GTO SCR
- 1.3 Explain the construction and working of SCR
- 1.4 Explain the Two-transistor model of SCR and its VI Characteristics
- 1.5 Mention the ratings of SCR
- 1.6 Explain the construction and working of GTO SCR
- 1.7 Explain construction and working of DIAC & TRIAC
- 1.8 Explain Volt-ampere characteristics of DIAC & TRIAC
- 1.9 State the different modes of TRIAC triggering.
- 1.10 Compare the features of SUS, SBS, SCS & LASCR
- 1.11 Explain the construction and working of UJT
- 1.12 Define intrinsic stand-off ratio of UJT
- 1.13 Explain negative resistance region of UJT
- 1.14 Explain SCR triggering using UJT
- 1.15 Explain about speed control of DC motor using SCR
- 1.16 List the applications of DIAC, TRIAC & SCR

2.0 Inverters, SMPS, UPS & Battery Management

- 2.1 State the need of inverters
- 2.2 State the principle of operation of inverter
- 2.3 Explain the working of MOSFET based Inverter circuit
- 2.4 Explain Voltage control of inverter using PWM
- 2.5 List the applications of inverters
- 2.6 Explain the working of SMPS with block diagram
- 2.7 List the applications of SMPS
- 2.8 Explain the working of Off Line UPS and Online UPS
- 2.9 List the applications of UPS
- 2.10 List various Batteries used in Industries and e-vehicles
- 2.11 State the importance of Battery Management
- 2.12 Explain about the Battery management concepts used in e-vehicles
- 2.13 List various methods used for charging for Battery
- 2.14 Explain the charging circuit for Battery
- 2.15 Explain the various stages of charging Battery
- 2.16 Explain the concept of short circuit protection of Battery
- 2.17 Explain the concept of Overload protection of Battery
- 2.18 Explain the the concept of deep discharge protection of Battery
- 2.19 Explain the the concept of over heat protection of Battery

3.0 Transducers and Ultrasonics

- 3.1 Define the term transducer

- 3.2 Classify different electrical/electronic transducers on the basis of principle of operation and applications.
- 3.3 List different Resistive, Inductive and Capacitive transducers
- 3.4 Explain the working principle, construction and applications of resistance strain gauge.
- 3.5 Explain the working principle, construction and applications of potentiometric transducer.
- 3.6 Explain the construction and working of LVDT
- 3.7 State the concept of piezo-electric effect
- 3.8 Explain the construction and working of Piezo-electric transducer
- 3.9 Explain the construction and working of Thermocouple transducer
- 3.10 Explain the working principle of Accelerometer
- 3.11 Define the term ultrasonics
- 3.12 State the concept of magnetostriction effect
- 3.13 Explain the construction and working of magnetostrictionultrasonic generator
- 3.14 Explain the construction and working of piezoelectric ultrasonic generator
- 3.15 List the applications of ultrasonics
- 3.16 Explain the construction and working of pulsed-echo ultrasonic flaw detector

4.0 Control Systems

- 4.1. Define system and Control system.
- 4.2. Classify control systems
- 4.3. Explain the basic block diagram of control system
- 4.4. Explain an open loop control system.
- 4.5. Give examples for open loop control system.
- 4.6. Give three merits and demerits of open loop control.
- 4.7. Explain the closed loop system with the help of a block diagram.
- 4.8. Give Examples for closed loop system
- 4.9. Compare Open loop and closed loop control systems.
- 4.10. Define Transfer function
- 4.11. Explain block diagram reduction techniques.
- 4.12. Solve simple problems using the above techniques

5.0 PLCs & SCADA Programming

- 5.1. Explain the need for PLC
- 5.2. Explain the basic principle of PLCs.
- 5.3. List out the advantages and disadvantages of PLC's.
- 5.4. Draw and explain the functional block diagram of PLC.
- 5.5. Explain the Ladder diagrams and sequence listing.
- 5.6. Draw ladder diagram for OR logic and write the PLC code.
- 5.7. Draw ladder diagram for AND logic and write the PLC code.
- 5.8. Draw ladder diagram for XOR logic and write the PLC code
- 5.9. Explain the importance of PLC timers with examples.
- 5.10. Explain the importance of PLC counters with examples.
- 5.11. List the features of popular PLCs like Siemens , Allenbradly .
- 5.12. List any 4 applications of PLCS in the industry.
- 5.13. Mention the importance of SCADA.
- 5.14. Explain a typical SCADA system.
- 5.15. List the applications of SCADA.

COURSE CONTENTS

1. Power Electronic Devices

Thyristor family devices- ISI circuit symbols - working of SCR-Two-transistor model of SCR and its VI Characteristics-ratings of SCR- working of GTO SCR- working of DIAC & TRIAC- Volt-ampere characteristics of DIAC & TRIAC-modes of TRIAC triggering-SUS, SBS, SCS & LASCR -construction and working of UJT-intrinsic stand-off ratio of UJT-negative resistance region of UJT-SCR triggering using UJT, Speed control of DC motor using SCR,applications of SCR,TRIAC and DIAC.

2. Inverters, SMPS, UPS & Battery Management

Need of inverters -MOSFET based Inverter circuit- PWM Voltage control of Inverter -SMPS with block diagram-applications of SMPS -Off Line UPS and Online UPS-Different Batteries used in Industry and e-vehicles- Battery charging & Battery management concepts

3. Transducers & Ultrasonics

Introduction, classification of transducers, Resistive, Inductive, capacitive transducers, Strain gauge, Potentiometric transducer, LVDT. Piezoelectric effect, Piezoelectric transducer, Thermocouple transducer, accelerometers,Ultrasonic generation –Pulsed echo ultrasonic flaw detector

4. Control systems

Definition of system and Control system-open loop control system-merits and demerits of open loop control-closed loop system-comparison between open loop and closed loop control systems-Transfer function

5 PLC and SCADA

Need for PLC- principle of PLCs- advantages and disadvantages of PLC's- functional block diagram of PLC- Ladder diagrams and sequence listing- ladder diagram for OR, AND, XOR logic and PLC code-importance of PLC timers with examples- importance of PLC counters with examples-features of popular PLCs like Siemens , Allenbradly- applications of PLCs- importance of SCADA-typical SCADA system- applications of SCADA.

.REFERENCE BOOKS

1. Bimbhra P.S, Power Electronics, Khanna Publishers Delhi
2. P.C.Sen.,PowerElectronics, McGraw Hill Education, India
3. S.K.Bhattacharya, S.Chatterjee, Industrial Electronics andControl, McGraw Hill Education, India
4. User manuals of PLCs,SCADA
5. Nagarath&Gopal, Control system Engineering, 5th edition, New age international Publishers
6. Muhammad H. Rashid ,Power electronics (Devices , circuits & applications), 4th edition, PERSON
7. V.R Moorthi, Power electronics : Devices , circuits & Industrial applications, OXFORD Publications
8. PLCs &SCADA : Theory and Practice by Rajesh Mehra, Vikrant Vij- Laxmi Publications

BLUE PRINT

SI No	Unit Title	No of Periods	Weightage Allotted	Weightage of Marks		COs mapped
				No of Essay Questions	No of Short answer Questions	
1	Power Electronic Devices	20	26	2	2	CO1
2	Inverters, SMPS, UPS & Battery Management	15	26	2	2	CO2
3	Transducers and Ultrasonics	12	16	1	2	CO3
4	Control systems	13	16	1	2	CO4
5	PLCs and SCADA	15	26	2	2	CO5
		75	110	80	30	

Table specifying the scope of syllabus to be covered for Unit Tests

Unit Test	Learning outcomes to be covered
Unit Test-I	From 1.1 to 2.12
Unit Test-II	From 3.1 to 5.13

(Model Paper)
State Board of Technical Education and Training, A. P
Diploma in Electronics and Communication Engineering (DECE)
V Semester

C –20, EC -504

Subject Name: Industrial Electronics

Sub Code: EC - 504

Time : 90 minutes

Unit Test I

Max.Marks:40

Part-A

16Marks

Instructions: (1) Answer **all** questions.
(2) First question carries **four**marks, each question of remaining carries **three** marks

1. Draw the circuit symbols of following components
 - a) GTO SCR (CO1)
 - b) SCS (CO1)
 - c) LASCR (CO1)
 - d) SUS (CO1)
2. Define intrinsic stand-off ratio of UJT (CO1)
3. Draw VI characteristics of DIAC (CO1)
4. State the need of inverters (CO2)
5. List the applications of SMPS (CO2)

Part-B

3×8=24

Instructions: (1) Answer **all** questions.
(2) Each question carries **eight** marks
(3) Answer should be comprehensive and the criterion for valuation is the content but not the length of the answer.

6. (a) Explain the triggering of TRIAC in different modes (CO1)
or
(b) Explain about speed control of DC motor using SCR (CO1)
7. (a) Explain the construction and working of UJT (CO1)
or
(b) Explain the working of MOSFET based Inverter circuit. (CO2)
8. (a) Explain the working of SMPS with block diagram (CO2)
or
(b) Explain the concept of deep discharge protection of Battery (CO2)

-o0o-

(Model Paper)

C –20, EC -504

State Board of Technical Education and Training, A. P

Diploma in Electronics and Communication Engineering (DECE)

V Semester

Subject Name: Industrial Electronics

Sub Code: EC - 504

Time : 90 minutes

Unit Test II

Max.Marks:40

Part-A

16Marks

Instructions: (1) Answer **all** questions.
(2) First question carries **four**marks, each question of remaining carries **three** marks

1. Draw the circuit symbols of following components
 - a) LVDT Stands for_____ (CO3)
 - b) The control system without feedback is called _____ (CO4)
 - c) PLC stands for_____ (CO5)
 - d) SCADA stands for_____ (CO5)
2. Define the term transducer. (CO3)
3. Define the term Transfer function in the context of control systems (CO4)
4. Compare open loop and closed loop control systems. (CO4)
5. State the need for PLC (CO5)

Part-B

3×8=24

Instructions: (1) Answer **all** questions.
(2) Each question carries **eight** marks
(3) Answer should be comprehensive and the criterion for valuation is the content but not the length of the answer.

6. (a) Explain the working principle, construction and applications of resistance strain gauge. (CO3)
or
(b) Explain the working principle of accelerometer. (CO3)
7. (a) Explain the closed loop system with the help of a block diagram. (CO4)
or
(b) Explain block diagram reduction techniques. (CO4)
8. (a) Draw and explain the functional block diagram of PLC. (CO5)
or
(b) Explain a typical SCADA system. (CO5)

-oOo-

MODEL PAPER
BOARD DIPLOMA EXAMINATIONS
C-23, EC-504, INDUSTRIAL ELECTRONICS

**V SEMESTER
SEMESTER END EXAMINATION**

TIME:3 HOURS

MAX MARKS:80

Part-A

10×3=30

Instructions: (1) Answer **all** questions.
(2) Each question carries **three** marks
(3) Answer should be brief and straight to the point and shall not exceed five simple sentences.

1. Define intrinsic stand-off ratio of UJT (CO1)
2. Draw VI characteristics of DIAC (CO1)
3. State the need of inverters (CO2)
4. List the applications of SMPS (CO2)
5. Define the term ultrasonics (CO3)
6. State the concept of magnetostriction effect (CO3)
7. Define the term Transfer function in the context of control systems (CO4)
8. Compare open loop and closed loop control systems. (CO4)
9. State the need for PLC (CO5)
10. List any three applications of PLCS in the industry (CO5)

Part-B

5×10=50

Instructions: (1) Answer **all** questions.
(2) Each question carries TEN marks
(3) Answer should be comprehensive and the criterion for valuation is the content but not the length of the answer.

11. Explain the triggering of TRIAC in different modes (CO1)
12. Explain about speed control of DC motor using SCR (CO1)
13. Explain the working of SMPS with block diagram (CO2)
14. Explain the concept of deep discharge protection of Battery (CO2)
15. Explain the working principle, construction and applications of resistance strain gauge. (CO3)
16. Explain the working principle of accelerometer. (CO3)
17. Explain the closed loop system with the help of a block diagram. (CO4)
18. Explain a typical SCADA system. (CO5)

-oOo-

DATA COMMUNICATION AND COMPUTER NETWORKS

Course Code	Course title	No of periods/week	Total no of periods	Marks for FA	Marks for SA
EC-505	Data Communication and Computer Networks	05	75	20	80

S No	Unit Title	No. of Periods	COs Mapped
1	Basics of Data communication and OSI Reference Model	13	CO1
2	Physical Layer and Data Link Layer	15	CO2
3	Network Layer, Transport Layer and Application Layer	28	CO3
4	Wireless Network Protocols	12	CO4
5	Cyber Security	7	CO5
	Total	75	

Course Objectives
1. To familiarize with Basics of Data Communication and the layers of OSI Model
2. To analyze various wireless network protocols
3. To analyze wireless Security protocols

CO No	COURSE OUTCOMES
CO1	EC-505.1 Describe data communication and OSI model
CO2	EC-505.2 Describe Physical and data link layers
CO3	EC-505.3 Analyze network layers
CO4	EC-505.4 Describe Wireless Network Protocols
CO5	EC-505.5 Describe Cyber Security

CO-PO/PSO MATRIX

CO No	PO1	PO2	PO3	PO4	PO5	PO6	PO7	PSO1	PSO2	PSO3
EC-505.1	3	2	2		3		3	3	1	
EC-505.2	3	2	2	3	3		3	3	3	3
EC-505.3	3	3	1		3		1	3		1
EC-505.4	3	3	2		3		1	3		1
EC-505.5	3	3	2	3	3		3	3	3	3
Average	3	2.6	1.8	3	3		2.2	3	2.3	2

3=strongly mapped 2=moderately mapped 1=slightly mapped

LEARNING OUTCOMES:

1.0 Basics of Data communication and OSI Reference Model

- 1.1 Define data and information
- 1.2 Define data communication
- 1.3 State the characteristics of data communication
- 1.4 State the components of data communication
- 1.5 Explain briefly about data representation of numbers, text, images, audio and video
- 1.6 Define the different modes of data flow (simplex, half duplex and full duplex)
- 1.7 Distinguish between serial communication and parallel communication
- 1.8 Define computer network and state its use
- 1.9 State the need for data communication networking.
- 1.10 Define network topology
- 1.11 List different network topologies
- 1.12 Explain Bus, Star, Ring network topologies
- 1.13 Compare the performances of the above three topologies.
- 1.14 Draw the ISO: OSI 7 layer architecture and State the functions of each layer.
- 1.15 Draw TCP/IP reference model and State the functions of each layer
- 1.16 Compare ISO :OSI 7 layer model with TCP/IP reference model

2.0 Physical Layer and Data Link Layer

a) Physical Layer:

- 2.1 List the different types of physical transmission media used in networking
- 2.2 Explain the cross sectional diagrams of UTP, STP, Coaxial and Fiber optic cables and their use in networking.
- 2.3 List the three types of switching techniques used in networking
- 2.4 Explain circuit switching and packet switching
- 2.5 Define virtual circuit and datagram approaches in packet switching
- 2.6 State the use of repeater/ hub

b) Data Link Layer:

- 2.7 Define the word *protocol* used in computer networks
- 2.8 State the need for protocols in computer networks.
- 2.9 Explain CSMA/CD, CSMA/CA
- 2.10 Explain Ethernet LAN
- 2.11 Give the frame format for Ethernet and State the different fields in it.
- 2.12 Explain the working of token ring network

3.0 Network Layer, Transport Layer and Application Layer

a) Network Layer:

- 3.1 Define the terms Internet and Intranet.
- 3.2 Explain classful addressing in IPv4.
- 3.3 Explain classless addressing (CIDR) in IPv4.
- 3.4 State the use of routers in networking
- 3.5 Explain the concept of routers and routing packets in computer networks
- 3.6 Distinguish among cut through, store-and-forward and adaptive switch mechanisms.
- 3.7 Explain the packet transfer mechanism using routers and IP address.

b) Transport Layer

- 3.8 List the features of Transmission Control Protocol (TCP)
- 3.9 Explain the flow control in TCP
- 3.10 Explain error control in TCP
- 3.11 Explain the connectivity of systems using TCP (Three way hand shake)
- 3.12 Explain end-to-end connectivity in TCP using ports and sockets.
- 3.13 Describe the features of User Datagram Protocol (UDP)
- 3.14 Compare the features of TCP and UDP
- 3.15 State the use of Gateway Router.

c) Application Layer:

- 3.16 Mention the role of DNS server
- 3.17 Explain how email is transferred
- 3.18 Discuss POP server and SMTP server
- 3.19 Explain file transfer operation using FTP
- 3.20 Explain the working of Web server
- 3.21 Describe the web browser architecture
- 3.22 Explain the internal architecture of ISP
- 3.23 Write the purpose of proxy server
- 3.24 Explain remote login

4.0 Wireless Network Protocols

- 4.1 Define the term Wireless LAN.
- 4.2 List the advantages of WLAN.
- 4.3 Explain the topology of wireless LAN and its frame format (IEEE 802.11)
- 4.4 State the features of Bluetooth technology.
- 4.5 State the applications of Bluetooth technology.
- 4.6 Compare the features of IEEE 802.11n and IEEE 802.11b.
- 4.7 State the necessity of Low-rate WPAN(IEEE 802.15.4)
- 4.8 Explain the Low-WPAN (IEEE 802.15.4) device architecture.
- 4.9 Explain the features of Zigbee Technology and its topologies.
- 4.10 Explain the architecture of LoWPAN and its protocol stack.
- 4.11 State the features of LoRaWAN
- 4.12 List the applications of LoRaWAN
- 4.13 Differentiate between WiFi and LoRaWAN
- 4.14 Explain the architecture of LoRaWAN
- 4.15 State the features and applications of Sigfox

5.0 Cyber Security

- 5.1 Define the term Cyber Security.
- 5.2 State the necessity of Cyber Security.
- 5.3 State the fundamentals of Cyber Security.
- 5.4 List the layers of Cyber Security.
- 5.5 Explain the active and passive attacks in Cyber attacks.
- 5.6 Explain the functions of firewall
- 5.7 Define the terms: i) virus ii) malware iii) adware iv) trojan v) worm related to computer security
- 5.8 List the features of a typical "total security" tools

- 5.9 List different types of viruses and various ways of removing viruses
- 5.10 List any six popular Anti-Virus Software available in market

COURSE CONTENTS:

1.0 Basics of Data communication and OSI Reference Model

Need for data communication networking, network topology, different network topologies, Bus, Star, Ring network topologies, OSI 7 layer architecture- functions of each layer, TCP/IP reference model- functions of each layer

2.0 Physical Layer and Data Link Layer

a) Physical Layer:

Different physical transmission media- UTP, STP, Coaxial and Fiber optic cable, switching techniques - circuit switching, packet switching and message switching, virtual circuit and datagram approaches in packet switching, use of repeater/hub

b) Data Link Layer:

Protocol, need for protocols, need for framing, need for flow control and error control protocols, Medium access control (MAC) - its functions, CSMA/CD and CSMA/CA, Local area network - its use, Ethernet and its frame format, working of token ring network.

3.0 Network Layer, Transport Layer and Application Layer

a) Network Layer:

Internet and Intranet, classful addressing and classless addressing in IPv4, use of routers in networking, concept of routers and routing, cut through & store-and-forward and adaptive switch mechanism, packet transfer mechanism using routers and IP address.

b) Transport Layer

Features of Transmission Control Protocol (TCP), flow control in TCP, error control in TCP, connectivity of systems using TCP (Three way hand shake), end-to-end connectivity in TCP using ports and sockets, features of User Datagram Protocol (UDP), use of Gateway Router

c) Application Layer:

Role of DNS server, how email is transferred, POP server and SMTP server, FTP working of Web server, web browser architecture, internal architecture of ISP, purpose of proxy server, remote login

4. Wireless Network Protocols

Wireless Network technologies- IEEE802.11, IEEE802.11 architecture, frame format, features and applications of Bluetooth technology, Low-rate WPAN (IEEE 802.15.4) device architecture, Zigbee Technology topologies, 6LoWPAN architecture-Protocol stack.

5. Cyber Security

Basic Cyber Security Concepts, fundamentals and layers of security, Cyber attacker actions,, active attacks, passive attacks, functions of firewall, define the terms: i) virus ii) malware iii) adware iv) trojan v) worm related to computer security, List the features of a typical "total security" tools , List different types of viruses and various ways of removing viruses, List any six popular Anti-Virus Software available in market

Reference Books:

1. Ata Elahi Thomson, Network communication Technology
2. Godbole, Data Communication and Networking, TMH
3. William Stallings, Data and Computer Communications, 7th edition. PHI
4. Behrouz Forouzan, Data Communication and Networking, 3rd edition. TMH
5. Nina Godbole and Sunit Belpure, Cyber Security Understanding Cyber Crimes, Computer Forensics and Legal Perspectives, Wiley
6. B.B. Gupta, D.P. Agrawal, Haoxiang Wang, Computer and Cyber Security: Principles, Algorithm, Applications, and Perspectives, CRC Press
7. Wayne Tomasi, Introduction to data communication and networking, Pearson India Publications
8. Thomas Robertazzi, Basics of computer networking, Springer publishers

BLUE PRINT

SI No	Unit Title	No of Periods	Weightage Allotted	Weightage of Marks		COs mapped
				No of Essay Questions	No of Short answer Questions	
1	Basics of Data communication and OSI Reference Model	10	16	1	2	CO1
2	Physical Layer and Data Link Layer	15	19	1	3	CO2
3	Network Layer, Transport Layer and Application Layer	28	26	3	2	CO3
4	Wireless Network Protocols	12	26	2	1	CO4
5	Wireless Security	10	26	1	2	CO5
		75	110	80	30	

Table specifying the scope of syllabus to be covered for Unit Tests

Unit Test	Learning outcomes to be covered
Unit Test-I	From 1.1 to 3.7
Unit Test-II	From 3.7 to 5.8

(Model Paper)

C –20, EC -505

State Board of Technical Education and Training, A. P
Diploma in Electronics and Communication Engineering (DECE)
V Semester

Subject Name: Data Communication and Computer Networks

Sub Code: EC - 505

Time : 90 minutes

Unit Test I

Max.Marks:40

Part-A

16Marks

Instructions: (1) Answer **all** questions.

(2) First question carries **four** marks, each question of remaining carries **three** marks

1. a) Write any one antivirus software name available in market (CO2)
- b) What is the full form of NTFS (CO1)
- c) What is the full form of USB (CO1)
- d) What is the full form of FAT (CO1)
2. State the need for data communication networking (CO1)
3. List the three types of switching techniques used in networking (CO2)
4. State the need for protocols in computer networks. (CO2)
5. Define the terms Internet and Intranet. (CO3)

Part-B

3×8=24

Instructions: (1) Answer **all** questions.

(2) Each question carries **eight** marks

(3) Answer should be comprehensive and the criterion for valuation is the content but not the length of the answer.

6. (a) Draw the ISO: OSI 7 layer architecture and State the functions of each layer.. (CO1)
or
(b) Draw TCP/IP reference model and State the functions of each layer. (CO1)
7. (a) Explain CSMA/CD, CSMA/CA. (CO2)
or
(b). Explain the frame format for Ethernet and State the different fields in it (CO2)
8. (a) Explain classful addressing in IPv4.. (CO3)

or

(b)Distinguish among cut through, store-and-forward and adaptive switch mechanisms.(CO3)

-o0o-

(Model Paper)

C –20, EC -505

State Board of Technical Education and Training, A. P
Diploma in Electronics and Communication Engineering (DECE)
V Semester

Subject Name: Data Communication and Computer Networks

Sub Code: EC - 505

Time : 90 minutes

Unit Test II

Max.Marks:40

Part-A

16Marks

- Instructions:** (1) Answer **all** questions.
(2) First question carries **four**marks, each question of remaining carries **three** marks

1. a) What is the full form of FTP (CO3)
- b) What is the full form of UDP (CO3)
- c) What is the full form of WLAN (CO4)
- d) What is the full form of DNS (CO4)
2. Compare the features of TCP and UDP (CO3)
3. List the advantages of WLAN. (CO4)
4. State the applications of Bluetooth technology. (CO4)
5. Define the term Cyber Security. (CO5)

Part-B

3×8=24

- Instructions:** (1) Answer **all** questions.
(2) Each question carries **eight** marks
(3) Answer should be comprehensive and the criterion for valuation is the content but not the length of the answer.

6. (a) Explain the working of Web server (CO3)
or
(b) Explain the internal architecture of ISP (CO3)
7. (a) Explain the topology of wireless LAN and its frame format (IEEE 802.11) (CO4)
or
(b) Describe the features of Zigbee Technology and its topologies. (CO4)
8. (a) Explain the active and passive attacks in Cyber attacks. (CO5)
or
(b) Describe the five predominant laws in Information Technology Act, 2000. (CO5)

MODEL PAPER
BOARD DIPLOMA EXAMINATIONS
C-23, EC-505, Data Communcation and Computer Networks
V SEMESTER
SEMESTER END EXAMINATION

TIME:3 HOURS

MAX MARKS:80

Part-A

10×3=30

Instructions: (1) Answer **all** questions.
(2) Each question carries **three** marks
(3) Answer should be brief and straight to the point and shall not exceed five simple sentences.

1. State the need for data communication networking (CO1)
2. List different network topologies. (CO1)
3. List the three types of switching techniques used in networking (CO2)
4. State the need for protocols in computer networks. (CO2)
5. State the use of repeater/ hub (CO2)
6. Define the terms Internet and Intranet. (CO3)
7. Mention the role of DNS server (CO3)
8. List the advantages of WLAN. (CO4)
9. State the fundamentals of Cyber Securitiy. (CO5)
10. List the software attacks in Cyber attacks. (CO5)

Part-B

5×10=50

Instructions: (1) Answer **all** questions.
(2) Each question carries **TEN** marks
(3) Answer should be comprehensive and the criterion for valuation is the content but not the length of the answer.

11. Draw the ISO: OSI 7 layer architecture and State the functions of each layer. (CO1)
12. Explain the frame format for Ethernet and State the different fields in it. (CO2)
13. Distinguish among cut through, store-and-forward and adaptive switch mechanisms. (CO3)
14. Explain the connectivity of systems using TCP (Three way hand shake) (CO3)
15. Explain the internal architecture of ISP. (CO3)
16. Explain the topology of wirelss LAN and its frame fromat (IEEE 802.11) (CO4)
17. Describe the feautres of Zigbee Technology and its topologies. (CO4)
18. Explain the active and passive attacks in Cyber attacks. (CO5)

EMBEDDED SYSTEMS LAB

Course Code	Course title	No of periods/week	Total no of periods	Marks for FA	Marks for SA
EC-506	EMBEDDED SYSTEMS LAB	03	45	40	60

S No	Unit Title	No. of Periods	COs Mapped
1	Familiarise with ARM CORTEX M3 evaluation board/ ARDUINO DUE Board(contains ARM cortex M3)	3	CO1
3	Familiarise with Keil uVision-5 tool/compiler ARDUINO IDE (or equivalent software)	3	CO3
4	Programming and Interfacing with ARM CORTEX M3	39	CO4
	Total	45	

Course Objectives	To get acquainted with ARM CORTEX M3 evaluation board/ ARDUINO DUE Board(contains ARM cortex M3)
	To work with Keil uVision-5 tool/compiler/ ARDUINO IDE (or equivalent software)
	Programming and Interfacing with ARM CORTEX M3

CO No	COURSE OUTCOMES	
CO1	EC-506.1	Acquainted with Keil uVision-5 tool/compiler
CO2	EC-506.2	Work with Keil uVision-5 tool/compiler
CO3	EC-506.3	Programming and Interfacing with ARM CORTEX M3

CO-PO/PSO MATRIX

CO No	PO1	PO2	PO3	PO4	PO5	PO6	PO7	PSO1	PSO2	PSO3
EC-506.1	3	3	1	1	3	3	1	3	1	1
EC-506.2	3	3	1	1	3	3	2	3	1	1

EC-506.3	3	3	1	2	3	3	2	3	2	3
EC-506.4	3	3	3	3	3	3	3	3	3	3
Average	3	3	1.5	1.75	3	3	2	3	1.75	2

3=strongly mapped
2=moderately mapped
1=slightly mapped

LEARNING OUTCOMES:

1. Conduct the following experiments on an ARM CORTEX M3 evaluation board/ ARDUINO DUE Board(contains ARM cortex M3) using evaluation version of Embedded 'C' & Keil uVision-5 tool/ ARDUINO IDE (or equivalent software).
2. Familiarise with ARM CORTEX M3 evaluation board/ ARDUINO DUE Board(contains ARM cortex M3)
3. Familiarise with Keil uVision-5 tool/ ARDUINO IDE (or equivalent software)
4. Write a C program for blinking LED/LEDs with an one second interval of time and Interface the LED/LEDs to ARM CORTEX M3 controller/ ARDUINO DUE and test it.
5. Write a C program for switch Interface with ARM based microcontroller/ ARDUINO DUE to read status of switch/switches and display the in LED/Relay/Buzzer. Interface the LED/Relay/Buzzer to ARM CORTEX M3 controller and test it.
6. Write a C program to interface a 4x4 keypad and an LCD to display the keycode on an LCD. Interface the keypad and LCD to ARM CORTEX M3 controller/ ARDUINO DUE and test it.
7. Write a C program to rotate DC motor in clockwise and anticlockwise direction with different speed using ARM based microcontroller. Interface the DC motor to ARM CORTEX M3 controller/ ARDUINO DUE and verify its working
8. Write a C program to control and run the stepper motor in half step and full step mode using ARM based microcontroller. Interface the DC motor to ARM CORTEX M3 controller/ ARDUINO DUE and verify its working.
9. Design and test a C program to display temperature (using DHT11 temperature & humidity sensor) on LCD by interfacing temperature sensor using ARM based microcontroller/ ARDUINO DUE.
10. Interface Flame sensor with ARDUINO DUE and turn on Buzzer when flame detected
11. Interface Ultrasonic sensor with ARDUINO DUE to measure the distance from the target
12. Interface RTC with ARDUINO DUE and display Date, Time on LCD display

INDUSTRIAL ELECTRONICS & AUTOMATION LAB

Course Code	Course title	No of periods/week	Total no of periods	Marks for FA	Marks for SA
EC-507	INDUSTRIAL ELECTRONICS & AUTOMATION LAB	03	45	40	60

S No	Unit Title	No. of Periods	COs Mapped
1	Power electronic devices	21	CO1
3	Transducers	9	CO3
4	PLCs	15	CO4
	Total	45	

Course Objectives	1. To familiarize with power Electronic devices, opto electronic devices, Transducers
	2. To familiarize with PLC
	3. To learn the practical importance and applications of Industrial electronics devices and PLC

CO No	COURSE OUTCOMES	
CO1	EC-507.1	Plot V-I characteristics of Power Electronic devices.
CO2	EC-507.2	Plot V-I characteristics of Transducers.
CO3	EC-507.3	Know the application and usage of PLC.

CO-PO/PSO MATRIX

CO No	PO1	PO2	PO3	PO4	PO5	PO6	PO7	PSO1	PSO2	PSO3
EC-507.1	3	3	1	1	3	3	1	3	1	1
EC-507.2	3	3	1	1	3	3	2	3	1	1
EC-507.3	3	3	1	2	3	3	2	3	2	3
Average	3	3	1.5	1.75	3	3	2	3	1.75	2

3=strongly mapped
 2=moderately mapped
 1=slightly mapped

LEARNING OUTCOMES:

I. Power electronic devices

1. Perform an experiment to obtain VI characteristics of SCR
2. Perform an experiment to obtain VI characteristics of TRIAC
3. Perform an experiment to obtain VI characteristics of DIAC
4. Perform an experiment to obtain VI characteristics of UJT
5. construct UJT relaxation oscillator circuit and observe the output waveforms on CRO
6. Construct a circuit to trigger SCR by UJT and control output Power

III. Transducers

7. Obtain the performance characteristics of LVDT by conducting an experiment
8. Obtain the performance characteristics of thermocouple by conducting an experiment

IV. Programmable Logic Controllers

9. Familiarize with PLC tutor or PSIM
10. Implement basic gates and universal gates using PLC
11. Implement XOR, XNOR gates using PLC
12. Implement a counter using PLC

-0o0-

LIFE SKILLS

Course Code	Course Title	No. of Periods/Week	Total No. of Periods	Marks for FA	Marks for SA
EC-508	Life Skills	3	45	40	60

Course Objectives: The students shall

- understand the relevance of life skills in both personal and professional lives
- practise life skills complementarily in life-management to lead a happy and successful life

Course Outcomes: The students shall

CO1: exhibit right attitude and be adaptable in adverse and diverse situations.

CO2: set appropriate goals and achieve them through proper planning, time management and self-motivation

CO3: solve diverse real-life and professional problems with critical thinking and creativity for a stress-free life.

CO4: be an ideal team player and manifest as a leader.

Course Delivery:

Text book: **“Life Skills”** – by State Board of Technical Education and Training, AP

Sl no	Unit	Teaching Hours
1	Attitude	4
2	Adaptability	4
3	Goal Setting	4
4	Motivation	4
5	Time Management	4
6	Critical thinking	4
7	Creativity	4
8	Problem Solving	5
9	Team work	4
10	Leadership	4
11	Stress Management	4
	Total	45

Course Content:

UNIT 1: Attitude *matters!*

Preparatory activity-Role play; Generating word bank; Types of attitude. Read the passage and answer the related questions, read the story and discuss issues raised; Express opinions on the given topic and fill the grid with relevant words.

UNIT 2: Adaptability... *makes life easy!*

Pair work-Study the given pictures and understand adaptability -read the anecdote and discuss, read the story and answer the questions, role play

UNIT 3: Goal Setting... *life without a goal is a rudderless boat!*

Short term goals and long term goals-SMART features, observe the pictures and answer questions-matching- read the passage and answer questions-filling the grid.

UNIT 4: Motivation... *triggers success!*

Types of motivation-difference between motivation and inspiration- matching different personalities with traits - dialogue followed by questions - writing a paragraph based on the passage.

UNIT 5: Time Management ... *the need of the hour!*

Effective Time Management- Time quadrant - Group task on management of time- Time wasters-fill in the grid, read the story and answer the questions- prioritising tasks.

UNIT 6: Critical Thinking... *Logic is the key!*

Preparatory activity-read the passage and answer the questions- differentiate between facts and assumptions- components of critical thinking- complete the sets of analogies- choose the odd one out- true or false statements- decide which of the conclusions are logical.

UNIT 7: Creativity.... *The essential YOU!!*

Definition- Pre-activity-read the anecdote and answer the questions- matching celebrities with their fields of specialisation- think of creative uses of objects- think creatively in the given situations.

UNIT 8: Problem Solving... *there is always a way out!*

Preparatory activity-read the story and answer the questions- discuss the given problem and come out with three alternative solutions- group activity to select the best solution among available alternatives- discuss the problem and plan to analyse it.

UNIT 9: Team Work... *Together we are better!*

Advantages of team work- Characteristics of a team player- Activity-Observe the pictures and classify them into two groups- team game - read the story and answer the questions- fill in the grid.

UNIT 10 : Leadership... *the making of a leader!*

Characteristics of effective leadership- styles of leadership- Activity-read the dialogue and answer the questions- identify the people in the picture and describe them- discuss leadership qualities of the given leaders- filling the grid- read the quotes and write the name of the leader.

UNIT 11: Stress Management ... *live life to the full !!*

Types of stress- Strategies for Stress Management- Activity-read the passage and answer the questions, read the situation and write a paragraph about how to manage stress.

Mapping Course Outcomes with Program Outcomes

P O	1	2	3	4	5	6	7
C O	POs 1 to 5 are applications of Engineering Principles, can't directly be mapped to Life Skills					1,2,3,4	1,2,3,4

Cos- POs Mapping :

CO	Course Outcome	CO Unit Mapped	PO mapped	Cognitive levels as per Bloom's Taxonomy R/U/Ap/An/Ev/Cr (Remembering / Understanding/ Applying/Analysing/ Evaluating/ Creating)
CO 1	To exhibit right attitude and be adaptable to adverse and diverse situations	All Lessons (1 to 11)	6,7	U/Ap/ An
CO2	To set appropriate goals and achieve them through proper planning, time management and self-motivation	3,4,5	6,7	U/Ap/An
CO3	To solve diverse real-life and professional problems with critical thinking and creativity for a stress-free life	6,7,8,11	6,7	U/Ap/An/ Ev/ Cr.
CO4	To be an ideal team player and manifest as a leader	9,10	6,7	U/Ap/An/ Ev

ASSESSMENT

C23-Common-508: Life Skills

- The assessment for C23-Common 508 is on par with all other practical subjects comprising 40 marks for Internal Assessment and 60 marks for External examination attaining the final total of 100 Marks.
- The Internal Assessment can be conducted in the form of Assignments in all the 11 Units together, taking the average for 40 marks as suggested below.
- The Assessment sheet provided after each lesson in the workbook can be evaluated as an assignment (A) for 10 marks. In addition to that, another assignment (B) can be conducted for 10 marks in each Unit, awarding total average of 10 marks for each Lesson. Finally the grand total can be averaged for 40 marks as Internal marks.
- The students can present these assignments (B) to the teacher orally and they should also write down their assignments (B) in a separate note book for practice as they are going to speak/present in the external examination and submit the same to the teacher.
- The questions for Assignment styles vary from Lesson to Lesson as different skills are assessed in each Lesson with specific parameters. We can also consider the questions of assignments given after each lesson in the workbook.
- The assignment questions can also be given based on case studies, personal experiences, observations, making inferences/ analysis/ forming opinions, solving puzzles, questions on logical thinking, reasoning, evaluating and writing reviews..etc.

Calculating Internal marks through Assignments				
Name of the student:		PIN:	Branch:	Academic Year:
S. No.	Title of the Unit / Lesson	Assignment A: 10Marks (assessment sheets after each lesson)	Assignment B: 10 Marks	Total Marks in each Unit/ Lesson (Average for 10 Marks)
1	Attitude			
2	Adaptability			
3	Goal setting			
4	Motivation			
5	Time Management			
6	Critical Thinking			
7	Creativity			
8	Problem Solving			
9	Team work			
10	Leadership			
11	Stress Management			
	Marks scored	Example: :		90
	Total Number of Assignments			11
	Internal Assessment: Average for 40 Marks	Example: $(90/11) \times 4 = 32.7$		33

End Exam Model paper: C23-Common-508 : Life Skills Lab

-----**Guidelines to
prepare the question paper of the Lab End exam for 60 marks:**

I. Define any three of the following terms of Life skills: (Oral) – 10 Marks

(From Lessons 1 to 11)

II. Recollect and narrate an incident either from your personal experience or observation where you have exhibited/ learned about any one of the following life skills. (oral) – 15 Marks.

(From Lessons 1 to 4: Attitude/ Adaptability/Motivation/Goal setting/

III. Recollect and narrate an incident either from your personal experience or observation where you have exhibited/ learned about any one of the following life skills. (oral) – 15Marks.

(From Lessons 5, 9,10,11 : Time Management, Team Work, Leadership, Stress Management)

IV. A question on problem solving skill, using creativity and critical thinking.

(A case study/a problematic situation should be provided by the examiner and the students should answer it in writing.)

Ex: Analyse the following problematic situation and write down the possible solutions and choose the best among them using your creativity and critical thinking / How do you solve the following problem?– (written) 20 Marks

(From Lessons 6,7,8: Creativity/ Critical Thinking/ Problem Solving)

Note: The questions I to III can be evaluated through Viva Voce and Q.No. IV should be answered by the students in writing. The examiner can adapt the blended mode of evaluation (oral& written) in view of the more number of students and time constraint.

ADVANCED COMMUNICATIONS LAB

Course Code	Course title	No of periods/week	Total no of periods	Marks for FA	Marks for SA
EC-509	ADVANCED COMMUNICATIONS LAB	03	45	40	60

S No	Chapter/ Unit Title	No. of Periods	COs Mapped
1.	Microwave Communications	12	CO1
2.	Antennas	9	CO2
3.	Fiber optic Communication	9	CO3
4.	Data Communication and Computer Networks	15	CO4
	Total	45	

Course Objectives	1. To familiarise with microwave Devices, Antennas and o handle the microwave bench
	2. To handle the Optical bench to perform various measurements.
	3. To learn the practical importance of microwave devices and antennas, Networking and fiber optic communication methods.

CO No		COURSE OUTCOMES
CO1	EC-509.1	Understand various microwave components and devices.
CO2	EC-509.2	Interpret the radiation characteristics of various antennas
CO3	EC-509.3	Understand the light propagation through optical fiber
CO4	EC-509.4	Perform experiments on Computer Networking and handle advanced communication gadgets

CO-PO/PSO MATRIX

CO No	PO1	PO2	PO3	PO4	PO5	PO6	PO7	PSO1	PSO2	PSO3
EC-509.1	3	1		3		1	2	3	1	1
EC-509.2	3	1	2	3	1	2	2	3	1	2
EC-509.3	3			3		1	2	3		2
EC-509.4	3	1	2	3	3	3	3	3	1	3
Average	3	1	2	3	2	3	2.25	3	1	2

3=strongly mapped
 2=moderately mapped
 1=slightly mapped

LEARNING OUTCOMES:

1.0 Microwave Communications

1. Conduct an experiment to plot the Characteristics of Reflex Klystron
2. Conduct an experiment to plot the Characteristics of Gunn diode
3. Conduct an experiment to measure VSWR
4. Conduct an experiment to determine the frequency in a rectangular wave guide

2.0 Antennas

1. Plot the radiation pattern of simple dipole antenna
2. Plot the radiation pattern of simple folded dipole antenna
3. Study the radiation pattern of parabolic antenna

3.0 Fiber Optics

1. Set up fiber optic analogue link and demonstrate analog signal transmission
2. Set up a fiber optic digital link and demonstrate digital data transmission
3. Set up fiber optic voice link and demonstrate voice communication

4.0 Computer Networking

1. Identify and note down the specifications of various networking devices & Cables, Jacks, Connectors, tools etc used in local area networks.
2. Prepare the UTP cable for cross and direct connections using crimping tool
3. Setup LAN and a) transfer files between systems in LAN b) share the printer in a network
4. Test the network using ipconfig, ping / tracert and netstat utilities and debug the network issues
5. Install and Configure wireless NIC and transfer files between systems in LAN and wireless LAN

-0o0-

PROJECT WORK

Course Code	Course title	No of periods/week	Total no of periods	Marks for FA	Marks for SA
EC-510	PROJECT WORK	03	45	40	60

LEARNING OUTCOMES:

1.0 Project work

- 1.1 Identify different works to be carried out in the Project
- 1.2 Collect data relevant to the project work
- 1.3 Carryout need survey
- 1.4 Select the most efficient method from the available choices based on preliminary investigation
- 1.5 Design the required elements of the project work as per standard practices
- 1.6 Prepare the working modules / equipment required for the project work
- 1.7 Estimate the cost of project, technological need, computer skills, materials and other equipment
- 1.8 Prepare the plan and schedule of starting time and sequence of operations to be carried out at various stages of the project work in detail
- 1.9 Prepare critical activities at various stages of the project work
- 1.10 Test various conditions with different electrical input parameter if required
- 1.11 Implement project work and record the results.
- 1.12 Preparation of project report.

-0o0-

VI Semester

**DIPLOMA IN ELECTRONICS & COMMUNICATION ENGINEERING
SCHEME OF INSTRUCTIONS AND EXAMINATIONS
C-23-VI Semester**

EC-601 INDUSTRIAL TRAINING

Sl.No.	Subject	Duration	Scheme of evaluation		
			Item	Nature	Max. Marks
1	Industrial Training	6 months	1.First Assessment at Industry (After 12 Weeks)	Assessment of learning outcomes by both the faculty and training mentor of the industry	120
			2.Second Assessment at the Industry (After 20 weeks))	Assessment of learning outcomes by both the faculty and training mentor of the industry	120
			Final Summative assessment at institution level	Training Report	20
				Demonstration of any one of the skills listed in learning outcomes	30
				Viva Voce	10
TOTAL MARKS					300

The Industrial Training shall carry maximum 300 marks. Students can be trained in Industry. Pass mark is 50% in first and second assessment put together and also 50% in final summative assessment at the institution level.

INDUSTRIAL TRAINING

Course Code	Course Title	Duration	Marks for Formative Assessment	Marks for Summative Assessment
EC-601	Industrial Training	24 weeks	240	60

Time schedule

S.NO	Code	TOPICS	Duration
1	EC-601	<ul style="list-style-type: none"> • Practical training in Industry • Training Report Preparation Report Preparation: Title Page, Certificate, Acknowledgements, Abstract, Contents (introduction of Industry, Plant Layout, Organization Chart, List of Major Equipments, List of Processes: Skills Acquired, Conclusions, References	Six Months

Course Objectives and Course Outcomes

Upon completion of the course the student shall be able to									
Course Objectives	1.Expose to real time working environment 2. Enhance knowledge and skill already learnt in the institution. 3. Acquire the required skills of troubleshooting of various electronic devices, assembling, servicing, and supervising in the engineering fields. 4. Install the good qualities of integrity, responsibility and self confidence.								
COURSE OUT COMES	<table border="1" style="width: 100%; border-collapse: collapse;"> <tr> <td style="width: 10%; text-align: center;">CO1</td> <td>Apply theory to practical work situations</td> </tr> <tr> <td style="text-align: center;">CO2</td> <td>Cultivate sense of responsibility and good work habits</td> </tr> <tr> <td style="text-align: center;">CO3</td> <td>Exhibit the strength, teamwork spirit and self-confidence</td> </tr> <tr> <td style="text-align: center;">CO4</td> <td>Write report in technical projects</td> </tr> </table>	CO1	Apply theory to practical work situations	CO2	Cultivate sense of responsibility and good work habits	CO3	Exhibit the strength, teamwork spirit and self-confidence	CO4	Write report in technical projects
CO1	Apply theory to practical work situations								
CO2	Cultivate sense of responsibility and good work habits								
CO3	Exhibit the strength, teamwork spirit and self-confidence								
CO4	Write report in technical projects								

PO-CO Mapping

	PO1	PO2	PO3	PO4	PO5	PO6	PO7	PSO1	PSO2	PSO3
CO1	2	2		2	2		1	3	2	2
CO2						3		3		2
CO3						3		3		2
CO4						3		3		2

3: High, 2: Moderate, 1: Low

Learning Outcomes

The student shall be able to display the following skill sets

- 1) Use appropriate tools/instruments for a given purpose and measure the values using instruments
- 2) Assembling and Disassembling of circuits
- 3) Coding and debugging

- 4) Troubleshoot/ Rectification of the problem
- 5) Design and Fabrication of the circuit
- 6) Soft skills and Reporting

Scheme of evaluation

Sl. No.	Course	Duration	Scheme of evaluation		
			Item	Nature	Max. Marks
1	Industrial Training	6 months	1.First Assessment at Industry (After 12 Weeks)	Assessment of Learning outcomes by both the faculty and training Mentor of the industry	120
			2.Second Assessment at the Industry (After 22 weeks)	Assessment of Learning outcomes by both the faculty and training Mentor of the industry	120
			Final Summative assessment at institution level	Training Report	20
				Demonstration of any one of the skills listed in learning outcomes	30
				Viva Voce	10
TOTAL MARKS					300

Weightage of marks for Assessment of Skill sets during first and second assessment.

Skill Set Sl.No	SKILL SET	Max Marks Allotted For each parameter
1	Use appropriate tools/instruments for a given purpose and measure the values using instruments	15
2	Assembling and Disassembling of circuits	20
3	Programming/Coding/debugging	15
4	Troubleshoot/ Rectification of the problem	20
5	Design and Fabrication of the circuit	25

6	<i>Softskills and Reporting Skills</i>	25
	<i>Total</i>	120

During assessment the performance of the students shall be assessed in those skills in which the student has been trained and be awarded the marks as per the weightage assigned as above. In case the student has undergone training in a few skill sets then the total marks obtained shall be raised to 120 marks for the given assessment i.e. either assessment 1 or 2. However the performance of the student shall be assessed at the most skill sets listed above but not less than three skill sets.

Illustration

If the student has undergone training in only 4 skill sets (namely serial number 1, 3, 4, 5 of above skill sets) and marks awarded during assessment is 50 out of 80 marks, then the marks of 50 shall be enhanced to 120 proportionately as $(50/80)*120=75$.

GUIDELINES FOR INDUSTRIAL TRAINING

1. Duration of the training: 6 months.
2. Eligibility: The As per SBTET norms
3. Training Area: Students may be trained in the fields
Fabrication/Foundry/Manufacturing/Service/Drafting/Maintenance etc.
4. The candidate shall put a minimum of 90% attendance during Industrial Training.
5. If the student fails to secure 90% attendance during industrial training, the student shall reappear for 6 months industrial training.
6. Formative assessment at industry level shall be carried out by the Mentor from of the industry, where the student is undergoing training and the faculty in charge (Guide) from the concerned section in the institution.
7. The Industrial training shall carry 300 marks and pass marks is 50% in assessments at industry (first and second assessment), 50% in final summative assessment at institution level and put together i.e. 150 marks out of 300 marks.
8. If the student fails to secure 50% marks in final summative assessment at institution level, the student should reappear for final summative assessment in the subsequent board examination.
9. Final Summative assessment at institution level is done by a committee including Head of the section (**of concerned discipline ONLY**), External examiner and Faculty members who assessed the students during Industrial Training as members.

Guidelines and responsibilities of the faculty members who are assessing the students performance during industrial training:

- Shall guide the students in all aspects regarding training.
- Shall create awareness regarding safety measures to be followed in the industry during the training period, and shall check it scrupulously.
- Shall check the logbook of the students during the time of their visit for the assessment.
- Shall monitor progress at regular intervals and make appropriate suggestions for improvement.
- Shall visit the industry and make first and second assessments as per stipulated schedules.
- Shall assess the skill sets acquired by the students during their assessment.

- Shall award the marks for each skill set as per the marks allotted for that skill set during 1st and 2nd assessments
- Shall voluntarily supplement students learning through appropriate materials like photographs, articles, videos etc.
- Shall act as co-examiner along with other examiners in the final assessment at institution.
- Shall act as liaison between the student and mentor.
- Shall maintain a diary indicating his observation with respect to the progress of students learning in all three domains (Cognitive, Psychomotor and Affective).

Guidelines to the Training Mentor in the industry:

- Shall train the students in all the skill sets as far as possible.
- Shall assess and award the marks in both the assessments along with the faculty member.
- Shall check and approve the log books of the students.
- Shall approve the attendance of each student at the end of the training period.
- Shall report to the guide about student's progress, personality development or any misbehavior as the case may be.
- ✓ **Every Teacher (including HoD if not holding any FAC) shall be assigned a batch of students of 10 to 15 for industrial training irrespective of student's placements for training.**

Rubrics for assessment:

**Department of Technical Education
Name of the institution
Industrial training assessment**

PIN:

Name of the student:

<i>Skill Set Sl.No</i>	<i>SKILL SET</i>	Max Marks Allotted For each parameter	Precisely complete s the task	Completes the task, mistakes are absent, but not Precise	Completes the task, Mistakes are a few	Makes attempt, Mistakes are many
1	<i>Use appropriate tools/instruments for a given purpose and measure the values using instruments (15)</i> <i>(i) Identification of tools and instruments</i> <i>(ii) Testing of components and devices</i> <i>(iii) Measuring the parameter</i>	5 5 5	5 5 5	3 3 3	2 2 2	1 1 1
2	<i>Assembling and Disassembling the equipment with proper tool (20)</i> <i>(i) Disassembling</i>	10	10	7	6	3

	<i>(ii) Assembling</i>	10	10	7	6	3
3	Programming/Coding/Debugging (15)					
	<i>(i) Programming/Coding</i>	10	10	7	6	3
	<i>(ii) Debugging</i>	5	5	3	2	1
4	Troubleshooting/Rectification of the problem.(20)					
	<i>(i) Fault-Finding</i>	10	10	7	6	3
	<i>(ii)Removal and Replacement of spare parts</i>	5	5	3	2	1
	<i>(iii) Testing the working condition.</i>	5	5	3	3	2
5	Design and Fabrication of the Circuits(25)					
	<i>(i) Designing of circuit.</i>	15	15	10	9	6
	<i>(ii) Fabrication of Circuits</i>	10	10	7	6	3
6	Soft skills and Reporting skills(25)					
	<i>(i)Communication Skills (oral/writing skills)</i>	5	5	4	3	2
	<i>(ii) Human relations.</i>	5	5	3	3	2
	<i>(iii) Supervisory abilities.</i>	5	5	3	3	2
	<i>(iv) Reporting technical issues</i>	5	5	4	3	2
	<i>(v)Maintenance of records in the industry.</i>	5	5	3	3	2
	Total Marks	120	120	80	67	38

*Mistakes are with reference to Technique, Procedure & precautions, while precision refers to technique, procedure, precautions, time & result

(Marks awarded in words:)

Signature of the Training In-charge (Mentor)
Name
Designation

Signature of the faculty incharge (Guide)
Name
Designation

-0o0-